

BEFORE ADDING TENSION USING EXTENDED TAKE-UP FRAMES

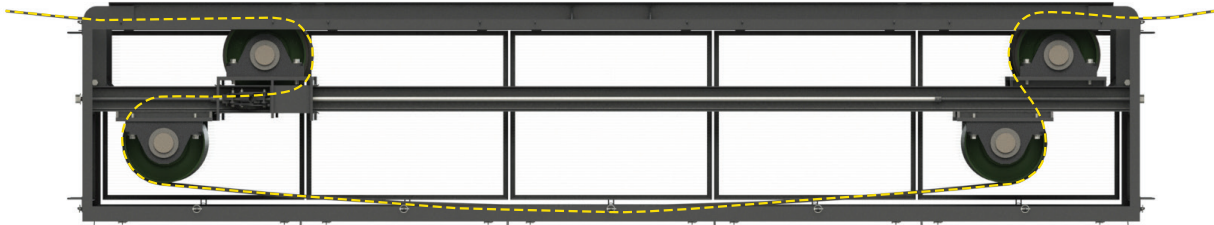

AFTER ADDING TENSION USING EXTENDED TAKE-UP FRAMES

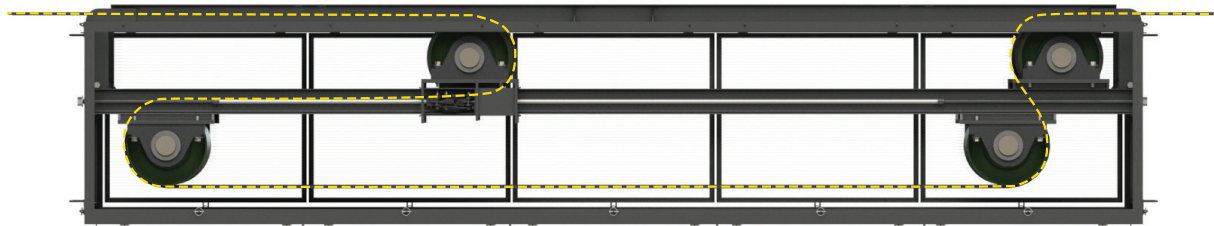

The Extended Take-Up frames provide 120" of manual conveyor belt take up. When paired with the PPI Stretch Rite program, the extended take-ups allow the use of manual take up frames on long conveyors that have historically required the use of more complicated automatic take-up systems. The extended take-ups can also be used on conveyors that have automatic take-up systems but require additional belt storage. The extended take-up frames are sold as a complete assembly that includes the pulleys. Each belt width has extended take-up frames available in two different maximum belt tension capacities.

FEATURES AND BENEFITS

- Lower cost than gravity or hydraulic take-up systems
- Less complicated than gravity or hydraulic take-up systems
- Less space required than gravity take-up systems
- 120" of pulley travel provides sufficient belt take up even for conveyors in excess of 200' long
- The mounting holes match up with standard return idler spacing for easy installation on existing conveyors
- The optional patent pending rapid travel ratchet mechanism allows for quick pulley travel while the belt tension is relatively low and precise position control when the tension is higher

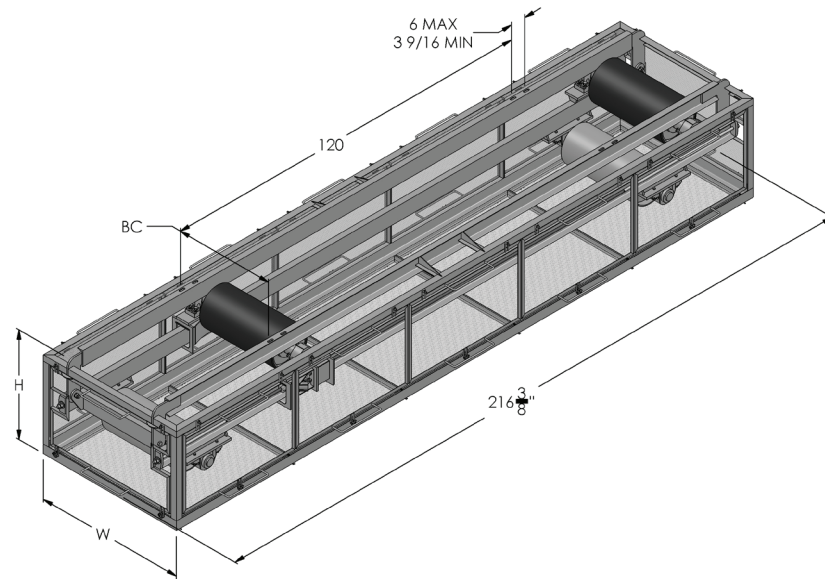

DIMENSIONS AND LOAD RATINGS

FRAME	OVERALL DIMENSIONS (INCLUDING GUARDS)		BOLT CENTERS (BC)	MAX BELT TENSION (LB)	PULLEY SIZE (DIA X FW)	WEIGHT (LB)
	H	W				
24 Low	35.5	56.625	33	4400	12 x 26	2740
24 Mid	44.5	56.625	33	7000	16 x 26	3670
30 Low	44.5	62.625	39	8300	16 x 32	4015
30 Mid	49.5	62.625	39	13000	20 x 32	5470
36 Low	44.5	68.625	45	10000	16 x 38	4530
36 Mid	49.5	68.625	45	16000	20 x 38	6885
42 Low	44.5	74.625	51	12000	16 x 44	5410
42 Mid	49.5	74.625	51	19000	20 x 44	7695
48 Low	44.5	80.625	57	14000	16 x 51	6995
48 Mid	49.5	80.625	57	22000	20 x 51	8480



www.ppi-global.com | sales@ppi-global.com

Product shown are for illustrative purposes only and may display optional accessories or components. Please contact your sales representative for more information on product specifications. PPI respectively reserves the right to make changes in engineering, design and specifications; add improvements; or discontinue manufacturing at any time without notice obligation. PPI and its respective logos are trademarks of Precision, Inc. in the US and or other countries.