

# SD 3100 BEARINGS – LABYRINTH SEAL

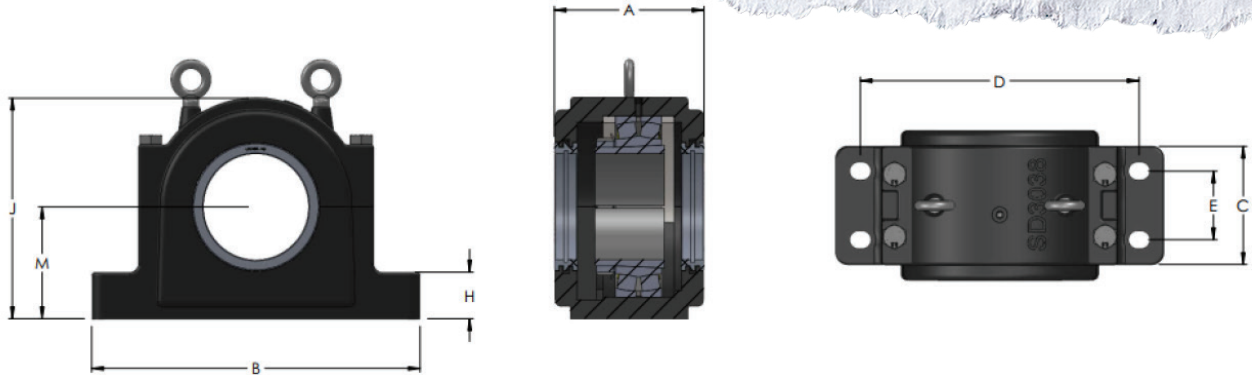

| Housing | Shaft Dia | B    | C   | H   | M   | A   | J   | D    | E   |
|---------|-----------|------|-----|-----|-----|-----|-----|------|-----|
| SD 3134 | 150       | 510  | 180 | 70  | 170 | 232 | 335 | 430  | 100 |
| SD 3136 | 160       | 530  | 190 | 75  | 180 | 242 | 355 | 450  | 110 |
| SD 3138 | 170       | 560  | 210 | 80  | 190 | 261 | 375 | 480  | 120 |
| SD 3140 | 180       | 610  | 230 | 85  | 210 | 281 | 410 | 510  | 130 |
| SD 3144 | 200       | 640  | 240 | 90  | 220 | 291 | 435 | 540  | 140 |
| SD 3148 | 220       | 700  | 260 | 95  | 240 | 312 | 475 | 600  | 150 |
| SD 3152 | 240       | 770  | 280 | 100 | 260 | 322 | 515 | 650  | 160 |
| SD 3156 | 260       | 790  | 280 | 105 | 280 | 322 | 550 | 670  | 160 |
| SD 3160 | 280       | 830  | 310 | 110 | 300 | 353 | 590 | 710  | 190 |
| SD 3164 | 300       | 880  | 330 | 115 | 320 | 373 | 630 | 750  | 200 |
| SD 3168 | 320       | 950  | 360 | 120 | 340 | 402 | 675 | 810  | 220 |
| SD 3172 | 340       | 1000 | 360 | 120 | 350 | 402 | 695 | 840  | 220 |
| SD 3176 | 360       | 1040 | 360 | 120 | 360 | 402 | 715 | 870  | 220 |
| SD 3180 | 380       | 1120 | 390 | 125 | 380 | 433 | 775 | 950  | 240 |
| SD 3184 | 400       | 1170 | 420 | 130 | 410 | 463 | 810 | 1000 | 260 |
| SD 3188 | 410       | 1220 | 430 | 135 | 420 | 463 | 835 | 1030 | 260 |
| SD 3192 | 430       | 1280 | 440 | 145 | 440 | 473 | 880 | 1070 | 260 |
| SD 3196 | 450       | 1330 | 440 | 155 | 460 | 473 | 920 | 1110 | 260 |

## FEATURES AND BENEFITS

- Bearing housings are made from spherical graphite iron (Grade 65-45-12 ductile iron) which is stronger and more durable than cast iron.
- Housings come complete with housing, fixing rings, seals and end cap to allow for open and closed shaft position and fixed or floating bearing set ups.
- Housings come standard with Labyrinth seals; Taconite seals optional.
- Housings fit all major international brand bearings.
- Bearings and adapter sleeves ordered separately; PPI offers all major brands.

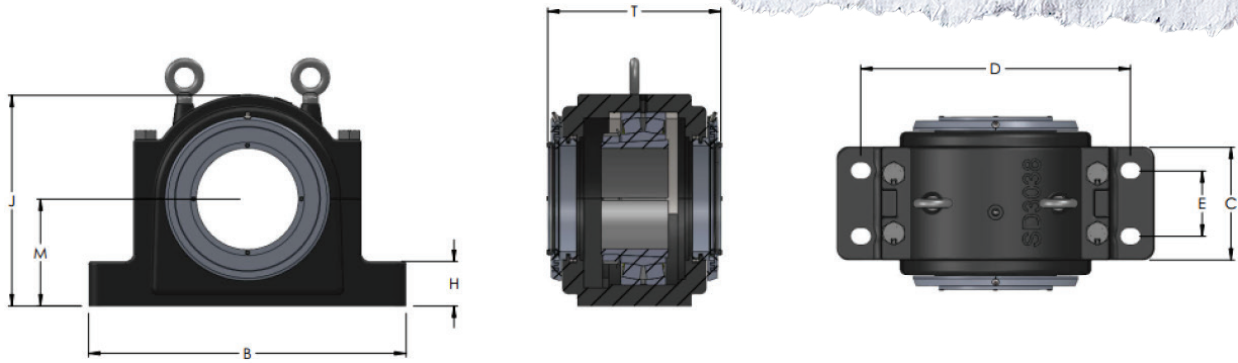

| Housing | Shaft Dia | B    | C   | H   | M   | T   | J   | D    | E   |
|---------|-----------|------|-----|-----|-----|-----|-----|------|-----|
| SD 3134 | 150       | 510  | 180 | 70  | 170 | 279 | 335 | 430  | 100 |
| SD 3136 | 160       | 530  | 190 | 75  | 180 | 289 | 355 | 450  | 110 |
| SD 3138 | 170       | 560  | 210 | 80  | 190 | 308 | 375 | 480  | 120 |
| SD 3140 | 180       | 610  | 230 | 85  | 210 | 329 | 410 | 510  | 130 |
| SD 3144 | 200       | 640  | 240 | 90  | 220 | 340 | 435 | 540  | 140 |
| SD 3148 | 220       | 700  | 260 | 95  | 240 | 360 | 475 | 600  | 150 |
| SD 3152 | 240       | 770  | 280 | 100 | 260 | 370 | 515 | 650  | 160 |
| SD 3156 | 260       | 790  | 280 | 105 | 280 | 370 | 550 | 670  | 160 |
| SD 3160 | 280       | 830  | 310 | 110 | 300 | 401 | 590 | 710  | 190 |
| SD 3164 | 300       | 880  | 330 | 115 | 320 | 421 | 630 | 750  | 200 |
| SD 3168 | 320       | 950  | 360 | 120 | 340 | 450 | 675 | 810  | 220 |
| SD 3172 | 340       | 1000 | 360 | 120 | 350 | 450 | 695 | 840  | 220 |
| SD 3176 | 360       | 1040 | 360 | 120 | 360 | 450 | 715 | 870  | 220 |
| SD 3180 | 380       | 1120 | 390 | 125 | 380 | 481 | 775 | 950  | 240 |
| SD 3184 | 400       | 1170 | 420 | 130 | 410 | 511 | 810 | 1000 | 260 |
| SD 3188 | 410       | 1220 | 430 | 135 | 420 | 513 | 835 | 1030 | 260 |
| SD 3192 | 430       | 1280 | 440 | 145 | 440 | 523 | 880 | 1070 | 260 |
| SD 3196 | 450       | 1330 | 440 | 155 | 460 | 523 | 920 | 1110 | 260 |

## FEATURES AND BENEFITS

- Bearing housings are made from spherical graphite iron (Grade 65-45-12 ductile iron) which is stronger and more durable than cast iron.
- Housings come complete with housing, fixing rings, seals and end cap to allow for open and closed shaft position and fixed or floating bearing set ups.
- Housings come standard with Labyrinth seals; Taconite seals optional.
- Housings fit all major international brand bearings.
- Bearings and adapter sleeves ordered separately; PPI offers all major brands.

[WWW.PPI-GLOBAL.COM](http://WWW.PPI-GLOBAL.COM) | [SALES@PPI-GLOBAL.COM](mailto:SALES@PPI-GLOBAL.COM)

Product shown are for illustrative purposes only and may display optional accessories or components. Please contact your sales representative for more information on product specifications. PPI respectively reserves the right to make changes in engineering, design and specifications; add improvements; or discontinue manufacturing at any time without notice obligation. PPI and its respective logos are trademarks of Precision, Inc. in the US and or other countries.