

# SD 3000 BEARINGS – LABYRINTH SEAL

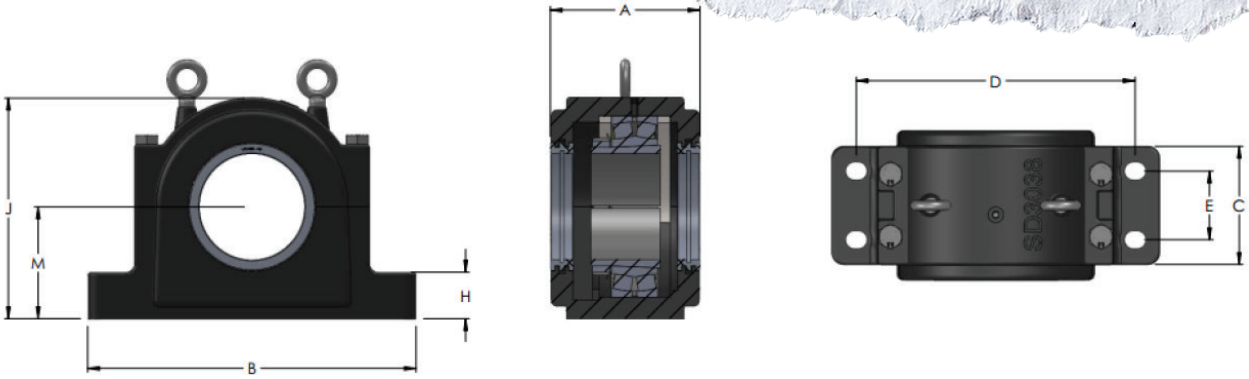

Housing	Shaft Dia	B	C	H	M	A	J	D	E
SD 3036	160	510	180	70	170	232	335	430	100
SD 3038	170	530	190	75	180	242	355	450	110
SD 3040	180	560	210	80	190	261	375	480	120
SD 3044	200	610	230	85	210	281	410	510	130
SD 3048	220	640	240	90	220	292	435	540	140
SD 3052	240	700	260	95	240	312	475	600	150
SD 3056	260	770	280	100	260	322	515	650	160
SD 3060	280	790	280	105	280	323	550	670	160
SD 3064	300	830	310	110	300	353	590	710	190
SD 3068	320	880	330	115	320	373	630	750	200
SD 3072	340	880	330	115	320	373	630	750	200
SD 3076	360	950	360	120	340	402	675	810	220
SD 3080	380	1000	360	120	350	403	695	840	220
SD 3084	400	1040	360	120	360	403	715	870	220
SD 3088	410	1120	390	125	380	433	775	950	240
SD 3092	430	1170	420	130	410	463	810	1000	260
SD 3096	450	1170	420	130	410	463	810	1000	260

## FEATURES AND BENEFITS

- Bearing housings are made from spherical graphite iron (Grade 65-45-12 ductile iron) which is stronger and more durable than cast iron.
- Housings come complete with housing, fixing rings, seals and end cap to allow for open and closed shaft position and fixed or floating bearing set ups.
- Housings come standard with Labyrinth seals; Taconite seals optional.
- Housings fit all major international brand bearings.
- Bearings and adapter sleeves ordered separately; PPI offers all major brands.

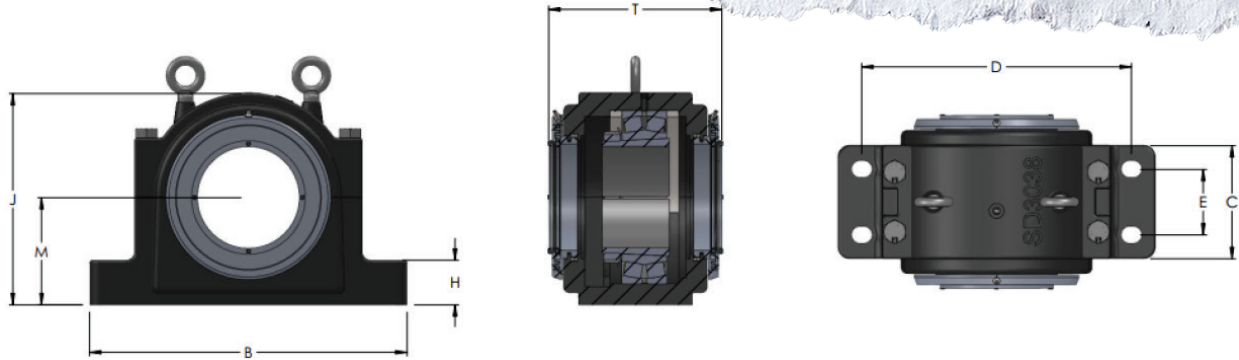

Housing	Shaft Dia	B	C	H	M	T	J	D	E
SD 3036	160	510	180	70	170	279	335	430	100
SD 3038	170	530	190	75	180	289	355	450	110
SD 3040	180	560	210	80	190	309	375	480	120
SD 3044	200	610	230	85	210	329	410	510	130
SD 3048	220	640	240	90	220	340	435	540	140
SD 3052	240	700	260	95	240	360	475	600	150
SD 3056	260	770	280	100	260	370	515	650	160
SD 3060	280	790	280	105	280	370	550	670	160
SD 3064	300	830	310	110	300	401	590	710	190
SD 3068	320	880	330	115	320	421	630	750	200
SD 3072	340	880	330	115	320	421	630	750	200
SD 3076	360	950	360	120	340	450	675	810	220
SD 3080	380	1000	360	120	350	451	695	840	220
SD 3084	400	1040	360	120	360	451	715	870	220
SD 3088	410	1120	390	125	380	483	775	950	240
SD 3092	430	1170	420	130	410	513	810	1000	260
SD 3096	450	1170	420	130	410	513	810	1000	260

## FEATURES AND BENEFITS

- Bearing housings are made from spherical graphite iron (Grade 65-45-12 ductile iron) which is stronger and more durable than cast iron.
- Housings come complete with housing, fixing rings, seals and end cap to allow for open and closed shaft position and fixed or floating bearing set ups.
- Housings come standard with Labyrinth seals; Taconite seals optional.
- Housings fit all major international brand bearings.
- Bearings and adapter sleeves ordered separately; PPI offers all major brands.

[WWW.PPI-GLOBAL.COM](http://WWW.PPI-GLOBAL.COM) | [SALES@PPI-GLOBAL.COM](mailto:SALES@PPI-GLOBAL.COM)

Product shown are for illustrative purposes only and may display optional accessories or components. Please contact your sales representative for more information on product specifications. PPI respectively reserves the right to make changes in engineering, design and specifications; add improvements; or discontinue manufacturing at any time without notice obligation. PPI and its respective logos are trademarks of Precision, Inc. in the US and or other countries.