

PCP frames are designed to handle push or pull applications. PCP frames can be used in passive systems where the cylinder is used to apply the tension and the screw is used to lock the bearing into position. They can also be used for active systems where there is no screw and the cylinder is used to provide tension. However, the setups are different and will be explained in this guide along with instructions to convert the frame. Page 1 will cover general cylinder requirements, page 2 is the setup of a passive system, page 3 will cover the setup of an active system, and pages 4-7 will identify the cylinders that will fit our frames.

While PPI can help you with conversion, the customer is better served by contacting their local hydraulics dealer/distributor for hydraulics and controls.

PCP frames are designed for Rod End (or Head End) Rectangular Flange Mount, Series 2HD, Heavy Duty Hydraulic Cylinders NFPA Style # MF1. Please note, KK2 threads are standard.

Cylinders for PCP Take-Up Frames are to have lip seals. The reason for this is that standard piston seals will leak. While any seal will leak, lip seals will hold pressure longer.

Cylinders for PCP Take-Up Frames are to have SAE ports. NPT ports are not rated for pressures used in PCP frames.

The cylinder should be plumbed for double action. This decreases the size of the reservoir necessary and allows the user to retract the rod under power.

While active systems can be set up for push or pull, passive systems can only be set up for the cylinder to push while the screw pulls.

The two charts to the right show the rating and size of the cylinder for each frame. The top chart is for pull, while the bottom chart is for push. Please note, for pull applications, a smaller rod size is desirable as it yields the most effective area. For a push application, a larger rod size is necessary for column strength.

The first step is to determine whether your application will be push or pull and use the appropriate chart to determine the cylinder size and rating.

For example, a frame size of 200 will accommodate a 1-15/16" bore wide slot bearing, 203 will handle a 2-3/16" bore bearing, etc.

The standard PPI PCP frame is symmetrical on both ends. This allows the user to bolt the cylinder and/or screw to either end. It also allows the user to remove the entire top of the frame.

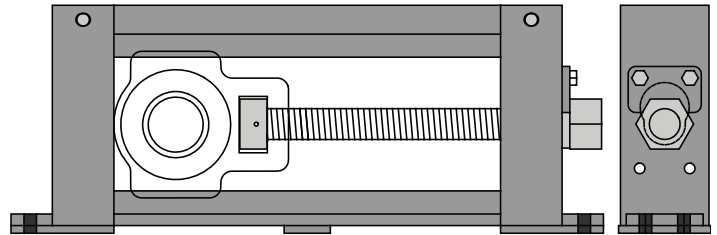

Frame Size	Cylinder Bore	Rating (pounds)	Pull - Hydraulic PCP			Pressure (PSI)
			Rod	Area	Cylinder #	
200	1 1/2	3,000	5/8	1.46	1506	2,055
203	1 1/2	4,000	5/8	1.46	1506	2,740
208	2	5,000	1	2.356	2010	2,122
300	2	6,000	1	2.356	2010	2,547
308	2 1/2	9,000	1	4.123	2510	2,183
400	3 1/4	12,000	1 3/8	6.811	3213	1,762
408	3 1/4	15,000	1 3/8	6.811	3213	2,202
500	3 1/4	18,000	1 3/8	6.811	3213	2,643

Frame Size	Cylinder Bore	Rating (pounds)	Push - Hydraulic PCP			Pressure (PSI)
			Rod	Area	Cylinder #	
200	1 1/2	3,000	1	1.767	1510	1,698
203	1 1/2	4,000	1	1.767	1510	2,264
208	2	5,000	1 3/8	3.142	2013	1,591
300	2	6,000	1 3/8	3.142	2013	1,910
308	2 1/2	9,000	1 3/8	4.909	2517	1,833
400	3 1/4	12,000	1 3/4	8.296	3217	1,446
408	3 1/4	15,000	1 3/4	8.296	3220	1,808
500	3 1/4	18,000	1 3/4	8.296	3220	2,170

PCP Active Setup

To set-up an active PCP, the first step is to remove the keeper plate from the end. Then slide the screw up the keyhole slot and out of the frame. The hydraulic cylinder will replace it.

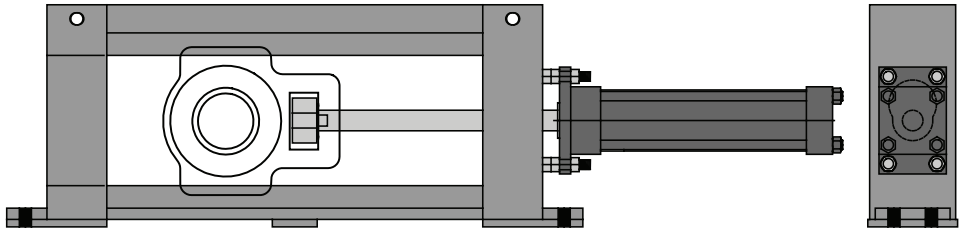

The hydraulic cylinder is mounted to the frame by four bolts. These bolts are:

- 3/8" x 2" UNF thread for 1-1/2" bore cylinders
- 1/2" x 2-1/2" UNF thread for 2" or 2-1/2" bore cylinders
- 5/8" x 3" UNF thread for 3-1/4" bore cylinders

Each bolt is to have three nuts. The first nut locks the bolt to the frame. The second and third nut lock the flange of the cylinder between them. This allows the user to fine tune the alignment of the cylinder to the frame.

At one end of the frame, insert a bolt into each of the four bolt holes in the end stand and thread on a nut. The nut should be snug, but not locked. Next, snug up a second nut to the first for each of the four bolts. Mount the cylinder over the four bolts and snug up the final nut onto the bolts.

The additional item that is necessary is the nut to fit into the bearing housing. The dimensions and materials are given in the chart to the right. It is a piece of round shafting which is drilled and tapped for the cylinder rod. Two flats are machined to facilitate turning the nut onto the threads.

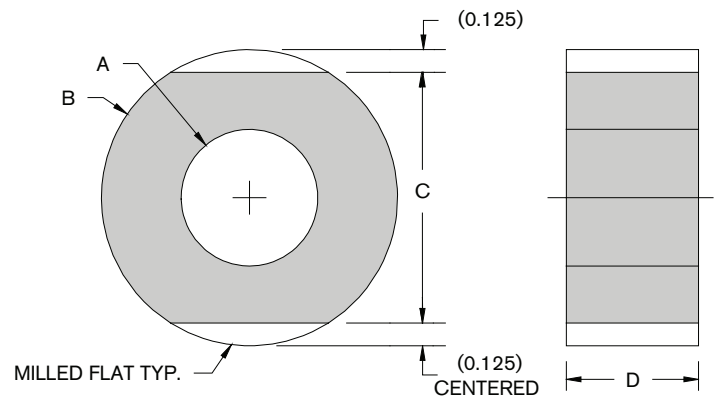
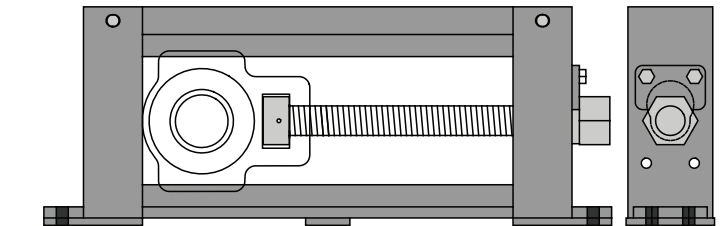

Remove the cap of the frame. Set the wide slot bearing onto the lower rail and insert the nut into the housing. With the cylinder retracted, thread the nut onto the rod.

Check the cylinder to make sure that it is centered in the frame, and that the housing is free to travel.

Using the pump, slowly extend the cylinder to its maximum extension. If the housing starts to bind or lifts off of the rails, adjust the nuts holding the cylinder to keep the cylinder in line with the travel of the housing. Once this is done, tighten the four bolts and double check the alignment.

The bearing and nut can be removed to facilitate installation of the assembly onsite. But the cylinder should be left locked into position once it has been aligned.

PCP	Cylinder #	Part #	A	B	C	D	Raw Material	Wt.
200	1506	57780	7/16"-20 UNF	1 5/8	1 3/8	0.725	1 5/8" 1045	0.4
	1510	57781	3/4"-16 UNF					0.4
203	1506	57782	7/16"-20 UNF	1 11/16	1 7/16	15/16	1 11/16" 1045	0.6
	1510	57783	3/4"-16 UNF					0.5
208	2010	57784	3/4"-16 UNF	1 7/8	1 5/8	1 1/8	1 7/8" 1045	0.8
	2013	57785	1"-14 UNF					0.7
300	2010	57786	3/4"-16 UNF	2 3/8	2 1/8	1 3/16	2 3/8" 1045	1.3
	2013	57787	1"-14 UNF					1.2
308	2510	57788	3/4"-16 UNF	2 3/4	2 1/2	1 9/16	2 3/4" 1045	2.5
	2513	57789	1"-14 UNF					2.4
400 408	3213	57790	1"-14 UNF	3 1/8	2 7/8	2	3 1/8" 1045	4
	3217	57791	1 1/4"-12 UNF					3.8
500	3213	57792	1"-14 UNF	3 1/2	3 1/4	2 1/4	3 1/2" 1045	5.8
	3217	57793	1 1/4"-12 UNF					5.5

PCP Passive Setup

In a passive setup, the screw is used to lock the housing into position. Therefore the PCP nut that holds the housing will need to have the back shoulder machined off, as shown in the diagram and chart on the bottom right.

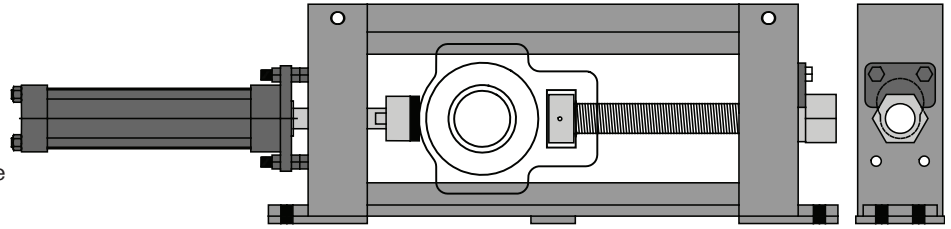

This modification will allow the screw to only pull while the hydraulic cylinder mounted on the opposite end will push. Therefore, a push nut is needed to mount on the end of the hydraulic cylinder. The push nut is drilled and tapped to fit onto the cylinder. A relief is also machined to fit over the grease fitting in the bearing. It is recommended that rubber is affixed to the end of the push nut to keep damage from occurring to the housing during the pushing operation.

The hydraulic cylinder is mounted to the frame by four bolts. These bolts are:

- 3/8" x 2" UNF thread for 1-1/2" bore cylinders
- 1/2" x 2-1/2" UNF thread for 2 or 2-1/2" bore cylinders
- 5/8" x 3" UNF thread for 3-1/4" bore cylinders

Each bolt is to have three nuts. The first nut locks the bolt to the frame. The second and third nut lock the flange of the cylinder between them. This allows the user to fine tune the alignment of the cylinder to the frame.

On one end of the frame, insert a bolt into each of the four bolt holes in the end stand and thread on a nut. The nut should be snug, but not locked. Next, snug up a second nut to the first for each of the four bolts. Mount the cylinder over the four bolts and snug up the final nut onto the bolts.

Check the cylinder to see that it is centrally mounted onto the frame. Extend the cylinder while measuring the distance between the rod and the bottom rail. If it is not the same for the full extension of the rod, adjust the four bolts until it is close to being the same.

Retract the cylinder and mount the frame, wide-slot bearing and nut as in standard PCP.

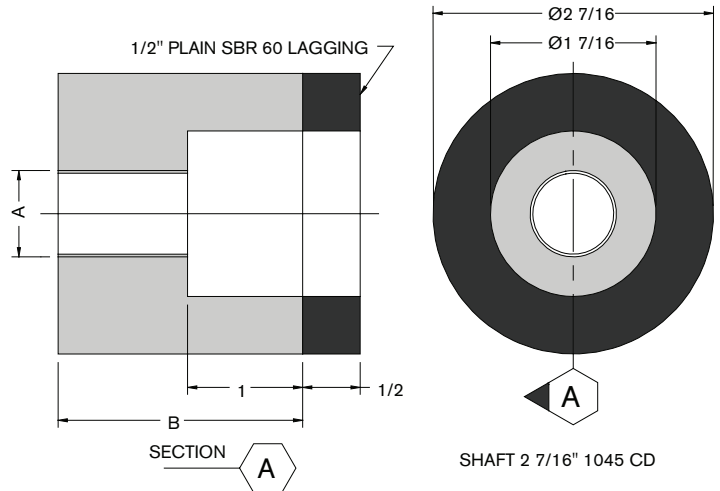

Cylinder	Part #	A	B	Weight
1510	57801	3/4"-16 UNF	2 1/8	2.2
2013/2513	57802	1"-14 UNF	2 5/8	2.7
3217	57803	1 1/4"-12 UNF	3	2.9

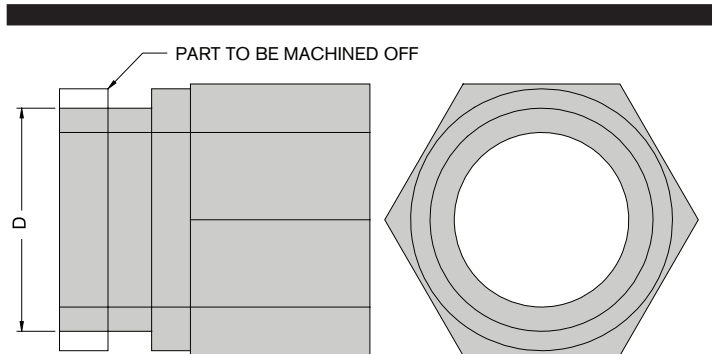

Series	Part #	Original Part #	D
200	57341	573201	1 1/4
203	57342	573202	1 7/16
208	57343	573203	1 11/16
300	57344	573204	1 15/16
308	57345	573205	2 3/16
400/408	57346	573206	2 5/8
500	57348	573208	2 7/8

PCP Pull Cylinders

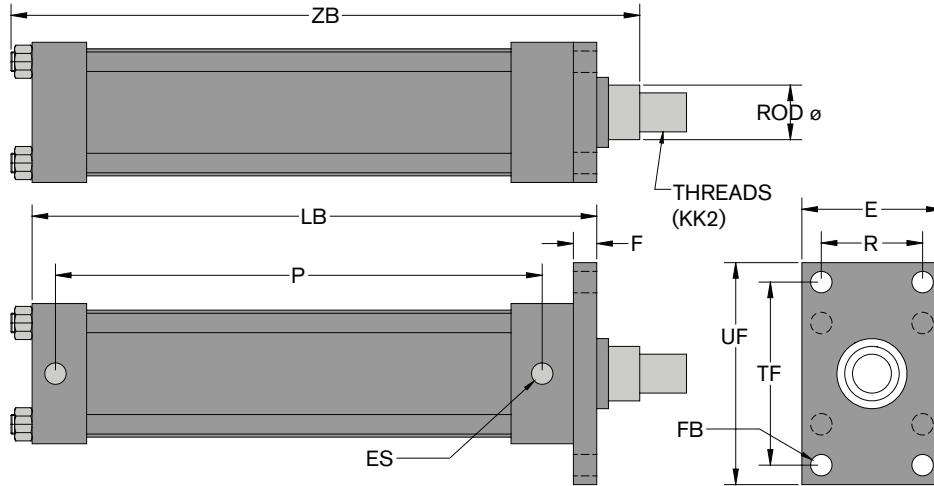

PCP Frame	Bore Dia	Rod Dia	Stroke	P	LB	ZB	F	ES	Threads (KK2)	E	UF	R	TF	FB	Approx. Weight
200	1 1/2	5/8	12	14 7/8	17	18 1/8	3/8	#8 or #10	7/16-20	2 1/2	4 1/4	1.63	3 7/16	7/16	15
			18	20 7/8	23	24 1/8									19
			24	26 7/8	29	30 1/8									23
			30	32 7/8	35	36 1/8									26
			36	38 7/8	41	42 1/8									30
203	1 1/2	5/8	12	14 7/8	17	18 1/8	3/8	#8 or #10	7/16-20	2 1/2	4 1/4	1.63	3 7/16	7/16	15
			18	20 7/8	23	24 1/8									19
			24	26 7/8	29	30 1/8									23
			30	32 7/8	35	36 1/8									26
			36	38 7/8	41	42 1/8									30
208	2	1	12	14 7/8	17 1/4	18 5/8	5/8	#8 or #10	3/4-16	3	5 1/8	2.05	4 1/8	9/16	20
			18	20 7/8	23 1/4	24 5/8									25
			24	26 7/8	29 1/4	30 5/8									30
			30	32 7/8	35 1/4	36 5/8									35
			36	38 7/8	41 1/4	42 5/8									40
300	2	1	12	14 7/8	17 1/4	18 5/8	5/8	#8 or #10	3/4-16	3	5 1/8	2.05	4 1/8	9/16	20
			18	20 7/8	23 1/4	24 5/8									25
			24	26 7/8	29 1/4	30 5/8									30
			30	32 7/8	35 1/4	36 5/8									35
			36	38 7/8	41 1/4	42 5/8									40

PCP Pull Cylinders

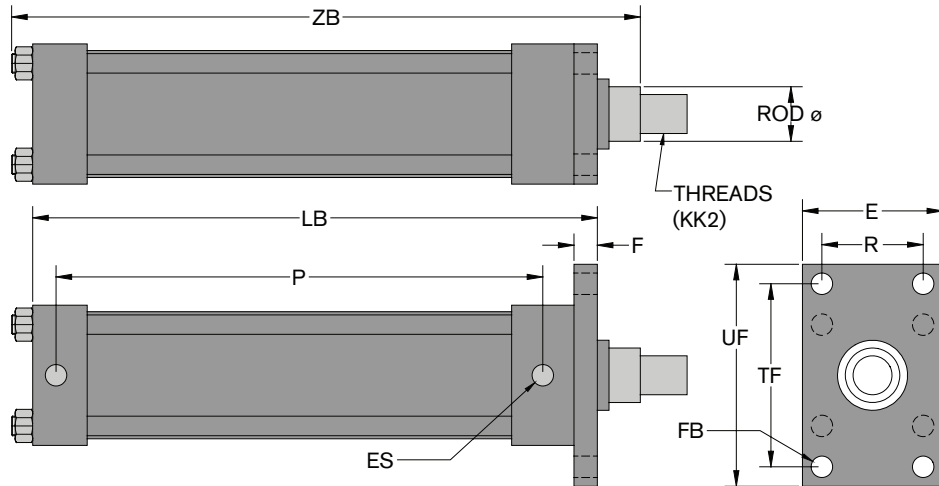

PCP Frame	Bore Dia	Rod Dia	Stroke	P	LB	ZB	F	ES	Threads (KK2)	E	UF	R	TF	FB	Approx. Weight
308	2 1/2	1	12	15	17 3/8	18 3/4	5/8	#8 or #10	3/4-16	3 1/2	5 5/8	2.55	4 5/8	9/16	35
			18	21	23 3/8	24 3/4									43
			24	27	29 3/8	30 3/4									50
			30	33	35 3/8	36 3/4									60
			36	39	41 3/8	42 3/4									68
400	3 1/4	1 3/8	12	15 19/32	18 1/4	19 7/8	3/4	#12	1-14	4 1/2	7 1/8	3.25	5 7/8	11/16	60
			18	21 19/32	24 1/4	25 7/8									70
			24	27 19/32	30 1/4	31 7/8									80
			30	33 19/32	36 1/4	37 7/8									90
			36	39 19/32	42 1/4	43 7/8									110
408	3 1/4	1 3/8	12	15 19/32	18 1/4	19 7/8	3/4	#12	1-14	4 1/2	7 1/8	3.25	5 7/8	11/16	60
			18	21 19/32	24 1/4	25 7/8									70
			24	27 19/32	30 1/4	31 7/8									80
			30	33 19/32	36 1/4	37 7/8									90
			36	39 19/32	42 1/4	43 7/8									110
500	3 1/4	1 3/8	12	15 19/32	18 1/4	19 7/8	3/4	#12	1-14	4 1/2	7 1/8	3.25	5 7/8	11/16	60
			18	21 19/32	24 1/4	25 7/8									70
			24	27 19/32	30 1/4	31 7/8									80
			30	33 19/32	36 1/4	37 7/8									90
			36	39 19/32	42 1/4	43 7/8									110

PCP Push Cylinders

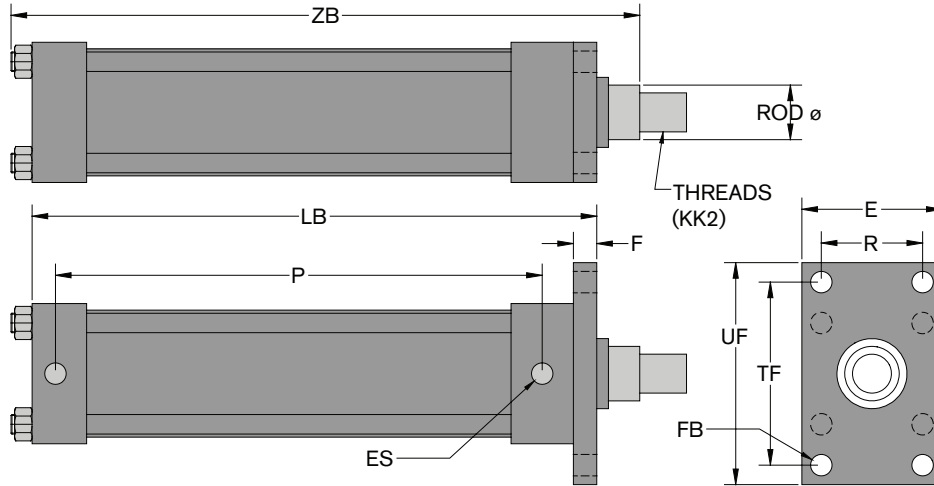

PCP Frame	Bore Dia	Rod Dia	Stroke	P	LB	ZB	F	ES	Threads (KK2)	E	UF	R	TF	FB	Approx. Weight
200	1 1/2	1	12	14 7/8	17	18 1/2	3/8	#8 or #10	3/4-16	2 1/2	4 1/4	1.63	3 7/16	7/16	15
			18	20 7/8	23	24 1/2									19
			24	26 7/8	29	30 1/2									23
			30	32 7/8	35	36 1/2									26
			36	38 7/8	41	42 1/2									30
203	1 1/2	1	12	14 7/8	17	18 1/2	3/8	#8 or #10	3/4-16	2 1/2	4 1/4	1.63	3 7/16	7/16	15
			18	20 7/8	23	24 1/2									19
			24	26 7/8	29	30 1/2									23
			30	32 7/8	35	36 1/2									26
			36	38 7/8	41	42 1/2									30
208	2	1 3/8	12	14 7/8	17 1/4	18 7/8	5/8	#8 or #10	1-14	3	5 1/8	2.05	4 1/8	9/16	20
			18	20 7/8	23 1/4	24 7/8									25
			24	26 7/8	29 1/4	30 7/8									30
			30	32 7/8	35 1/4	36 7/8									35
			36	38 7/8	41 1/4	42 7/8									40
300	2	1 3/8	12	14 7/8	17 1/4	18 7/8	5/8	#8 or #10	1-14	3	5 1/8	2.05	4 1/8	9/16	20
			18	20 7/8	23 1/4	24 7/8									25
			24	26 7/8	29 1/4	30 7/8									30
			30	32 7/8	35 1/4	36 7/8									35
			36	38 7/8	41 1/4	42 7/8									40

PCP Push Cylinders

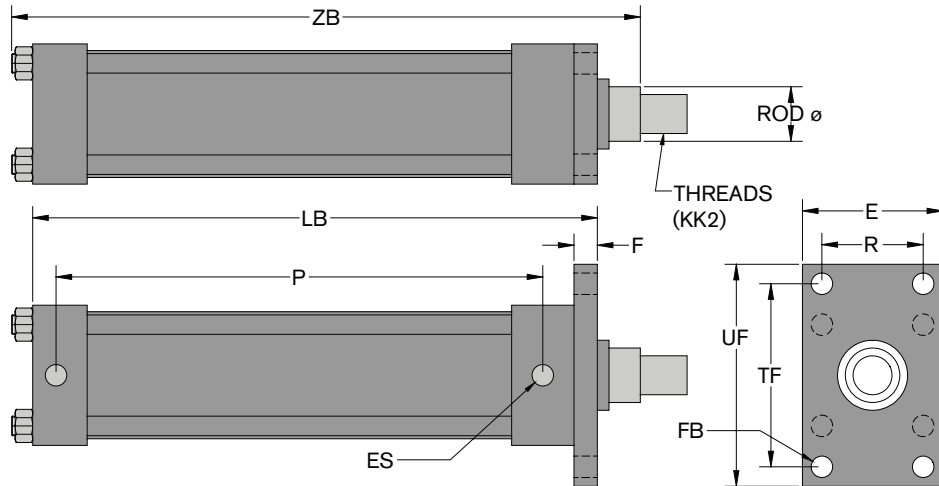

PCP Frame	Bore Dia	Rod Dia	Stroke	P	LB	ZB	F	ES	Threads (KK2)	E	UF	R	TF	FB	Approx. Weight
308	2 1/2	1 3/8	12	15	17 3/8	19	5/8	#8 or #10	1-14	3 1/2	5 5/8	2.55	4 5/8	9/16	35
			18	21	23 3/8	25									43
			24	27	29 3/8	31									50
			30	33	35 3/8	37									60
			36	39	41 3/8	43									68
400	3 1/4	1 3/4	12	15 19/32	18 1/4	20 1/8	3/4	#12	1 1/4-12	4 1/2	7 1/8	3.25	5 7/8	11/16	60
			18	21 19/32	24 1/4	26 1/8									70
			24	27 19/32	30 1/4	32 1/8									80
			30	33 19/32	36 1/4	38 1/8									90
			36	39 19/32	42 1/4	44 1/8									110
408	3 1/4	1 3/4	12	15 19/32	18 1/4	20 1/8	3/4	#12	1 1/4-12	4 1/2	7 1/8	3.25	5 7/8	11/16	60
			18	21 19/32	24 1/4	26 1/8									70
			24	27 19/32	30 1/4	32 1/8									80
			30	33 19/32	36 1/4	38 1/8									90
			36	39 19/32	42 1/4	44 1/8									110
500	3 1/4	1 3/4	12	15 19/32	18 1/4	20 1/8	3/4	#12	1 1/4-12	4 1/2	7 1/8	3.25	5 7/8	11/16	60
			18	21 19/32	24 1/4	26 1/8									70
			24	27 19/32	30 1/4	32 1/8									80
			30	33 19/32	36 1/4	38 1/8									90
			36	39 19/32	42 1/4	44 1/8									110