

MEDIUM DUTY SLIDER BED

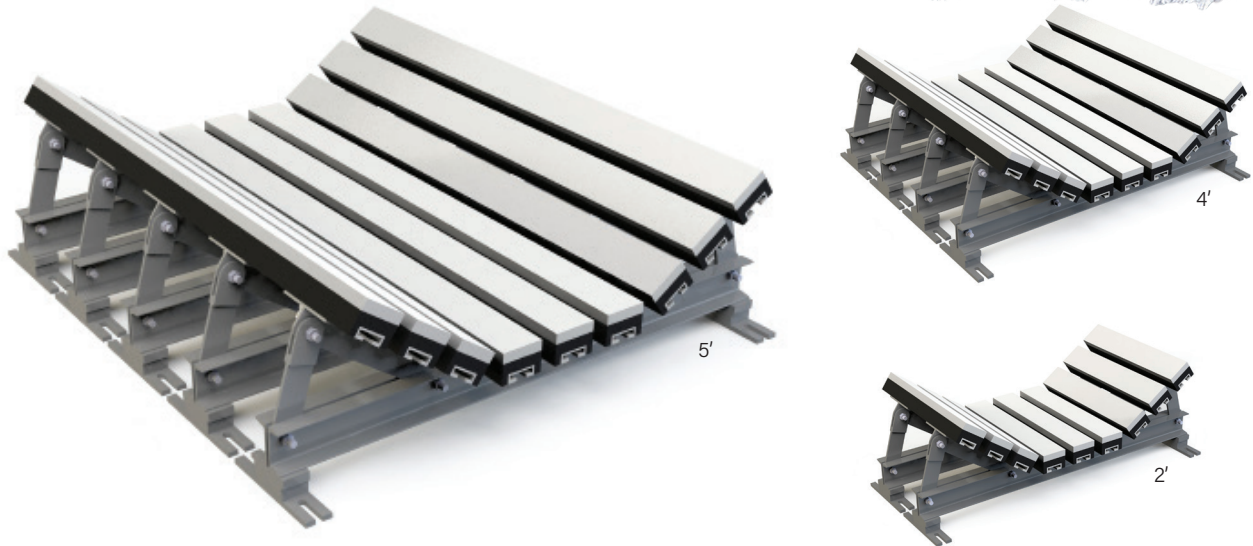

PPI is proud to offer the medium duty slider bed; a cost effective solution for your impact and loading zone requirements. This slider bed is an ideal combination of impact absorption and belt support promoting a tight seal against skirting system. A modular design, available in 2', 4' and 5' lengths with foldable wings allowing the user to configure to their unique needs.

FEATURES AND BENEFITS

- Simple, cost effective way to provide continuous support of the conveyor belt against the skirting material
- Ultra-high-molecular-weight (UHMW) slider rails for skirt board sealing
- No moving parts
- Seals skirt boards in loading zone to reduce spillage
- Supports conveyor belt in loading zone
- C-Channel frames for increased strength
- Fold-down wings for ease of maintenance
- Modular design allows multiple units to be fitted end-to-end to form the length needed
- Match center-roll height of CEMA C and D idlers
- Available in belt widths from 18" through 72"

MEDIUM DUTY SLIDER BED



MEDIUM DUTY SLIDER BED PART NUMBERING

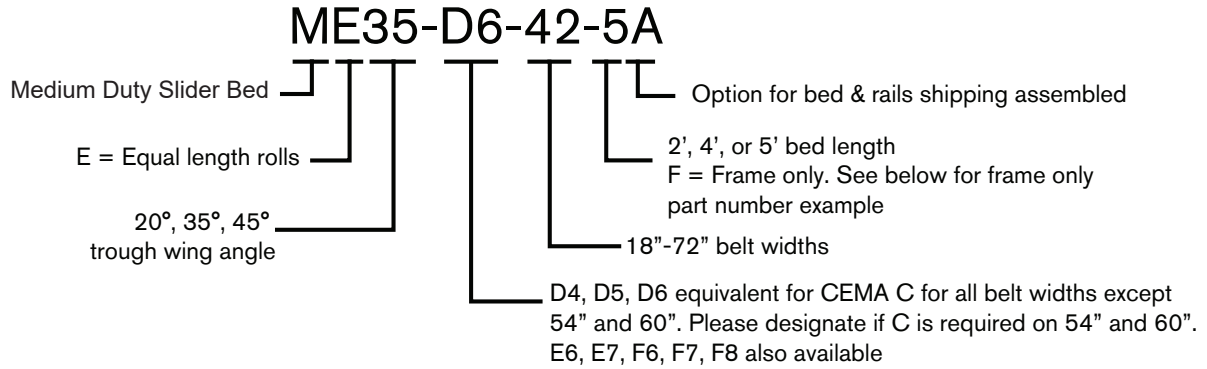

SLIDER RAIL & HARDWARE REPLACEMENT PARTS

ITEM	PART NUMBERS
2' RAIL	SRAIL 2
4' RAIL	SRAIL 4
5' RAIL	SRAIL5
T-BOLT*	44253
1/2" CONICAL SELF LOCKING HEX NUT	513200
1/2" FLAT WASHER	511190
HARDWARE SHIM*	504113

FRAME ONLY

Example: ME35-D6-42F

Please note: No rails included.

Frames will come with hardware in separate box.

WING SUPPORT HARDWARE

5/8" x 2" long bolt: P/N 500390

5/8" conical self-locking hex nut: P/N 513201

*Diagrams shown below

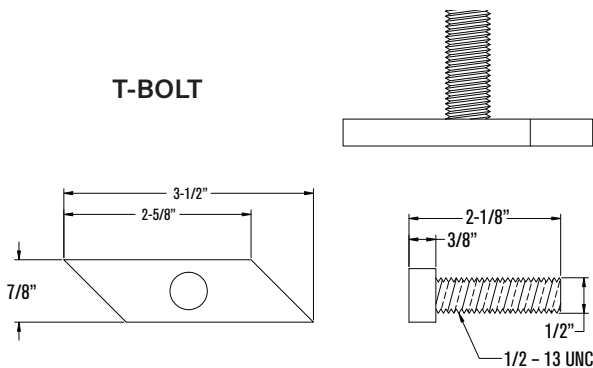

HARDWARE SHIM

