

The PPI Pro Tracker is a return training idler made up of a tubular roll mounted on a sealed for life ball bearing in the center of the tube. The idler pivots on an inclined, fixed swivel pin. If the belt moves to one side, this side moves downward and forward, skewing the roller and guiding the belt to its central position.

### **IMPORTANT – SAFETY INSTRUCTIONS**

Compliance with safety standards, including OSHA and other federal, state and local codes or regulations, is the responsibility of the user of the conveyor installation. Placement of guards and other safety equipment in accordance with safety standards is dependent upon the area and use of the system. A safety study should be made of the conveyor application and guards should be installed wherever appropriate. *Safety Standards of Conveyors and Related Equipment* ANSI B20.1 is a guide for safe construction, installation, operation and maintenance of conveyors and related equipment.

The stated purpose of ANSI Standard B20.1 is to present certain guidelines and safety practices that will assist in establishing a safe work place. It is important to realize that the best design and safety features can be useless in conjunction with faulty maintenance and operating practices.

The broad scope of ASME/ANSI Standard B20.1 precludes its inclusion in this manual. However, it is highly recommended that those responsible for assuring safety in the installation, operation and maintenance of belt conveyors and equipment, acquire and use Standard B20.1 as a reference and guide.

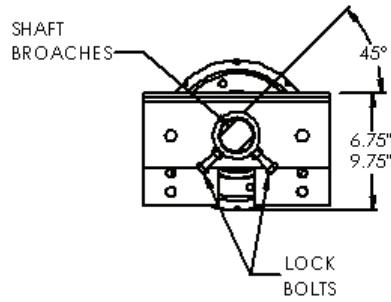

FIG 1

Pro Trackers are shipped with mounting brackets located at customer specified bolt centers. The mounting brackets are assembled as shown in FIG 1. This helps protect the mounting bracket and the shaft ends. Bolts used to mount the Pro Tracker to the conveyor structure are not included. Normally four mounting bolts are required.



FIG 2

If installing the Pro Tracker on a conveyor that is currently being used. Remove the current return idler roll and drop brackets from the location the Pro Tracker is to be installed. FIG 2 shows this general arrangement.

To begin installation of the Pro Tracker: Remove the drop brackets from the Pro Tracker. Then loosely bolt the Pro Tracker drop brackets into place below belt conveyor frame side stringer. See FIG 3.

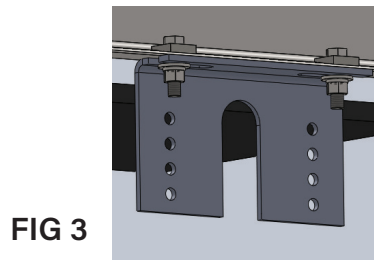

FIG 3

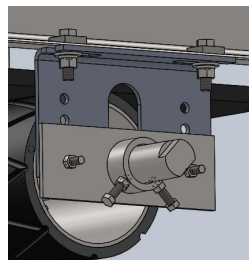

FIG 4

Next, raise the Pro Tracker up to the belt and secure bolts connecting the bracket on the shaft to the drop bracket. See FIG 4. Try to manually rotate or swivel the Pro Tracker. If you can rotate or swivel the Pro Tracker with ease, raise the Pro Tracker one more inch.

NOTE: Pro Tracker has 4 holes 1" apart on the drop bracket.

BELT WIDTH	PPI PRO TRACKER LOAD RATING		
	SBR P/N	URETHANE P/N	LOAD RATING (lbs)
18	TRACK-18L8DA	TRACK-18U8	1225
24	TRACK-24L8DA	TRACK-24U8	1210
30	TRACK-30L8DA	TRACK-30U8	1035
36	TRACK-36L8DA	TRACK-36U8	895
42	TRACK-42L8DA	TRACK-42U8	690
48	TRACK-48L8DA	TRACK-48U8	540
54	TRACK-54L8DA	TRACK-54U8	420
60	TRACK-60L8DA	TRACK-60U8	330
66	TRACK-66L8DA	TRACK-66U8	255
72	TRACK-72L8DA	TRACK-72U8	195

**CHART 1**

Next, the shaft in the Pro Tracker will need to be checked to see if it is perpendicular to conveyor centerline, level from shaft end to shaft end, centered between the conveyor stringers, and oriented in the direction of belt travel. See CEMA Conveyor Handbook, Appendix D for guidelines on how the conveyor centerline is determined.

To verify if the Pro Tracker is perpendicular to the belt, see FIG 5 as a reference drawing, measure distances Z1 and Z2 from a known item perpendicular to the belt, i.e. return roll.

To determine if the Pro Tracker shaft is level, measure X1 and X2 in FIG 6 from the surface the trougher idlers are mounted on. Dimensions Y1 and Y2 in FIG 6 can be used to determine if the Pro Tracker is centered between the belt conveyor frame side stringers. The measured distances should be within 1/8" (3 mm) of each other.

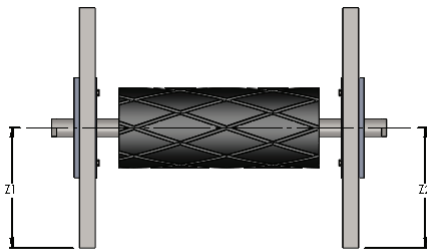

**FIG 5**



**FIG 6**

Next tighten bolts connecting the brackets on the shaft to drop brackets and drop brackets to the conveyor frame stringer. See FIG 4.

The Pro Tracker must be installed with the correct orientation relative to the direction of belt travel. First, determine the direction of belt travel. Then the shaft broach will need to lean 45° in the direction of belt travel. See FIG 7.

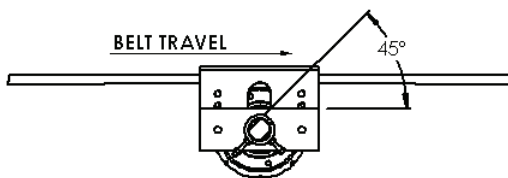

**FIG 7**

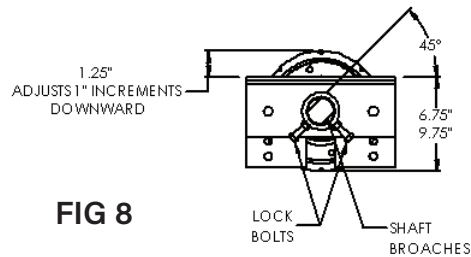

**FIG 8**

To adjust the direction of the broaches on the Pro Tracker, first loosen the four lock bolts and jam nuts on the shaft. Using an adjustable wrench on the broach, rotate the shaft to the desired location. Tighten all four lock bolts and jam nuts to keep the shaft from rotating. See FIG 8.

The vertical height of the Pro Tracker is adjustable in 1 inch increments. This is measured from the top of the drop bracket to the bottom of the roll, 6 3/4" to 9 3/4" as shown in FIG 8. The vertical height can also be measured from the top of the drop bracket to the top of the roll. FIG 8, shows the top of the idler roll 1.25" above the drop bracket. The top of the roll can be lowered to 1.75" below the top of the drop bracket.

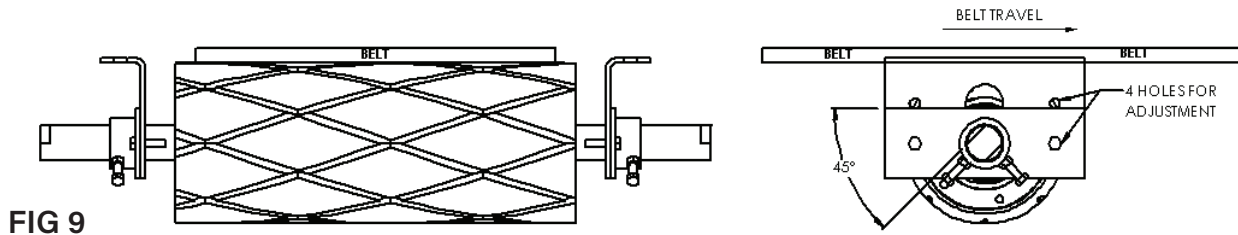
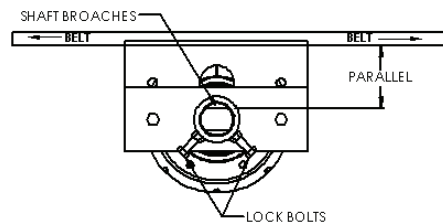

**FIG 9**

FIG 9 shows the Pro Tracker shaft centered and level. The shaft is oriented with belt travel.

### REVERSING BELT OPTION

Install the Pro Tracker as stated above. Since the belt can go either direction. The Pro Tracker shaft broach will need to be parallel to the belt. See FIG 10.



**FIG 10**

To adjust the direction of the broaches on the Pro Tracker, first loosen the four lock bolts and jam nuts on the shaft. Using an adjustable wrench on the broach, rotate the shaft to the desired location. Then tighten all four lock bolts and jam nuts to keep the shaft from rotating. See FIG 10.

### POSITION ON THE CONVEYOR

The Pro Tracker can take the place of a return idler on the conveyor. Pro Trackers should be approximately 50 feet (15 meters) from any terminal or bend pulley. Although in problem areas they can be placed as close as 5 times the belt width distance from a terminal or bend pulley.

Spacing between Pro Trackers should be 100 to 150 feet (31 to 46 meters) apart. At least one Pro Tracker should be used on conveyors less than 100 feet (31 meters) long.

The Pro Tracker should not be used in areas of belt transitions or other areas of high belt tension. Pro Trackers should not be used in a vertical curve or horizontal curve.

### ALTERNATIVE MOUNTING OPTION

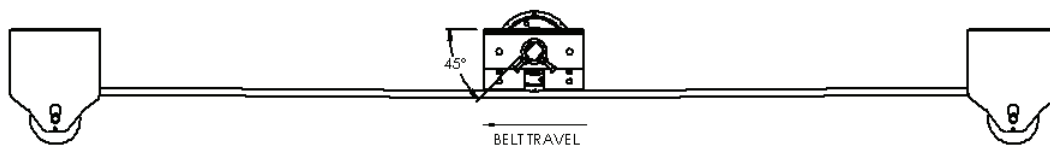

**FIG 11**

The Pro Tracker can also be installed on the top side of the return run of the conveyor belt. The Pro Tracker should be centered between two existing return idlers. FIG 11 shows the general arrangement. The return idlers adjacent to the Pro Tracker will be subject to extra load from the Pro Tracker in addition to the weight of the belt and may need to be replaced with heavier idlers. Because of this loading, plastic rolls should not be used in the adjacent return idlers.

## LOAD CALCULATION EXAMPLES FOR ALTERNATIVE MOUNTING OPTION

**EXAMPLE 1** for calculating load on Pro Tracker and Return Idlers FIG 12:

- Using CEMA C5 inch diameter return idlers with a 4-1/2" drop bracket, given belt width of 48 inch, belt weight of 15 pounds per foot and belt tension of 14,000 pounds.
- The B dimension is 5-3/8 inch.

$$\text{Load on TRACKER (lb)} = \frac{B(\text{in}) \times \text{Belt Tension (lb)}}{3 \times C(\text{ft})} = \frac{5.375 \times 14,000}{(3 \times 8)} = \mathbf{3135 \text{ pounds}}$$

$$\text{Load on Return Idlers (lb)} = \frac{\text{Load on TRACKER (lb)}}{2} + \text{Belt Weight} \frac{\text{lb}}{\text{ft}} \times \text{Return Idler Spacing (ft)}$$

$$\text{Load on Return Idlers (lb)} = \frac{3135}{2} + 15 \times 8 = 1568 + 120 = \mathbf{1688 \text{ pounds}}$$

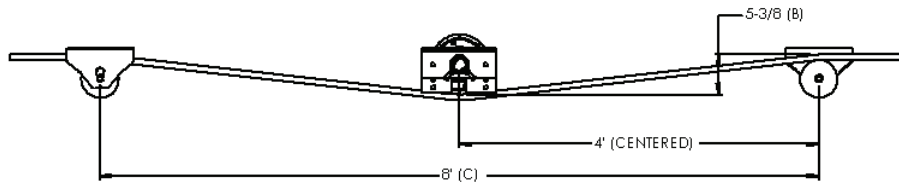

**FIG 12**

**EXAMPLE 1** calculations indicate that the Pro Tracker will be over loaded as will be the adjacent return rolls.

To verify if the Pro Tracker will be overloaded, use CHART 1 on page 3. In the far left column under "BELT" find 48. Move to the right, find 540 under column heading "LOAD RATING". See FIG 13

For Example 1 above, 3135 pounds is calculated which is close to 6 times the recommended load rating of the Pro Tracker.

BELT WIDTH	PPI PRO TRACKER LOAD RATING		
	SBR P/N	URETHANE P/N	LOAD RATING (lbs)
18	TRACK-18L8DA	TRACK-18U8	1225
24	TRACK-24L8DA	TRACK-24U8	1210
30	TRACK-30L8DA	TRACK-30U8	1035
36	TRACK-36L8DA	TRACK-36U8	895
42	TRACK-42L8DA	TRACK-42U8	690
<b>48</b>	TRACK-48L8DA	TRACK-48U8	<b>540</b>
54	TRACK-54L8DA	TRACK-54U8	420
60	TRACK-60L8DA	TRACK-60U8	330
66	TRACK-66L8DA	TRACK-66U8	255
72	TRACK-72L8DA	TRACK-72U8	195

**FIG 13**

To verify if the adjacent Return Rolls will be overloaded. Find CHART 2 on page 8. Look for column labelled "C (P204)", go down the column until across from 48 in "BELT WIDTH" column. 125 should be where column "C (P204)" and row "48" cross. See FIG 14.

For Example 1 above, 1688 pounds is calculated which is over 10 times the recommended load rating of a CEMA C (P204) Return Roll.

BELT WIDTH	SINGLE ROLL RETURN LOAD RATING (lbs)						
	B (6203)	C (P204)	D (6305)	D+ (6306)	E (6307)	E+ (6308)	F (6310)
18	220	475	-	-	-	-	-
24	190	325	600	950	-	-	-
30	165	250	600	940	-	-	-
36	155	200	600	930	1,000	1,200	-
42	140	150	500	920	1,000	1,200	-
48	125	125	425	910	1,000	1,200	-
54	-	USE CEMA D (6305)	375	905	925	1,110	-
60	-		280	850	850	1,020	1,500
66	-		215	700	775	930	1,350
72	-		155	560	700	840	1,200

FIG 14

How can the loads be reduced? Dimension "B" in Example 1 needs to be smaller than 5.375". Reduce that dimension by raising the Pro Tracker up from the belt or lowering the return rolls. Example 2 calculation will be done with a smaller Dimension B.

**EXAMPLE 2** for calculating load on Pro Tracker and Return Idlers FIG 15:

- Using CEMA C5 inch diameter return idlers with a 9" drop bracket, given belt width of 48 inch, belt weight of 15 pounds per foot and belt tension of 14,000 pounds.
- The B dimension is 7/8 inch.

$$\text{Load on TRACKER (lb)} = \frac{B(\text{in}) \times \text{Belt Tension (lb)}}{3 \times C (\text{ft})} = \frac{0.875 \times 14,000}{(3 \times 8)} = 510 \text{ pounds}$$

$$\text{Load on Return Idlers (lb)} = \frac{\text{Load on TRACKER (lb)}}{2} + \text{Belt Weight} \frac{\text{lb}}{\text{ft}} \times \text{Return Idler Spacing (ft)}$$

$$\text{Load on Return Idlers (lb)} = \frac{510}{2} + 15 \times 8 = 255 + 120 = 375 \text{ pounds}$$

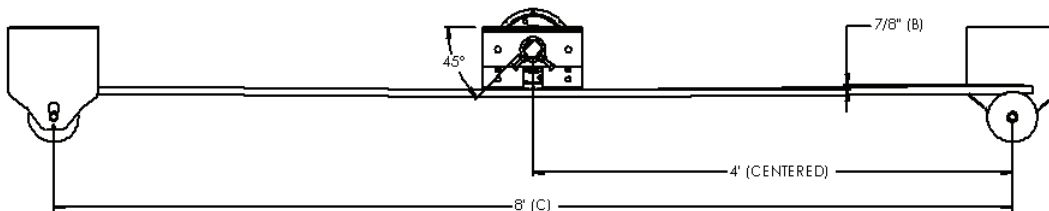

FIG 15

Example 2 calculations indicate that the Pro Tracker will be within the load rating on CHART 1. See FIG 13 to find the load rating is 540 pounds. According to CHART 2, the adjacent return rolls will be overloaded. A load of 375 pounds is greater than the CEMA C (P204) 125 pound load rating. The red arrows in FIG 16 point to a CEMA C (P204) single roll return. The CEMA C5 return rolls can be replaced by CEMA D5 return rolls. CEMA D (6305) will increase the load rating to 425 pounds. The green arrows in FIG 16 point to a CEMA D (6305) single roll return.

BELT WIDTH	SINGLE ROLL RETURN LOAD RATING (lbs)						
	B (6203)	C (P204)	D (6305)	D+ (6306)	E (6307)	E+ (6308)	F (6310)
18	220	475	-	-	-	-	-
24	190	325	600	950	-	-	-
30	165	250	600	940	-	-	-
36	155	200	600	930	1,000	1,200	-
42	140	150	500	920	1,000	1,200	-
48	125	125	425	910	1,000	1,200	-
54	-	USE CEMA D (6305)	375	905	925	1,110	-
60	-		280	850	850	1,020	1,500
66	-		215	700	775	930	1,350
72	-		155	560	700	840	1,200

FIG 16

BELT WIDTH	SINGLE ROLL RETURN LOAD RATING (lbs)						
	B (6203)	C (P204)	D (6305)	D+ (6306)	E (6307)	E+ (6308)	F (6310)
18	220	475	-	-	-	-	-
24	190	325	600	950	-	-	-
30	165	250	600	940	-	-	-
36	155	200	600	930	1,000	1,200	-
42	140	150	500	920	1,000	1,200	-
48	125	125	425	910	1,000	1,200	-
54	-	USE CEMA D (6305)	375	905	925	1,110	-
60	-		280	850	850	1,020	1,500
66	-		215	700	775	930	1,350
72	-		155	560	700	840	1,200

CHART 2

## MAINTENANCE

All moving parts of the Pro Tracker are shipped lubricated for life and no further lubrication is necessary.

Periodically check to ensure that all moving parts are free of debris and able to move freely.

Periodically check the lagging for excessive wear and replace the Pro Tracker if necessary.

## PPI PRO TRACKER PART NUMBERS

PPI PRO Tracker - 1/2" SBR Diamond LAG						
Part Number	Belt Width	Weight (lbs)	A	C	G	DIA
TRACK-18L8DA	18	102.0	27	33.5	20	8
TRACK-24L8DA	24	115.0	33	39.5	26	8
TRACK-30L8DA	30	128.0	39	45.5	32	8
TRACK-36L8DA	36	142.0	45	51.5	38	8
TRACK-42L8DA	42	155.0	51	57.5	44	8
TRACK-48L8DA	48	168.0	57	63.5	50	8
TRACK-54L8DA	54	181.0	63	69.5	56	8
TRACK-60L8DA	60	194.0	69	75.5	62	8
TRACK-66L8DA	66	208.0	75	81.5	68	8
TRACK-72L8DA	72	221.0	81	87.5	74	8

PPI PRO Tracker - 1/2" Urethane LAG						
Part Number	Belt Width	Weight (lbs)	A	C	G	DIA
TRACK-18U8	18	103.0	27	33.5	20	8
TRACK-24U8	24	116.0	33	39.5	26	8
TRACK-30U8	30	129.0	39	45.5	32	8
TRACK-36U8	36	143.0	45	51.5	38	8
TRACK-42U8	42	156.0	51	57.5	44	8
TRACK-48U8	48	170.0	57	63.5	50	8
TRACK-54U8	54	183.0	63	69.5	56	8
TRACK-60U8	60	196.0	69	75.5	62	8
TRACK-66U8	66	210.0	75	81.5	68	8
TRACK-72U8	72	223.0	81	87.5	74	8

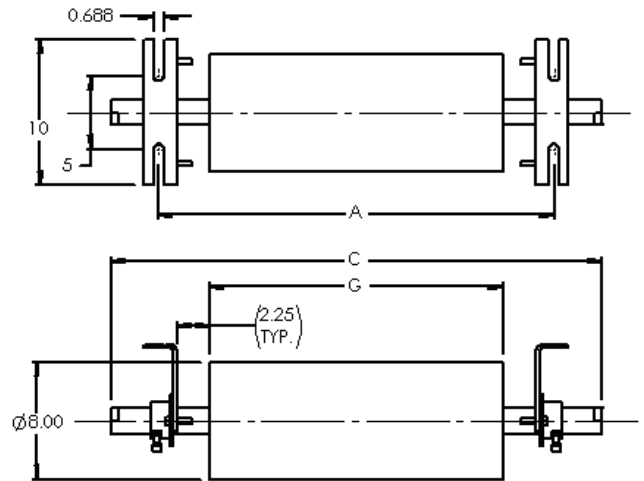
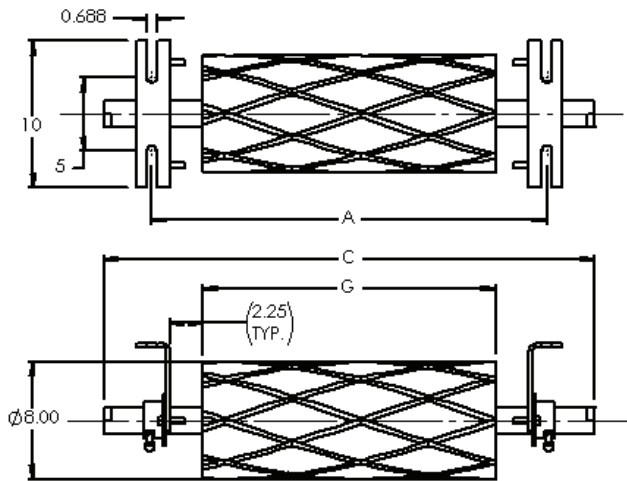

**CORPORATE OFFICE** • P.O. Box 287 • Pella, IA 50219  
 800.247.1228 • 641.628.3115 • 641.628.3658 FAX