

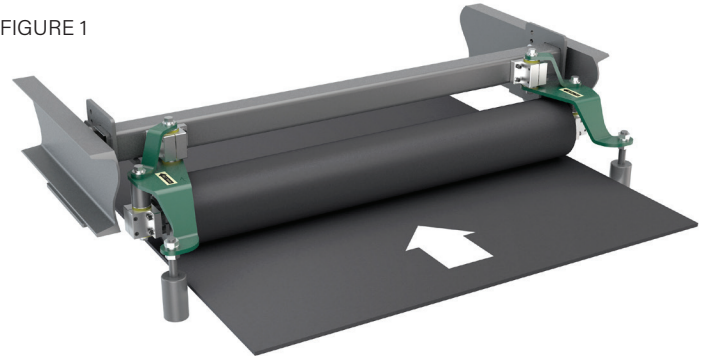

OPERATION & MAINTENANCE
PRO TRAINER

The Pro Trainer is designed to correct lateral belt misalignment by providing a positive steering force to return the belt to its intended path. It is intended to be installed on the top side of the return run of the conveyor belt as shown in Figure 1. When properly installed the Pro Trainer will cause a slight vertical deflection of the belt to ensure sufficient contact between the belt and the steering roller. The two guide rolls will be positioned off either edge of the belt with about 3/8 inch of clearance between each roll and the belt edge. As the belt wanders off its intended path, it will contact one of the guide rolls and cause the steering roll to skew slightly and provide a corrective steering force to the belt.

FIGURE 1



INSTALLATION

1. The Pro Trainer should be installed on the top side of the return run of the conveyor belt. It should be positioned so that the steering roll is centered between two existing return idlers. Figure 2 shows the preferred general arrangement.
2. The Pro Trainer will not function properly on reversing belts and must be installed with the correct orientation relative to the direction of belt travel as indicated in Figure 2.

FIGURE 2

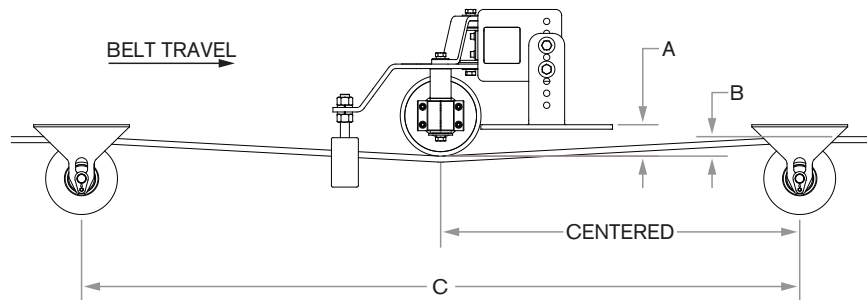

3. Since a portion of the Pro Trainer will be above the bottom edge of the conveyor framework, care must be taken to ensure that there is enough clearance within the framework for the Pro Trainer. Figure 3 indicates the clearance required.

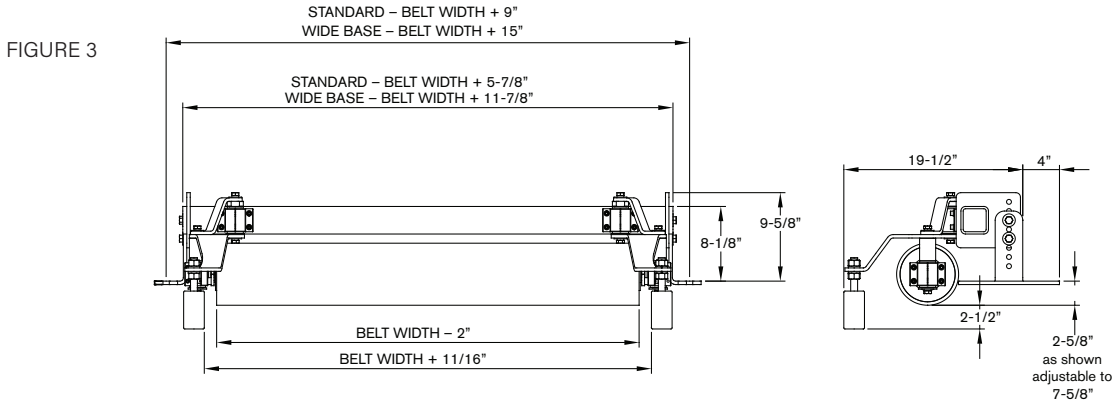

4. Figure 4 indicates the mounting dimensions for the Pro Trainer.

5. The vertical height (Dimension A, Figure 2) of the Pro Trainer is adjustable in 1 inch increments from 2-5/8 to 7-5/8 inches. The Pro Trainer is shipped with the height set to 2-5/8 inches. The belt deflection (Dimension B, Figure 2) should be kept to the minimum necessary for positive contact between the belt and steering roll in order to minimize the load on the Pro Trainer and the adjacent return idlers. The load imposed on the Pro Trainer can be calculated with the following formula:

$$\text{Load on Pro Trainer (lb)} = \frac{\text{Belt Deflection, B (in)} \times \text{Belt Tension (lb)}}{3 \times \text{Return Idler Spacing, C (ft)}}$$

The return idlers adjacent to the Pro Trainer will be subject to one half the load on the Pro Trainer in addition to the weight of the belt and may need to be replaced with heavier idlers.

Because of this loading plastic rolls should not be used in a ProTrainer or the adjacent return idlers.

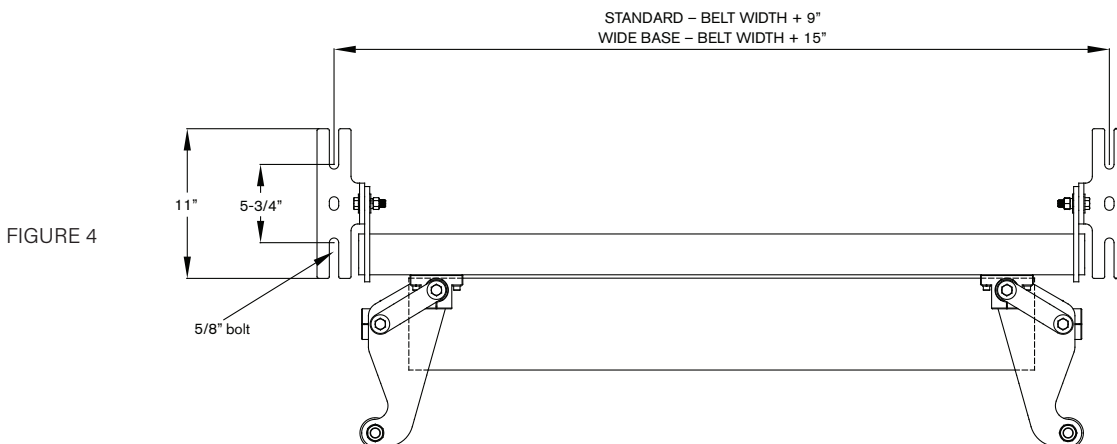

ALTERNATIVE MOUNTING OPTION

For very long drop brackets it may be necessary to turn over the Pro Trainer foot pad and point it downward. This arrangement allows the Pro Trainer to be adjusted downward farther than 7-5/8 inches and is shown in Figure 5. This allows the Pro Trainer to be adjusted downward farther than 7 5/8". Extra care must be taken to not overload the adjacent return idlers or the Pro Trainer. The load imposed on the Pro Trainer can be calculated with the following formula:

$$\text{Load on Pro Trainer (lb)} = \frac{B \text{ (in)} \times \text{Belt Tension (lb)}}{3 \times C \text{ (ft)}}$$

The return idlers adjacent to the Pro Trainer will be subject to one half the load on the Pro Trainer in addition to the weight of the belt and may need to be replaced with heavier idlers.

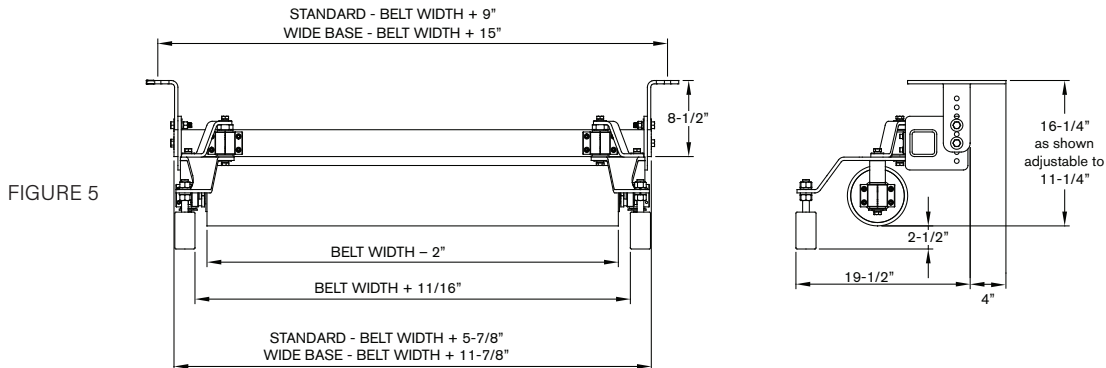

FIGURE 5

POSITION ON CONVEYOR

The ProTrainer should be approximately 50 feet (15 meters) from any terminal or bend pulley. Although in problem areas they can be placed as close as 5 times the belt width distance from a terminal or bend pulley.

Spacing between ProTrainers should be 100 to 150 feet (31 to 46 meters) apart. At least one ProTrainer should be used on conveyors less than 100 feet (31 meters) long.

The ProTrainer should not be used in areas of belt transitions or other areas of high belt tension. And should not be used in a vertical curve or horizontal curve.

LOAD CALCULATION EXAMPLES

EXAMPLE 1 for calculating load on Pro Trainer and Return Idlers Figure 6:

- Using CEMA D 6 inch diameter return idlers with a 4-1/2 inch drop bracket, given the belt width of 48 inch, belt weight of 15 pounds per foot and belt tension of 14,000 pounds.
- The B dimension is 1-5/8 inch

$$\text{Load on Pro Trainer (lb)} = \frac{B \text{ (in)} \times \text{Belt Tension (lb)}}{3 \times C \text{ (ft)}} = \frac{1.625 \times 14,000}{(3 \times 10)} = 758 \text{ pounds}$$

$$\text{Load on Return Idlers (lb)} = \frac{\text{Load on Pro Trainer (lb)}}{2} + \text{Belt Weight} \left(\frac{\text{lb}}{\text{ft}} \right) \times \text{Return Idler Spacing (ft)}$$

$$\text{Load on Return Idlers (lb)} = \frac{758}{2} + 15 \times 10 = 379 + 150 = 529 \text{ pounds}$$

FIGURE 6

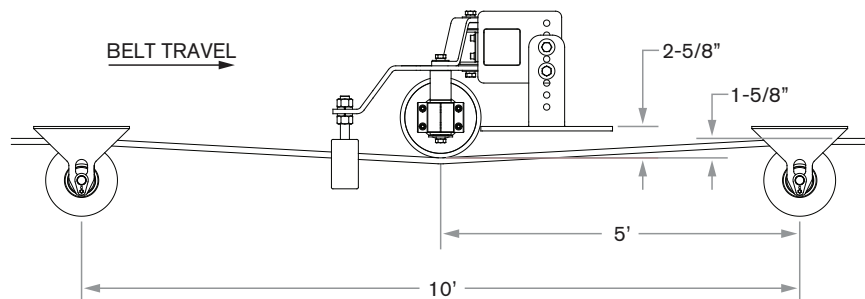

EXAMPLE 2 calculating load on Pro Trainer and Return Idlers Figure 7:

- Using CEMA D 5 inch diameter return idlers with a 4-1/2 inch drop bracket, given the belt width of 42 inch, belt weight of 12 pounds per foot and belt tension of 21,000 pounds.
- The B dimension is 1-1/8 inch

$$\text{Load on Pro Trainer (lb)} = \frac{B \text{ (in)} \times \text{Belt Tension (lb)}}{3 \times C \text{ (ft)}} = \frac{1.125 \times 21,000}{(3 \times 8)} = 984 \text{ pounds}$$

$$\text{Load on Return Idlers (lb)} = \frac{\text{Load on Pro Trainer (lb)}}{2} + \text{Belt Weight} \left(\frac{\text{lb}}{\text{ft}} \right) \times \text{Return Idler Spacing (ft)}$$

$$\text{Load on Return Idlers (lb)} = \frac{984}{2} + 12 \times 8 = 492 + 96 = 588 \text{ pounds}$$

FIGURE 7

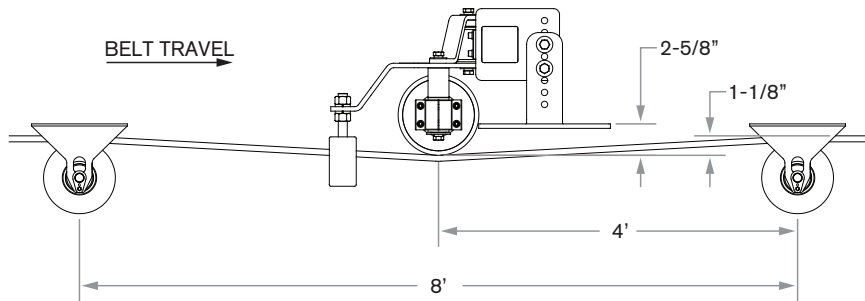

MAINTENANCE

1. All moving parts of the Pro Trainer are shipped lubricated for life and no further lubrication is necessary.
2. Periodically check to ensure that all moving parts are free of debris and able to move freely.
3. Periodically check the steering rolls and guide rolls for excessive wear and replace if necessary.

ProTrainer Replacement Roll Part Numbers

Belt Width	Part Number	Roll Part Number	Roll Length
24	PROT-24	E6P-VR-42SBM6	22
30	PROT-30	E6P-FL-24SBM6	28
36	PROT-36	E6P-FL-30SBM6	34
42	PROT-42	E6P-FL-36SBM6	40
48	PROT-48	E6P-FL-42SBM6	46
54	PROT-54	E6P-FL-48SBM6	52
60	PROT-60	E6P-FL-54SBM6	58
66	PROT-66	E6P-FL-60SBM6	64
72	PROT-72	E6P-FL-66SBM6	70
78	PROT-78	E6P-FL-72SBM6	76
84	PROT-84	E6P-FL-78SBM6	82
90	PROT-90	E6P-FL-84SBM6	88
96	PROT-96	E6P-FL-90SBM6	94

Guide Roll Replacement Part Number 34093

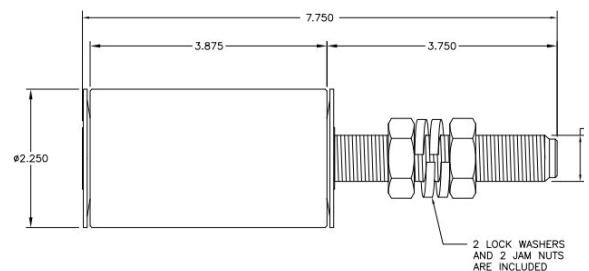

Replacement Guide Arm Assemblies

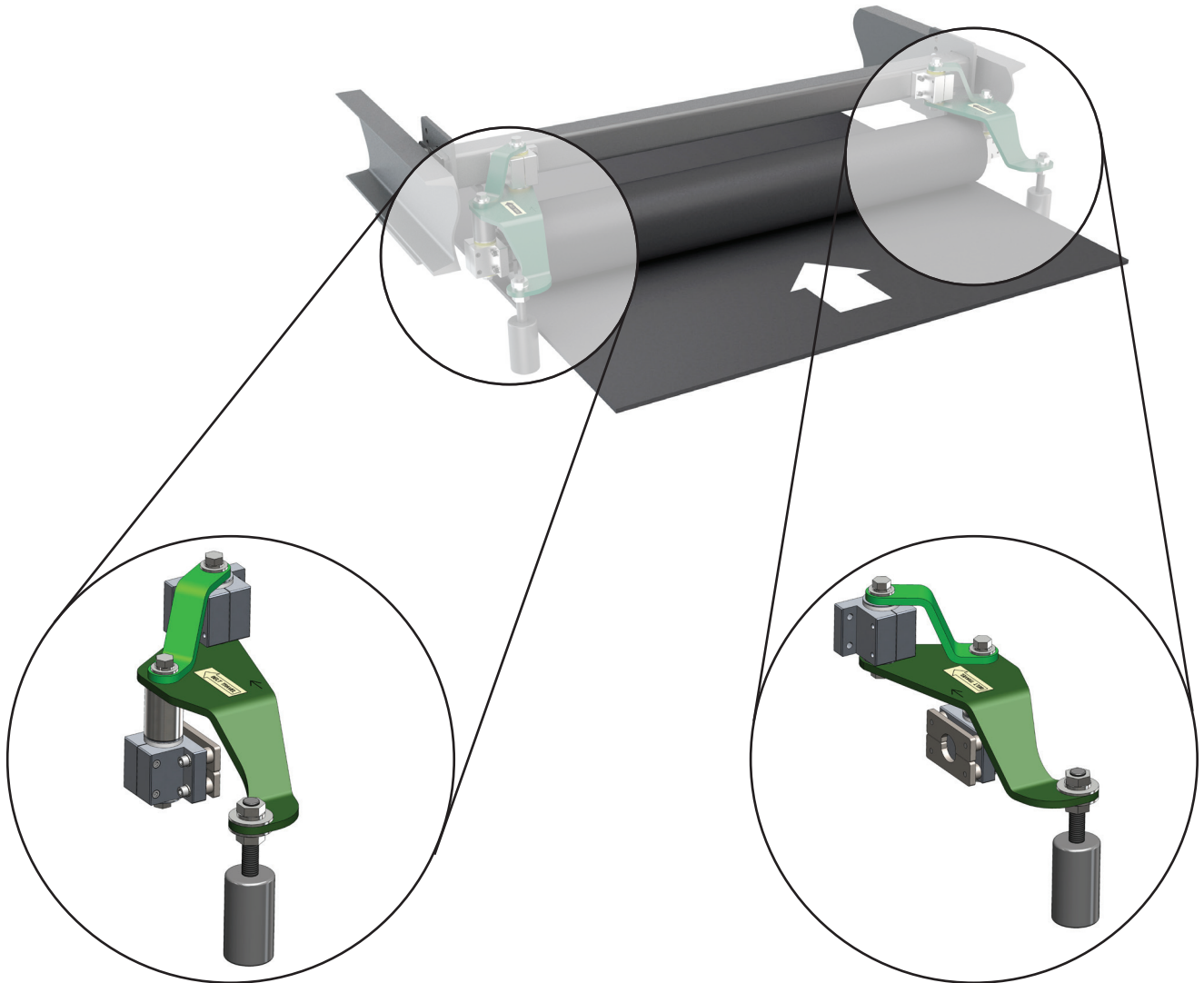

LEFT GUIDE ARM ASSEMBLY

PART NUMBER: 49290LKIT

Kit also includes:

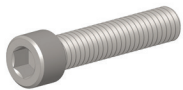

P/N: 500450 – QTY 4
5/16-18 x 1-1/2 Socket Head Cap



P/N: 510047 – QTY 4
5/16 Lock Washer

Mounting Hardware shipped in a separate box

RIGHT GUIDE ARM ASSEMBLY

PART NUMBER: 49290RKIT

Kit also includes:

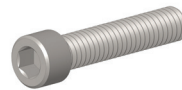

P/N: 500450 – QTY 4
5/16-18 x 1-1/2 Socket Head Cap



P/N: 510047 – QTY 4
5/16 Lock Washer

Mounting Hardware shipped in a separate box

LOAD RATINGS

ProTrainer Load Ratings

Belt	Part Number	Load Rating
24	PROT-24	1,200
30	PROT-30	1,200
36	PROT-36	1,200
42	PROT-42	1,200
48	PROT-48	1,200
54	PROT-54	1,200
60	PROT-60	1,110
66	PROT-66	1,020
72	PROT-72	930
78	PROT-78	840
84	PROT-84	720
90	PROT-90	605
96	PROT-96	520

CEMA Load Ratings

Belt Width	Single Roll Return					
	B	C	D	E	E+	F
18	220	475				
24	190	325	600			
30	165	250	600			
36	155	200	600	1,000	1,200	
42	140	150	500	1,000	1,200	
48	125	125	425	1,000	1,200	
54			375	925	1,110	
60			280	850	1,020	1,500
66			215	775	930	
72			155	700	840	1,200
78			125	625	720	
84				550	605	900
90				475	520	
96				400	440	600
102				250	275	



CORPORATE OFFICE • P.O. Box 287 • Pella, IA 50219
800.247.1228 • 641.628.3115 • 641.628.3658 FAX