



OPERATION & MAINTENANCE
CRAFT-LAG

Install Craft-Lag only on pulley diameters for which the pad has been factory formed. Modifying pad diameters outside of Precision factories is not recommended. Follow installation instructions exactly to ensure product safety.

SECTION 1 - GENERAL

STEP 1: Measure the actual pulley diameter prior to installation and determine the number of rows needed. Craft-lag is factory formed to even number diameters, for example 8", 10", 12" and up to 72". The center-to-center dimension of the installed pads is designed to be 6.28 or pi times two. The number of craft-lag rows needed is easily determined by dividing the pulley diameter by two. If the diameter is within ¼" of an even number, the number of rows required can be rounded to the nearest even number. If a pulley diameter is metric or an odd number diameter, consult Section 7 for proper installation.

STEP 2: Determine how the pads will be fastened to the pulley. There are two options:

1. Welded or bolted retainers
2. Welding the pads directly to the pulley

If Option 1 is chosen, there are two additional choices for securing the pads to prevent them from sliding out during operation:

1. Tack weld the ends of the pads
2. Bend the retainers over the edge of the pulley.

For bolted retainers, see Section 5. If you choose to tack weld the end of the pad to the pulley, the retainers can be cut to the same length as the pulley. However, if you choose to bend the retainer

over to lock the pad in place, you will need to cut the retainer 1" longer than the pulley face. In addition, the bent retainer option requires a full width tab at both ends and may require two pieces per retainer row to be accomplished.

STEP 3: Cutting the Craft-lag pads. Center crowned pulleys are recommended to have a minimum of two pieces per row that meet at the middle of the pulley face. This is necessary in order to maintain the crown. One piece installations are not warranted to "track" the belt. Edge crowned pulleys will need a minimum of three pieces per row. The splits are to coincide with the break in the pulley profile to maintain the crown. Minimum length of Craft-Lag pads used is 4" long. Maximum number of pieces per row should never exceed four. If installing step crown lagging, the length of the center pad with standard thickness is equal to pulley length minus the length of the two thinner pads at each end.

STEP 4. Clean the pulley, removing rust and any protrusions before installation and welding.

Remember if using bent over retainers, add one inch to the pulley length and then cut to ensure there is a full tab at each end.

SECTION 2 - NORMAL INSTALLATION WITHOUT RETAINERS

STEP 1: Align the first pad straight across the pulley face making it parallel to the shaft. Clamp it in place. When more than one pad is used in a row, be sure that all pads are parallel. Tack weld each length in three or four places.

STEP 2: Using the proper spacing between pads, install all of the remaining pads by repeating Step 1 above. The spacing will be either 3/4" for normal installation or some other dimension calculated from the non-standard installation procedure (see Section 7).

STEP 3: When all the pads have been tacked in place, complete the welding on each pad using the welding procedures outlined in Section 4.

PROPER ATTENTION TO CRAFT-LAG INSTALLATION PROCEDURES WILL ENSURE LONG AND TROUBLE-FREE SERVICE.

SECTION 3 - NORMAL INSTALLATION WITH RETAINERS

STEP 1: Align the first pad straight across the pulley face making it parallel to the shaft and clamp in place. When more than one pad is used in a row, be sure all pads are parallel.

STEP 2: Insert a double retainer on one side of the pad ensuring that the 1/32" clearance is maintained along the full length (See Figure 1). Clamp into place and plug weld it to the pulley face through 3 or 4 pre-punched holes using the procedures from Section 4. If using the bent over retainer method, the retainer should extend beyond the end of the pulley 1/2" so that it can be hammered over to hold it in place (See Figure 2).

STEP 3: Clamp the next retainer in place on the opposite edge of the pad. Secure the retainer by plug welding through 3 or 4 holes.

STEP 4: Repeat the above installation sequence until all pads except the last two are in place.

When installing Craft-Lag pads on crown faced pulleys, it is recommended that for each row a minimum of two pieces of Craft-Lag be used to meet in the center of the pulley at the crown peak or center. This will aid in the installation process and maintain pulley crown.

FIGURE 1

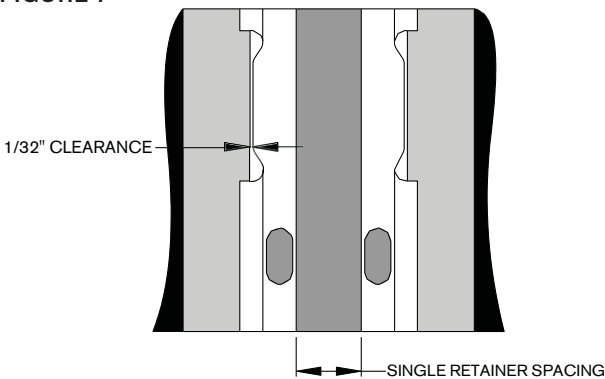

STEP 5: Install the two single retainers back-to-back in the gap between the last two pads (See Figure 1). Use the same welding procedures and clearances as described for the double retainers. The space between the single retainers will vary slightly according to the actual pulley diameter. However, the gap should not exceed the limits given in Section 1. Otherwise, non-standard installation is required.

STEP 6: Complete plug welding all of the remaining holes following the welding procedures shown in Section 4.

STEP 7: Pound the retainer lips down tight against the pad backing plates using a hammer and an appropriate bar or punch.

STEP 8: There are several ways of locking the pads into place to prevent them from "walking" out during running. If using the bent-over procedure, you will need to bend the retainer lip down and curl around pulley rim.

STEP 9: If using the welding method, be sure to tack weld both ends of each pad row. The tack weld should be on the edge of the rim so that it will be easy to grind or chisel off for pad replacement later. Replacement pads should also be tacked in place after installation.

FIGURE 2

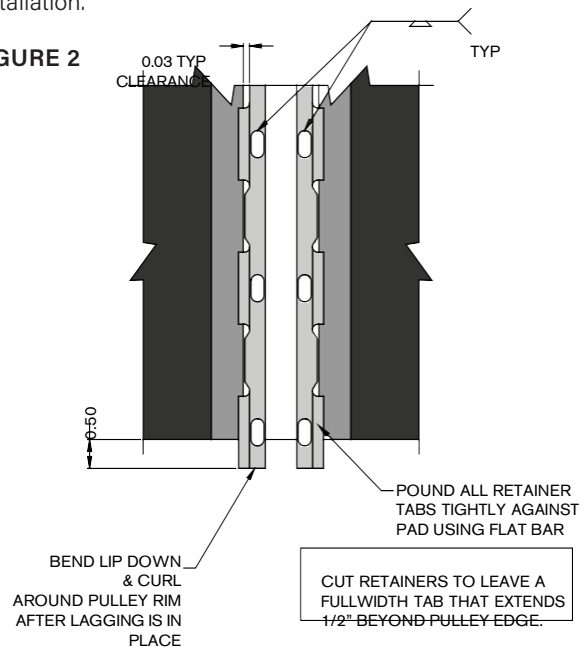

SECTION 4 - WELDING PROCEDURES

STEP 1: If welding with rod, use 3/32" diameter AWS E7018 to limit heat build-up and possibly burn through.

STEP 2: Avoid excessive heat transfer to the rubber portion of the pad by:

1. WITH RETAINERS: Plug welding only 1/2 of a retainer hole at a time, skipping from hole to hole and retainer to retainer until all welding is completed.
2. WITHOUT RETAINERS: Placing weld beads along each pad edge in 3/8" to 1/2" increments, skipping from place to place until welding is completed. The finished weld beads should be about 5/8" to 1" long and spaced on approximately 3" centers.

3. Cover the rubber in the welding area with a length of angle iron for protection.
4. Using a brass heat sink bar or a wet rag to cool the metal.
5. In all cases, heat must be controlled to prevent damage to the rubber and the rubber-to-metal bond.

STEP 3: MIG and TIG welding may be used for attaching Craft-Lag welding rod meeting AWS E309 should be used to weld stainless steel pads or retainers to steel pulleys.

STEP 4: Use welding rod meeting AWS A5.15 for attaching Craft-Lag pads or retainers to cast iron pulleys. Note that other standard cast iron welding procedures and cautions may also be necessary.

STEP 5: Always ensure good contact between the pad backing plate or retainer and the pulley surface at the weld by applying downward pressure during welding with some convenient tool such as a wooden handle.

STEP 6: A good maintenance program will include periodic inspection of all Craft-Lag welds to ensure that any damaged welds are promptly repaired.

SECTION 5 - RETAINER BOLTING

Lagging applications where welding is not appropriate are candidates for bolting retainers in place. The only additional considerations are the extra attention needed to prevent the bolts from working loose and proper inspection to replace the pads before the belt starts to wear on the bolt heads.

STEP 1: Use 5/16-18, hex head, Grade 5 or better self-tapping or roll forming bolts (1/4" minimum shell thickness required). Be sure that sufficient thread engagement is provided and use some means of locking the bolts (self-locking threads, anaerobic adhesive, etc.). Retainers should be bolted using every other hole, including the first and last holes. Leave 1/2" extra retainer length past the edge of the rim to bend over rim and secure pads.

SECTION 6 - MISCELLANEOUS

- Occasionally, a combination of belt speed, belt construction, and system design will cause belt vibration as it passes over the Craft-Lag pads.

In these rare instances, it is possible to eliminate the vibration by installing Craft-Lag pads that are one-half the pulley face width in off-set rows on each half of the pulley. This can be done easily when installing without retainers, and with some additional difficulty if retainers are used.

- Powder actuated fasteners (Ram, Hilti, etc.,) are also alternate means for fastening retainers in place. Contact PPI for assistance if this fastening method is being considered.

- Inspect Craft-Lag pads and retainers (when used) periodically for wear and damage. The lagging pads should be replaced before they are worn enough to allow the belt to wear on the backing plate or retainers. Damaged retainers should be replaced immediately.

- After being in service for a period of years, Craft-Lag pads may accumulate enough corrosion to make removal difficult. In that case, drive a flat bar between the pulley shell and the backing plate from the end to pop the pad free of the retainers. Clean the pulley, install the new lagging pads, and pound the retainer lips down again. Inspect the retainers and replace any that may be damaged.

SECTION 7 - NON-STANDARD INSTALLATION

Non-standard installation procedures are used for Craft-Lag installation on:

- Magnetic pulleys
- Pulleys with odd diameters such as 12³/₄", 37", etc.
- Pulleys that are oversized or undersized by more than 1/4" from a "standard" even number diameter. These procedures will establish the number of rows of pads to be used as well as the quantities of double and single retainers required and the sequence to be used for their installation.

Non-standard installation involves the substitution of additional sets of single retainers for some of the double retainers that would normally be used.

This provides the proper coverage for types of pulleys described above. The calculations and procedures that are used allow this substitution to be done logically to achieve a balanced installation.

STEP 1: Enter the pulley diameter and face width in blanks A and B on page 5. Be sure that you have checked the actual pulley diameter to confirm that non-standard installation is really necessary.

STEP 2: Divide the pulley diameter (OD) by 2 and drop anything after the decimal point (INT) and enter this on line C. This is the number of pad rows needed.

STEP 3: (Multiply C by the face width B) + 6. This is the number of inches of Pads needed. Enter the result on line D.

STEP 4: Divide the OD by 24. Then add 0.8 for OD less than 20" or 1.5 for OD equal to or greater than 20". Drop anything beyond the decimal point. Subtract this number from C. Enter the result on line E.

STEP 5: If you have an even diameter or are within 1/4" of an even diameter, you do not need the correction in line F and can enter the result E on line G and skip to step 7.

STEP 6: Subtract 2 * C from the OD of the pulley. Then multiply the result by 3.14 (π). Drop anything beyond the decimal point. Compare this result to E, it should not be bigger than E. Enter the smaller of your result or E on line F.

STEP 7: Subtract F from E. This is the corrected (for odd diameters) number of double retainers needed. Enter this result on line G.

STEP 8: Subtract the number of doubles (G) from the number of pad rows (C). This is the number of pairs of single retainer rows needed.

STEP 9: Calculate the spacing between the pairs of single retainers. Take the OD and subtract twice the number of pad rows. Multiply this by PI (3.14) and divide by H (the number of pairs of single retainers). Round to the 1/16 of an inch.

STEP 10: Calculate the total inches of double retainers by multiplying G times B (divide by 72 and round up for # of retainers.

STEP 11: Calculate the total number of double retainers by dividing J by 72 and rounding up.

STEP 12: Calculate the total inches of single retainers by multiplying H times B and multiply by 2 (divide by 72 and round up for # of retainers).

STEP 13: Calculate the total number of single retainers by dividing L by 72 and rounding up.

STEP 14: Fill in Table 4 next. This chart is the guide to the proper sequence for installing the double and single retainers. Using the number of single retainer sets from Step 5, fill in the blanks at the proper points in column 3 to indicate where the singles should go. Space them as equally as possible around the pulley circumference. The balance of the retainers will be doubles, and the chart should be filled in accordingly.

WITHOUT RETAINERS

STEP 1-3: Are the same as 1-3 in the left column, using the table at the bottom left of page 5.

STEP 4: Multiply the OD (A) by 3.14 and enter the result on line E. This is the total circumference of the pulley.

STEP 5: Multiply the # of pad rows (C) by 5.375 and enter on line F. This is the amount of circumference covered by the Craft-Lag pads

STEP 6: Subtract F from E and enter on line G. This is amount of exposed circumference of the pulley.

STEP 7: Divide G by the # of pad rows (C) and enter on line H. This is the amount of space divided evenly between pad rows. Keep this spacing between pad rows so that the pads are evenly spaced around the pulley. The gap should not exceed 1.5"

Non-Standard Installation Worksheet		
Pulley Diameter	OD	A. _____ in
Face Width	FW	B. _____ in
Number of Pad Rows	= INT (OD ÷ 2)	C. _____ Pad Rows
Total Linear Inches of Pads Needed	= C x FW + 6	D. _____ in
Number of Rows of Double Retainers	= C - INT (OD / 24 + X)	E. _____ Rows Double (uncorrected)
Where X = 0.8 for OD less than 20, X = 1.5 for OD equal to or greater than 20"		
Correction (Doubles) for odd diameters	= INT (3.14 x (OD - 2 x C)	F. _____ Correction (< = E)
Corrected Number of Rows of Double Retainers	= E - F	G. _____ Rows Double (> = 0)
Number of Pairs (Rows) of Single Retainers	= C - G	H. _____ Pairs (Rows) Single
Single Retainer Spacing	= (3.14 x (OD - 2 x C) ÷ H	I. _____ (Round Down to 1/16")
Total Linear Inches of Double Retainers Needed	= G x B	J. _____ in
Number of Double Retainers	= J ÷ 72 (round up)	K. _____
Total Linear Inches of Single Retainers Needed	= 2 x H x B	L. _____
Number of Single Retainers	= L ÷ 72 (round up)	M. _____

Non-Standard Installation Worksheet		
Pulley Diameter	OD	A. _____ in
Face Width	FW	B. _____ in
Number of Pad Rows	= INT (OD ÷ 2)	C. _____ Pad Rows
Total Linear Inches of Pads Needed	= C x FW + 6	D. _____ in
Circumference of pulley	= 3.14 x A	E. _____
Circumference covered by Craft-Lag Pads	= 5.375 x C	F. _____
Exposed Circumference	= E - F	G. _____
Spacing between pads	= G ÷ C	H. _____



CORPORATE OFFICE • P.O. Box 287 • Pella, IA
50219800.247.1228 • 641.628.3115 • 641.628.3658 FAX