

WE KEEP IT MOVING

ENGINEERING & DIMENSIONS

BELT CONVEYOR IDLERS



TABLE OF CONTENTS

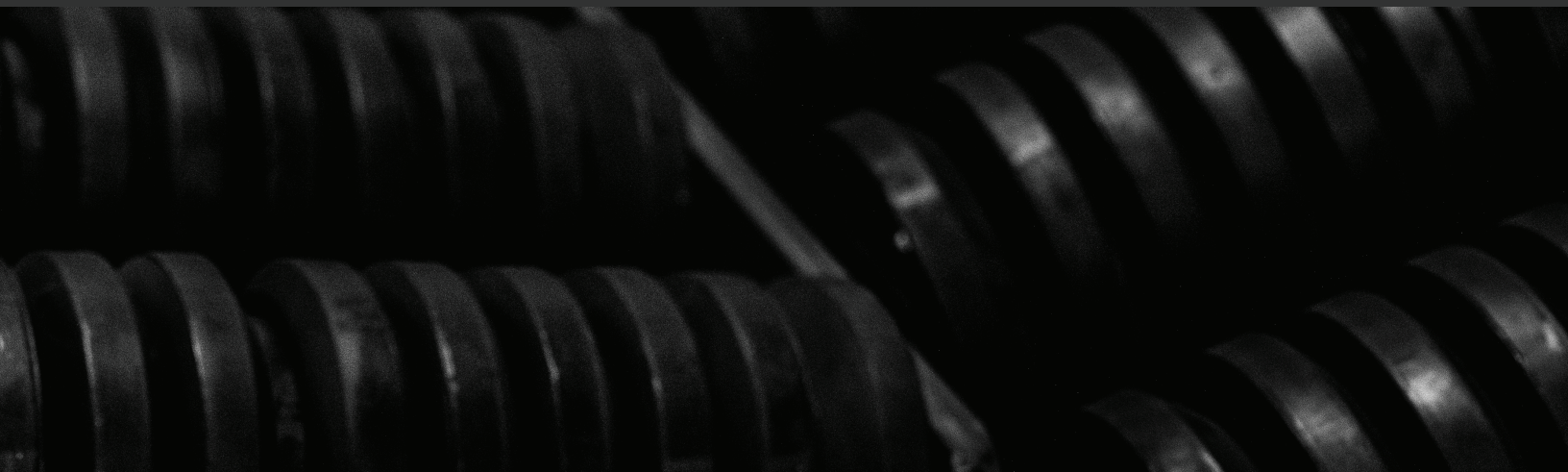

BELT CONVEYOR IDLERS



4 Idler Types & Applications

5 PPI Part Numbering

6-7 Features & Benefits

CEMA B SERIES

8-10 Equal Trougher & Impact Troughing Idler

11-12 Unequal Troughing, Flat & Rubber Disc

13-14 Return, Channel Inset Flat & Rubber Disc

15-16 Channel Inset Troughing and Return & Rubber Disc

17-18 Self Aligners (Troughing, Return & Flat)

CEMA C SERIES

19-21 Equal Impact Troughing Idler

22-23 Unequal Troughing, Flat & Rubber Disc

24-25 Return, V-Return & Rubber Disc

26-27 Channel Inset Troughing Idler and Return & Rubber Disc

28-29 Channel Inset Flat, Live Shaft & IVR and Rubber Disc

30-31 Self Aligners (Troughing, Return & Flat)

CEMA D SERIES

32-34 Equal & Impact Troughing Idler

35-36 Unequal Troughing, Flat & Rubber Disc

37-38 Return, V-Return & Rubber Disc

39-40 LiveShaft, Inverted V-Return & Rubber Disc

41-42 Self Aligners (Troughing, Return & Flat)

CEMA E SERIES

43-45 Equal & Impact Troughing Idler

46-47 Unequal Troughing, Flat & Rubber Disc

48-49 Return, V-Return & Rubber Disc

50-51 LiveShaft, Inverted V-Return & Rubber Disc

52-53 Self Aligners (Troughing & Return)

54-56 Mounting Details (Footpads & Brackets)

57 Guide Rollers

58 Stub Idlers

59-60 Specialty Products

61-62 Terms & Conditions

IDLER TYPES & APPLICATIONS

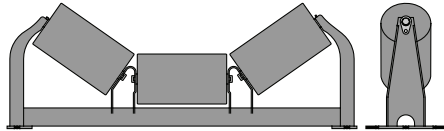

Equal Troughing Idlers support the belt and load in the transport section of the conveyor. Designed to meet or exceed the load limits established by the Conveyor Equipment Manufacturers Association (CEMA).

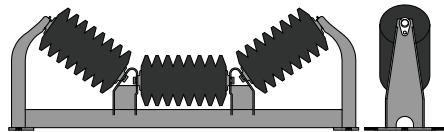

Impact Troughing Idlers are a special version of troughing idlers, providing a roll with cushioning rubber discs to lessen the belt damage due to impact from materials being loaded onto the belt. The frame is additionally reinforced to increase rigidity.

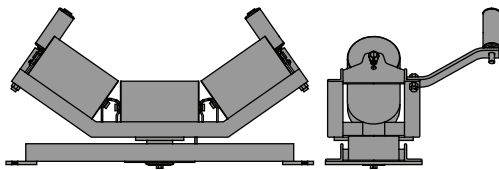

Self-Aligning Idlers, troughing, flat and return, assist in keeping the conveyor belt centered on the conveyor when temporary or transient conditions could result in belt misalignment.

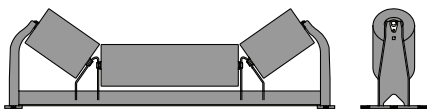

Unequal Troughing (Picking) Idlers are used to reduce the height to aid in magnetic separation, picking, sorting, or manual separation. The inclined roll ends turn up the belt to minimize spillage. Rubber disc rolls are also available. The load ratings are greatly reduced from standard troughing idlers because most of the weight is on the long center roll.

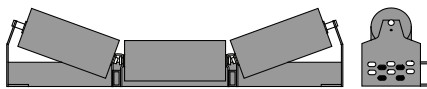

Channel Inset Troughing Idlers are attached to a channel conveyor or other vertical surface by side mounting. They are used in tight clearance areas requiring a low profile. Rubber disc rolls are also available. Designed to interchange with other major brands.



Flat Carrier Idler applications include picking, sorting, feeders, and package handling. Rubber disc rolls are also available. Load ratings are the same as return rolls and are greatly reduced from that of troughing idlers because of the long shaft length and having only two bearings.



Live Shaft Idlers with pillow block bearings provide an increased loading capacity. Available in solid and spaced rubber discs rolls and steel rolls.

Return Idlers support the belt during the return path and meet or exceed the CEMA load requirements.

Return and Flat Idler Cap (R, RRD, F, FRD, CIR, CIRRD, CIF, & CIFRD types) in B, C, D, and E series should not be used in a snub pulley type application. Shafting, bearings, and brackets may be overloaded in such applications leading to premature failure.

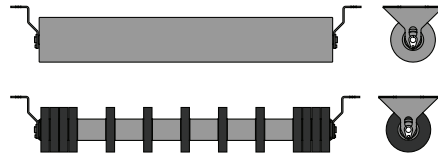

The following is a simplified conveyor used to illustrate basic belt conveyor components. Many variations of elevation, loading, discharge, idlers and idler spacing, pulleys, and accessories are possible.

Steel Tube used when materials are not sticky, corrosive, or abrasive.

Rubber Disc used when sticky, corrosive, or abrasive materials are present. Massed end discs are standard.

Covered Rolls used when very sticky or abrasive materials are present.

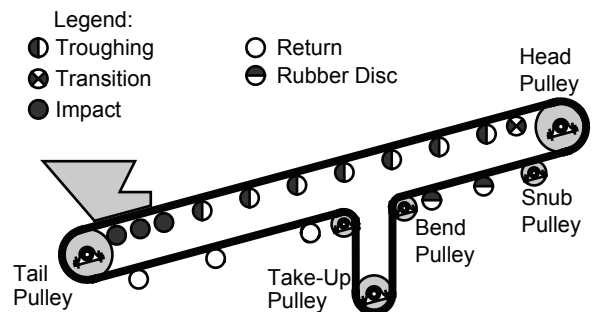

C5-35TE-36SB

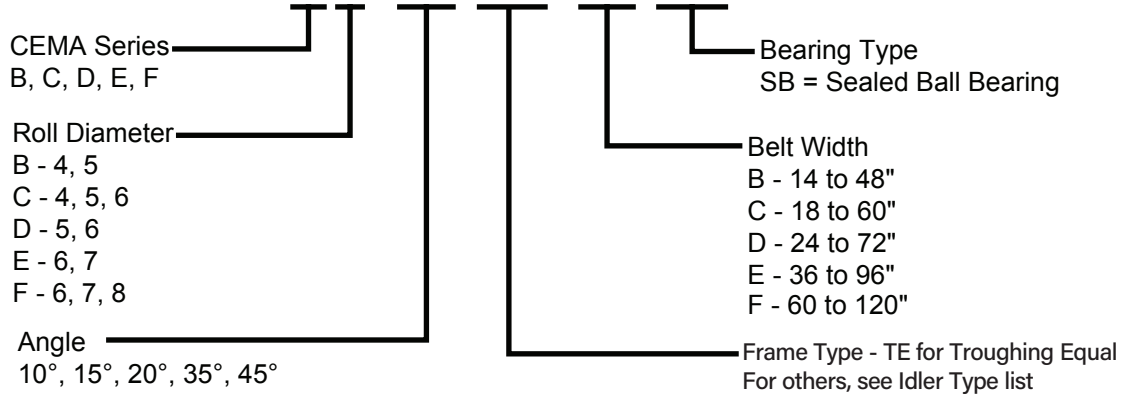

Note: Angle does not apply to flat or standard return idlers. Certain limitations apply, such as 10 for VR, 15 for IVR, and 20, 35 & 45 for TE.

IDLER TYPE LIST

TE	Troughing Equal
TEI	Troughing Equal Impact
TESA	Troughing Equal Self Aligner
TU	Troughing Unequal
TUI	Troughing Unequal Impact
CIT	Channel Inset Troughing
CITI	Channel Inset Troughing Impact
F	Flat
FRD	Flat Rubber Disc
FSA	Flat Self-Aligner
CIF	Channel Inset Flat
CIFRD	Channel Inset Flat Rubber Disc
R	Return
RRD	Return Rubber Disc
RSA	Return Self-Aligner
RRDSA	Return Rubber Disc Self-Aligner
CIR	Channel Inset Return

CIRRD	Channel Inset Return Rubber Disc
VR	V-Return
VRI	V-Return Impact
IVR	Inverted V-Return
IVRI	Inverted V-Return Impact
LSI	Live Shaft Impact
LSRRD	Live Shaft Return Rubber Disc
LSR	Live Shaft Return (Steel)
TIS	Troughing Impact System
TISZ	Troughing Impact System - 2 Foot
EZI	EZ Slider with Impact Rolls
TET	Troughing Equal Transition
GRT	Guide Roll Troughing
GRF	Guide Roll Flat
GRR	Guide Roll Return
SADxCSR	Smart Roll Clean Side Return

For other types, consult your local PPI distributor and/or representative.

For replacement rolls, clips, brackets, etc. (as well as special brackets) see the PPI Idler Replacement Parts catalog, available on our website at www.ppi-global.com.

Figures used in this catalog are for dimensional reference only. Some variation may occur from the illustrations.

IDLER FEATURES & BENEFITS

FEATURES

- Designed and manufactured for a long, trouble-free life
- Maintenance-free, high-quality sealed ball bearings
- Conforms to CEMA standards for dimensions and meets or exceeds series load ratings

HIGHLIGHTS

- | | | | |
|---|---|----|--|
| 1 | Full tube thickness at the end bell weld extends wear life | 7 | Long-lasting contact seal protected from the environment |
| 2 | Full thickness tubing for the length of the roll with additional wall thickness options available | 8 | High-quality ball bearing with manufacturer's contact seals and grease |
| 3 | Low Total Indicator Run-out (TIR) or run-out | 9 | Wide, heavy-duty formed end brackets |
| 4 | Large diameter stationary outer seal | 10 | Tough foot pads for a solid base |
| 5 | Highly-effective centrifugal seal | 11 | Wide center brackets for heavy loads |
| 6 | Effective radial and labyrinth seals | 12 | Minimal roll gaps |

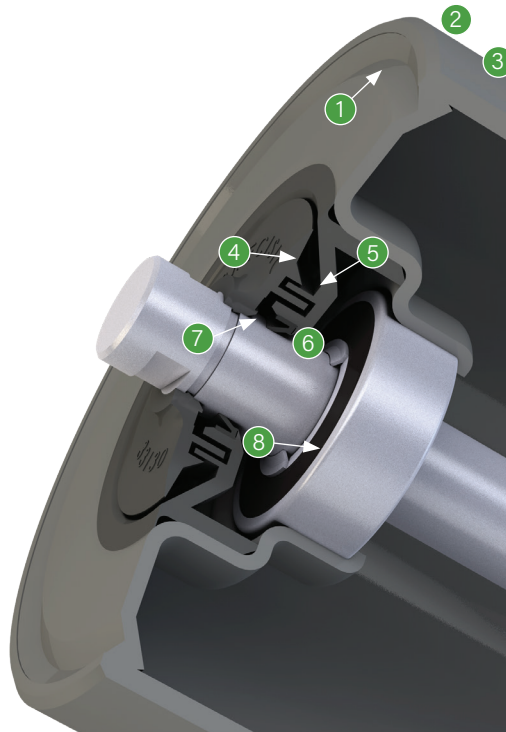

CEMA B, D, E, E+ & F

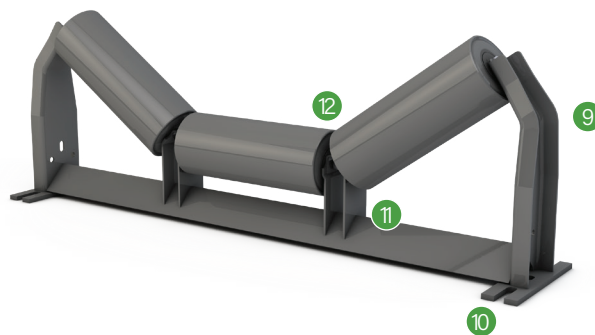

IDLER SPECIFICATIONS

CEMA B

6203 - 17mm (0.67in)
17mm (0.67in)

BELT WIDTH	TROUGHING ANGLE			RETURN & FLAT	UNEQUAL	
	20°	35°	45°		20°	35°
18	410	410	410	220		
24	410	410	410	190	390	410
30	410	410	410	165	220	390
36	410	410	369	155	190	220
42	390	363	351	140	165	220
48	380	353	342	125	155	190

CEMA C

P6204 - 19mm (0.75in) / 19mm (0.75in)

BELT WIDTH	TROUGHING ANGLE			RETURN & FLAT	TWO-ROLL V-RETURNS	UNEQUAL (Picking)	LIVE SHAFT
	20°	35°	45°				
18	900	900	900	475	500	475	1,200
24	900	900	900	325	500	475	1,200
30	900	900	900	250	500	475	1,200
36	900	837	810	200	500	325	1,200
42	850	791	765	150	500	250	1,100
48	800	744	720	125	500	200	1,000
54	750	698	675	CEMA D	500	150	875
60	700	650	630	CEMA D	500	125	780
66	-	-	-	CEMA D	500	-	-

CEMA D

6305 - 25mm (0.98in) / 25.4mm (1.00in)

18	1,200	1,200	1,200	600	850	600	1,400
24	1,200	1,200	1,200	600	850	600	1,400
30	1,200	1,200	1,200	600	850	600	1,400
36	1,200	1,200	1,200	600	850	600	1,400
42	1,200	1,200	1,200	500	850	600	1,400
48	1,200	1,200	1,200	425	850	530	1,275
54	1,200	1,116	1,080	375	850	440	1,150
60	1,150	1,070	1,035	280	850	400	1,000
66	-	-	-	215	850	-	-
72	1,050	977	945	155	850	280	850
78	-	-	-	125	850	-	-

CEMA E

6307 - 35mm (1.38in) / 35.5mm (1.4in)

36	1,800	1,800	1,800	1,000	1,300	1,260	2,100
42	1,800	1,800	1,800	1,000	1,300	1,200	2,100
48	1,800	1,800	1,800	1,000	1,300	1,000	2,100
54	1,800	1,800	1,800	925	1,300	1,000	2,100
60	1,800	1,800	1,800	850	1,300	1,000	2,100
66	1,800	1,800	1,800	775	1,300	1,000	2,100
72	1,800	1,800	1,800	700	1,300	925	2,100
78	-	-	-	625	1,300	-	2,100
84	1,800	1,674	1,620	550	1,300	775	1,825
90	-	-	-	475	1,300	-	-
96	1,750	1,628	1,575	400	1,300	625	-
102	-	-	-	250	1,300	-	-

PPIE PLUS

6308 - 40mm (1.57in) / 43mm (1.69in)

36	2,100	2,100	2,100	1,200	1,600	1,495	2,100
42	2,100	2,100	2,100	1,200	1,600	1,440	2,100
48	2,100	2,100	2,100	1,200	1,600	1,200	2,100
54	2,100	2,100	2,100	1,110	1,600	1,200	2,100
60	2,100	2,100	2,100	1,020	1,600	1,200	2,100
66	2,100	2,100	2,100	930	1,600	1,155	2,100
72	2,095	2,095	2,095	840	1,600	1,110	2,100
78	2,095	2,095	2,095	720	1,600	980	2,100
84	2,090	2,090	2,090	605	1,600	850	1,825
90	2,085	2,085	2,085	520	1,600	795	-
96	2,080	2,080	2,080	440	1,600	680	-
102	2,075	2,075	2,075	275	1,600	510	-

CEMA F

6310 - 50mm (1.97in) / 51mm (2.00in)

BELT WIDTH	TROUGHING ANGLE			RETURN & FLAT	TWO-ROLL V-RETURN*	UNEQUAL (Picking)
	20°	35°	45°			
60	3,000	3,000	3,000	1,500	2,100	2,000
66	3,000	3,000	3,000	1,350	2,100	2,000
72	3,000	3,000	3,000	1,200	2,100	1,900
78	3,000	3,000	3,000	1,050	2,100	1,700
84	3,000	3,000	3,000	900	2,100	1,500
90	3,000	3,000	3,000	750	2,100	1,350
96	2,800	2,800	2,800	600	2,100	1,200
102	2,800	2,800	2,800	-	2,100	1,050
108	2,800	2,800	2,800	-	2,100	900
114	2,800	2,800	2,800	-	2,100	750
120	2,800	2,800	2,800	-	2,100	600
126	-	-	-	-	2,100	-

CEMA B CLASS IDLERS

CEMA B CLASS IDLERS PRODUCT OFFERINGS

- Equal Troughing Idler
- Equal Impact Troughing Idler
- Unequal Troughing Idler
- Unequal Impact Troughing Idler
- Flat Carrier
- Impact Flat Carrier
- Return Roller
- Return Rubber Disc
- Channel Inset Flat Carrier
- Channel Inset Flat Rubber Disc Carrier
- Channel Inset Troughing Idler
- Channel Inset Return Roller
- Channel Inset Impact Troughing Idler
- Channel Inset Impact Return Roller
- Self-Aligner Troughing Idler
- Self-Aligner Return Roller
- Self-Aligner Flat Roller
- Additional Configurations Available



CEMA B LOAD RATINGS

BELT WIDTH	TROUGHING ANGLE			RETURN & FLAT	UNEQUAL	
	20°	35°	45°		20°	35°
18	410	410	410	220		
24	410	410	410	190	390	410
30	410	410	410	165	220	390
36	410	410	369	155	190	220
42	390	363	351	140	165	220
48	380	353	342	125	155	190

CEMA B EQUAL TROUGHING IDLER

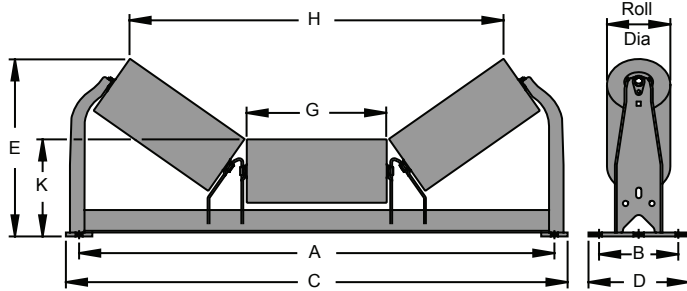

Belt Width	Standard Dimensions				
	A	B	C	D	G*
14	23	6	25	8	5 7/16
16	25	6	27	8	6 3/4
18	27	6	29	8	6 3/4
20	29	6	31	8	7 5/8
24	33	6	35	8	8 15/16
30	39	6	41	8	11 1/8
36	45	6	47	8	13 1/4
42	51	7 1/2	53 1/2	9 1/2	15 7/16
48	57	7 1/2	59 1/2	9 1/2	17 5/8

20° EQUAL TROUGHING IDLER

Belt Width	4" Roll Diameter					5" Roll Diameter				
	Part Number	E	H	K	WT	Part Number	E	H	K	WT
14	B4-20TE-14SB	9 1/16	16 15/16	7	25	B5-20TE-14SB	9 1/2	16 9/16	7 1/2	28
16	B4-20TE-16SB	9 1/16	18 1/4	7	26	B5-20TE-16SB	9 1/2	17 7/8	7 1/2	29
18	B4-20TE-18SB	9 7/16	20 11/16	7	28	B5-20TE-18SB	9 15/16	20 3/8	7 1/2	32
20	B4-20TE-20SB	9 13/16	23 1/4	7	30	B5-20TE-20SB	10 1/4	22 7/8	7 1/2	34
24	B4-20TE-24SB	10 1/4	26 15/16	7	33	B5-20TE-24SB	10 11/16	26 11/16	7 1/2	38
30	B4-20TE-30SB	10 15/16	33 5/16	7	39	B5-20TE-30SB	11 7/16	32 15/16	7 1/2	43
36	B4-20TE-36SB	11 11/16	39 7/16	7	44	B5-20TE-36SB	12 3/16	39 1/16	7 1/2	49
42	B4-20TE-42SB	12 15/16	45 3/4	7 1/2	54	B5-20TE-42SB	13 7/16	45 3/8	8	60
48	B4-20TE-48SB	13 11/16	52 1/16	7 1/2	60	B5-20TE-48SB	14 3/16	51 11/16	8	66

35° EQUAL TROUGHING IDLER

Belt Width	4" Roll Diameter					5" Roll Diameter				
	Part Number	E	H	K	WT	Part Number	E	H	K	WT
14	B4-35TE-14SB	10 1/4	15 1/2	7	26	B5-35TE-14SB	10 11/16	14 7/8	7 1/2	29
16	B4-35TE-16SB	10 1/4	16 13/16	7	27	B5-35TE-16SB	10 11/16	16 1/4	7 1/2	30
18	B4-35TE-18SB	10 15/16	18 15/16	7	29	B5-35TE-18SB	11 3/8	18 3/8	7 1/2	32
20	B4-35TE-20SB	11 1/2	21 1/4	7	31	B5-35TE-20SB	11 15/16	20 11/16	7 1/2	35
24	B4-35TE-24SB	12 1/4	24 11/16	7	34	B5-35TE-24SB	12 5/8	24 1/8	7 1/2	39
30	B4-35TE-30SB	13 1/2	30 1/2	7	40	B5-35TE-30SB	13 15/16	29 7/8	7 1/2	45
36	B4-35TE-36SB	14 11/16	36 1/8	7	45	B5-35TE-36SB	15 1/8	35 1/2	7 1/2	51
42	B4-35TE-42SB	16 7/16	41 7/8	7 1/2	56	B5-35TE-42SB	16 7/8	41 1/4	8	62
48	B4-35TE-48SB	17 11/16	47 5/8	7 1/2	62	B5-35TE-48SB	18 1/8	47 1/16	8	69

45° EQUAL TROUGHING IDLER

Belt Width	4" Roll Diameter					5" Roll Diameter				
	Part Number	E	H	K	WT	Part Number	E	H	K	WT
14	B4-45TE-14SB	11 3/16	14 1/8	7	27	B5-45TE-14SB	11 1/2	13 7/16	7 1/2	30
16	B4-45TE-16SB	11 3/16	15 7/16	7	28	B5-45TE-16SB	11 1/2	14 11/16	7 1/2	31
18	B4-45TE-18SB	12 1/8	17 1/4	7	31	B5-45TE-18SB	12 7/16	16 9/16	7 1/2	34
20	B4-45TE-20SB	12 11/16	19 3/8	7	33	B5-45TE-20SB	13 1/16	18 11/16	7 1/2	36
24	B4-45TE-24SB	13 5/8	22 9/16	7	35	B5-45TE-24SB	13 15/16	21 7/8	7 1/2	40
30	B4-45TE-30SB	15 3/16	27 11/16	7	41	B5-45TE-30SB	15 9/16	27 1/8	7 1/2	46
36	B4-45TE-36SB	16 11/16	32 15/16	7	47	B5-45TE-36SB	17 1/16	32 1/4	7 1/2	53
42	B4-45TE-42SB	18 11/16	38 1/4	7 1/2	63	B5-45TE-42SB	19 1/16	37 9/16	8	69
48	B4-45TE-48SB	20 1/4	43 9/16	7 1/2	68	B5-45TE-48SB	20 5/8	42 13/16	8	75

*16" belt width G=6 3/4" for center roll and 5 7/16" for wing roll.

CEMA B EQUAL IMPACT TROUGHING IDLER

Belt Width	Standard Dimensions				
	A	B	C	D	G*
14	23	6	25	8	3 5/16
16	25	6	27	8	4 5/8
18	27	6	29	8	4 5/8
20	29	6	31	8	5 1/2
24	33	6	35	8	6 13/16
30	39	6	41	8	9
36	45	6	47	8	11 1/8
42	51	7 1/2	53 1/2	9 1/2	13 5/16
48	57	7 1/2	59 1/2	9 1/2	15 1/2

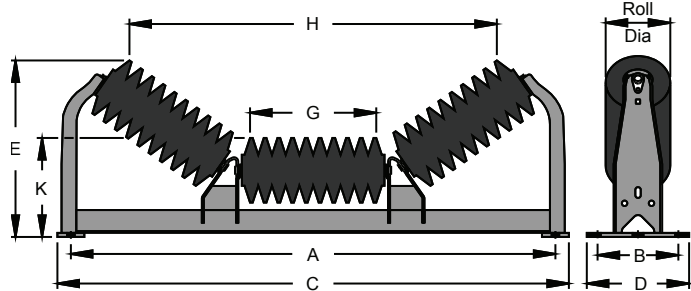

20° EQUAL IMPACT TROUGHING IDLER

Belt Width	4" Roll Diameter					5" Roll Diameter				
	Part Number	E	H	K	WT	Part Number	E	H	K	WT
14	B4-20TEI-14SB	8 11/16	14 15/16	7	31	B5-20TEI-14SB	9 1/8	14 9/16	7 1/2	36
16	B4-20TEI-16SB	8 11/16	16 1/4	7	35	B5-20TEI-16SB	9 1/8	15 7/8	7 1/2	40
18	B4-20TEI-18SB	9 1/16	18 11/16	7	37	B5-20TEI-18SB	9 9/16	18 3/8	7 1/2	43
20	B4-20TEI-20SB	9 7/16	21 1/4	7	41	B5-20TEI-20SB	9 7/8	20 7/8	7 1/2	49
24	B4-20TEI-24SB	9 7/8	24 15/16	7	47	B5-20TEI-24SB	10 5/16	24 11/16	7 1/2	56
30	B4-20TEI-30SB	10 9/16	31 5/16	7	56	B5-20TEI-30SB	11 1/16	30 15/16	7 1/2	65
36	B4-20TEI-36SB	11 5/16	37 7/16	7	66	B5-20TEI-36SB	11 13/16	37 1/16	7 1/2	77
42	B4-20TEI-42SB	12 9/16	43 3/4	7 1/2	81	B5-20TEI-42SB	13 1/16	43 3/8	8	95
48	B4-20TEI-48SB	13 5/16	50 1/16	7 1/2	92	B5-20TEI-48SB	13 13/16	49 11/16	8	107

35° EQUAL IMPACT TROUGHING IDLER

Belt Width	4" Roll Diameter					5" Roll Diameter				
	Part Number	E	H	K	WT	Part Number	E	H	K	WT
14	B4-35TEI-14SB	9 5/8	13 3/4	7	32	B5-35TEI-14SB	10 1/16	13 1/8	7 1/2	37
16	B4-35TEI-16SB	9 5/8	15 1/16	7	36	B5-35TEI-16SB	10 1/16	14 1/2	7 1/2	41
18	B4-35TEI-18SB	10 5/16	17 3/16	7	38	B5-35TEI-18SB	10 3/4	16 5/8	7 1/2	44
20	B4-35TEI-20SB	10 7/8	19 1/2	7	42	B5-35TEI-20SB	11 5/16	18 15/16	7 1/2	50
24	B4-35TEI-24SB	11 5/8	22 15/16	7	48	B5-35TEI-24SB	12	22 3/8	7 1/2	57
30	B4-35TEI-30SB	12 7/8	28 3/4	7	60	B5-35TEI-30SB	13 5/16	28 1/8	7 1/2	67
36	B4-35TEI-36SB	14 1/16	34 3/8	7	68	B5-35TEI-36SB	14 1/2	33 3/4	7 1/2	79
42	B4-35TEI-42SB	15 13/16	40 1/8	7 1/2	83	B5-35TEI-42SB	16 1/4	39 1/2	8	96
48	B4-35TEI-48SB	17 1/16	45 7/8	7 1/2	95	B5-35TEI-48SB	17 1/2	45 5/16	8	109

45° EQUAL IMPACT TROUGHING IDLER

Belt Width	4" Roll Diameter					5" Roll Diameter				
	Part Number	E	H	K	WT	Part Number	E	H	K	WT
14	B4-45TEI-14SB	10 7/16	12 5/8	7	33	B5-45TEI-14SB	10 3/4	11 15/16	7 1/2	38
16	B4-45TEI-16SB	10 7/16	13 15/16	7	37	B5-45TEI-16SB	10 3/4	13 3/16	7 1/2	42
18	B4-45TEI-18SB	11 3/8	15 3/4	7	39	B5-45TEI-18SB	11 11/16	15 1/16	7 1/2	45
20	B4-45TEI-20SB	11 15/16	17 7/8	7	43	B5-45TEI-20SB	12 5/16	17 3/16	7 1/2	51
24	B4-45TEI-24SB	12 7/8	21 1/16	7	49	B5-45TEI-24SB	13 3/16	20 3/8	7 1/2	58
30	B4-45TEI-30SB	14 7/16	26 3/16	7	58	B5-45TEI-30SB	14 13/16	25 5/8	7 1/2	68
36	B4-45TEI-36SB	15 15/16	31 7/16	7	70	B5-45TEI-36SB	16 5/16	30 3/4	7 1/2	81
42	B4-45TEI-42SB	17 15/16	36 3/4	7 1/2	90	B5-45TEI-42SB	18 5/16	36 1/16	8	103
48	B4-45TEI-48SB	19 1/2	42 1/16	7 1/2	102	B5-45TEI-48SB	19 7/8	41 5/16	8	117

*16" belt width G=4 5/8" for center roll and 3 5/16" for wing roll.

CEMA B UNEQUAL TROUGHING & FLAT CARRIER

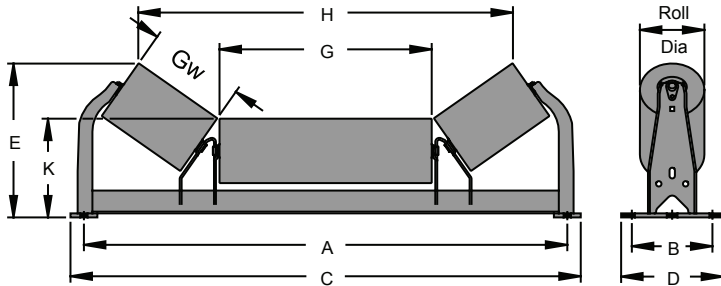

Belt Width	Standard Dimensions			
	A	B	C	D
24	33	6	35	8
30	39	6	41	8
36	45	6	47	8
42	51	7 1/2	53 1/2	9 1/2
48	57	7 1/2	59 1/2	9 1/2

20° UNEQUAL TROUGHING IDLER

Belt Width	4" Roll Diameter					5" Roll Diameter					G	Gw
	Part Number	E	H	K	WT	Part Number	E	H	K	WT		
24	B4-20TU-24SB	9 1/16	26 15/16	7	33	B5-20TU-24SB	9 7/16	26 9/16	7 1/2	37	15 7/16	5 7/16
30	B4-20TU-30SB	9 1/16	32 7/8	7	38	B5-20TU-30SB	9 7/16	32 1/2	7 1/2	43	21 3/8	5 7/16
36	B4-20TU-36SB	9 1/16	38 7/8	7	43	B5-20TU-36SB	9 7/16	38 1/2	7 1/2	48	27 3/8	5 7/16
42	B4-20TU-42SB	9 9/16	44 7/8	7 1/2	53	B5-20TU-42SB	9 15/16	44 1/2	8	59	33 3/8	5 7/16
48	B4-20TU-48SB	9 9/16	50 7/8	7 1/2	58	B5-20TU-48SB	9 15/16	50 1/2	8	64	39 3/8	5 7/16

35° UNEQUAL TROUGHING IDLER

Belt Width	4" Roll Diameter					5" Roll Diameter					G	Gw
	Part Number	E	H	K	WT	Part Number	E	H	K	WT		
24	B4-35TU-24SB	11	25 7/16	7	35	B5-35TU-24SB	11 3/8	24 7/8	7 1/2	39	13 1/4	6 3/4
30	B4-35TU-30SB	12 1/4	31 1/4	7	40	B5-35TU-30SB	12 5/8	30 11/16	7 1/2	45	15 7/16	8 15/16
36	B4-35TU-36SB	12 1/4	37 1/8	7	45	B5-35TU-36SB	12 5/8	36 9/16	7 1/2	50	21 3/8	8 15/16
42	B4-35TU-42SB	14	40 3/16	7 1/2	56	B5-35TU-42SB	14 3/8	40 3/4	8	64	21 3/8	11 1/8
48	B4-35TU-48SB	14	46 3/4	7 1/2	63	B5-35TU-48SB	14 3/8	46	8	70	27 3/8	11 1/8

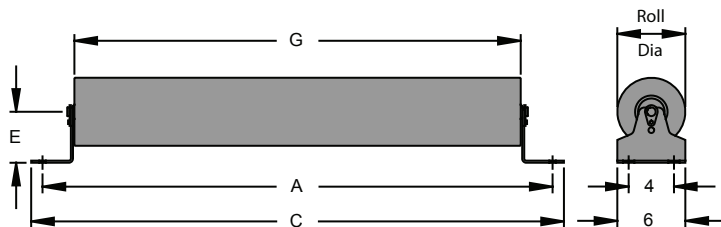

FLAT CARRIER

Belt Width	4" Roll Diameter				5" Roll Diameter				Standard Dimensions		
	E=4 1/2"		E=1 1/2"		E=4 1/2"		E=1 1/2"		A	C	G
	Part Number	WT	Part Number	WT	Part Number	WT	Part Number	WT			
14	B4-F-14SB	17	B4-F-14SB-1	16	B5-F-14SB	19	B5-F-14SB-1	18	23	25	17 3/8
16	B4-F-16SB	18	B4-F-16SB-1	17	B5-F-16SB	20	B5-F-16SB-1	19	25	27	19 3/8
18	B4-F-18SB	19	B4-F-18SB-1	18	B5-F-18SB	21	B5-F-18SB-1	20	27	29	21 3/8
20	B4-F-20SB	20	B4-F-20SB-1	19	B5-F-20SB	23	B5-F-20SB-1	22	29	31	23 3/8
24	B4-F-24SB	22	B4-F-24SB-1	21	B5-F-24SB	25	B5-F-24SB-1	24	33	35	27 3/8
30	B4-F-30SB	25	B4-F-30SB-1	24	B5-F-30SB	29	B5-F-30SB-1	28	39	41	33 3/8
36	B4-F-36SB	28	B4-F-36SB-1	27	B5-F-36SB	32	B5-F-36SB-1	31	45	47	39 3/8
42	B4-F-42SB	31	B4-F-42SB-1	30	B5-F-42SB	36	B5-F-42SB-1	35	51	53	45 3/8
48	B4-F-48SB	34	B4-F-48SB-1	33	B5-F-48SB	39	B5-F-48SB-1	38	57	59	51 3/8

CEMA B UNEQUAL IMPACT TROUGHING & FLAT CARRIER

Belt Width	Standard Dimensions			
	A	B	C	D
24	33	6	35	8
30	39	6	41	8
36	45	6	47	8
42	51	7 1/2	53 1/2	9 1/2
48	57	7 1/2	59 1/2	9 1/2

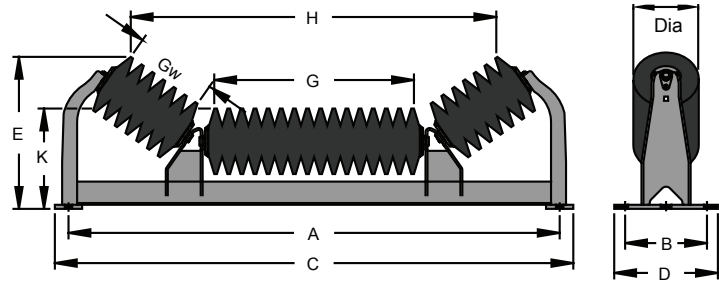

20° UNEQUAL TROUGHING

Belt Width	4" Roll Diameter					5" Roll Diameter					G	Gw
	Part Number	E	H	K	WT	Part Number	E	H	K	WT		
24	B4-20TUI-24SB	8 11/16	24 15/16	7	46	B5-20TUI-24SB	9 1/16	24 9/16	7 1/2	54	13 5/16	3 5/16
30	B4-20TUI-30SB	8 11/16	30 7/8	7	55	B5-20TUI-30SB	9 1/16	30 1/2	7 1/2	61	19 1/4	3 5/16
36	B4-20TUI-36SB	8 11/16	36 7/8	7	62	B5-20TUI-36SB	9 1/16	36 1/2	7 1/2	68	25 1/4	3 5/16
42	B4-20TUI-42SB	9 3/16	42 7/8	7 1/2	75	B5-20TUI-42SB	9 9/16	42 1/2	8	80	31 1/4	3 5/16
48	B4-20TUI-48SB	9 3/16	48 7/8	7 1/2	85	B5-20TUI-48SB	9 9/16	48 1/2	8	99	37 1/4	3 5/16

35° UNEQUAL TROUGHING

Belt Width	4" Roll Diameter					5" Roll Diameter					G	Gw
	Part Number	E	H	K	WT	Part Number	E	H	K	WT		
24	B4-35TUI-24SB	10 3/8	23 11/16	7	47	B5-35TUI-24SB	10 3/4	23 1/8	7 1/2	51	11 1/8	4 5/8
30	B4-35TUI-30SB	11 5/8	29 1/2	7	58	B5-35TUI-30SB	12	28 15/16	7 1/2	63	13 5/16	6 13/16
36	B4-35TUI-36SB	11 5/8	35 3/8	7	66	B5-35TUI-36SB	12	34 13/16	7 1/2	70	19 1/4	6 13/16
42	B4-35TUI-42SB	13 3/8	38 7/16	7 1/2	79	B5-35TUI-42SB	13 3/4	39	8	91	19 1/4	9
48	B4-35TUI-48SB	13 3/8	45	7 1/2	93	B5-35TUI-48SB	13 3/4	44 1/4	8	99	25 1/4	9

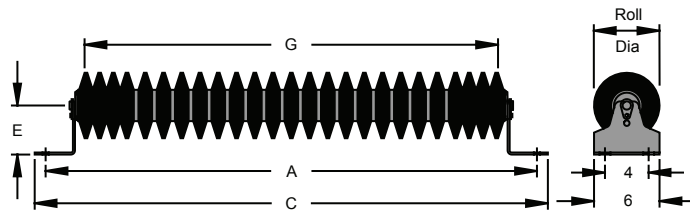

FLAT CARRIER RUBBER DISC

Belt Width	4" Roll Diameter				5" Roll Diameter				Standard Dimensions		
	E=4 1/2"		E=1 1/2"		E=4 1/2"		E=1 1/2"		A	C	G
	Part Number	WT	Part Number	WT	Part Number	WT	Part Number	WT			
14	B4-FRD-14SB	20	B4-FRD-14SB-1	19	B5-FRD-14SB	27	B5-FRD-14SB-1	26	23	25	15 7/8
16	B4-FRD-16SB	22	B4-FRD-16SB-1	21	B5-FRD-16SB	29	B5-FRD-16SB-1	28	25	27	17 7/8
18	B4-FRD-18SB	23	B4-FRD-18SB-1	22	B5-FRD-18SB	31	B5-FRD-18SB-1	30	27	29	19 7/8
20	B4-FRD-20SB	25	B4-FRD-20SB-1	24	B5-FRD-20SB	33	B5-FRD-20SB-1	32	29	31	21 7/8
24	B4-FRD-24SB	28	B4-FRD-24SB-1	27	B5-FRD-24SB	36	B5-FRD-24SB-1	35	33	35	25 7/8
30	B4-FRD-30SB	33	B4-FRD-30SB-1	32	B5-FRD-30SB	43	B5-FRD-30SB-1	42	39	41	31 7/8
36	B4-FRD-36SB	39	B4-FRD-36SB-1	38	B5-FRD-36SB	50	B5-FRD-36SB-1	49	45	47	37 7/8
42	B4-FRD-42SB	44	B4-FRD-42SB-1	43	B5-FRD-42SB	57	B5-FRD-42SB-1	56	51	53	43 7/8
48	B4-FRD-48SB	50	B4-FRD-48SB-1	49	B5-FRD-48SB	63	B5-FRD-48SB-1	62	57	59	49 7/8

CEMA B RETURN & CHANNEL INSET FLAT CARRIER

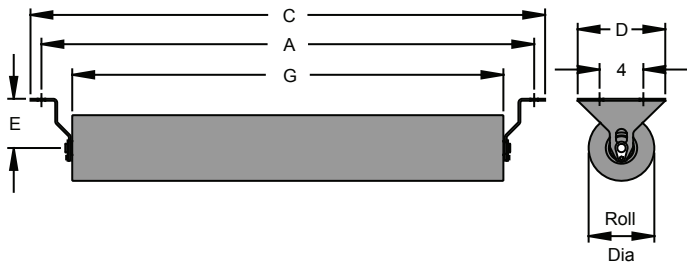

RETURN

Belt Width	4" Roll Diameter						5" Roll Diameter						Standard Dimensions		
	E=4½"			E=1½"			E=4½"			E=1½"					
	Part Number	D	WT	Part Number	D	WT	Part Number	D	WT	Part Number	D	WT	A	C	G
14	B4-R-14SB	8	14	B4-R-14SB-1	6	13	B5-R-14SB	8	17	B5-R-14SB-1	6	16	23	25	17 3/8
16	B4-R-16SB	8	15	B4-R-16SB-1	6	14	B5-R-16SB	8	18	B5-R-16SB-1	6	17	25	27	19 3/8
18	B4-R-18SB	8	16	B4-R-18SB-1	6	15	B5-R-18SB	8	19	B5-R-18SB-1	6	18	27	29	21 3/8
20	B4-R-20SB	8	17	B4-R-20SB-1	6	16	B5-R-20SB	8	20	B5-R-20SB-1	6	19	29	31	23 3/8
24	B4-R-24SB	8	19	B4-R-24SB-1	6	18	B5-R-24SB	8	23	B5-R-24SB-1	6	22	33	35	27 3/8
30	B4-R-30SB	8	22	B4-R-30SB-1	6	21	B5-R-30SB	8	26	B5-R-30SB-1	6	25	39	41	33 3/8
36	B4-R-36SB	8	25	B4-R-36SB-1	6	24	B5-R-36SB	8	30	B5-R-36SB-1	6	29	45	47	39 3/8
42	B4-R-42SB	8	28	B4-R-42SB-1	6	27	B5-R-42SB	8	33	B5-R-42SB-1	6	32	51	53	45 3/8
48	B4-R-48SB	8	31	B4-R-48SB-1	6	30	B5-R-48SB	8	37	B5-R-48SB-1	6	36	57	59	51 3/8

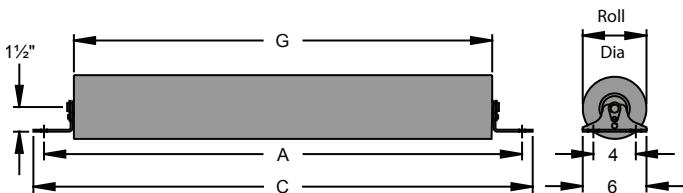

CHANNEL INSET FLAT CARRIER

Belt Width	4" Roll Diameter		5" Roll Diameter		Standard Dimensions		
	Part Number	WT	Part Number	WT	A	C	G
14	B4-CIF-14SB	14	B5-CIF-14SB	16	22	24	16 1/2
16	B4-CIF-16SB	15	B5-CIF-16SB	17	24	26	18 1/2
18	B4-CIF-18SB	16	B5-CIF-18SB	18	26	28	20 1/2
20	B4-CIF-20SB	17	B5-CIF-20SB	19	28	30	22 1/2
24	B4-CIF-24SB	19	B5-CIF-24SB	22	32	34	26 1/2
30	B4-CIF-30SB	22	B5-CIF-30SB	26	38	40	32 1/2
36	B4-CIF-36SB	25	B5-CIF-36SB	29	44	46	38 1/2
42	B4-CIF-42SB	27	B5-CIF-42SB	33	50	52	44 1/2
48	B4-CIF-48SB	31	B5-CIF-48SB	36	56	58	50 1/2

CEMA B RETURN RUBBER DISC & CHANNEL INSET FLAT IMPACT

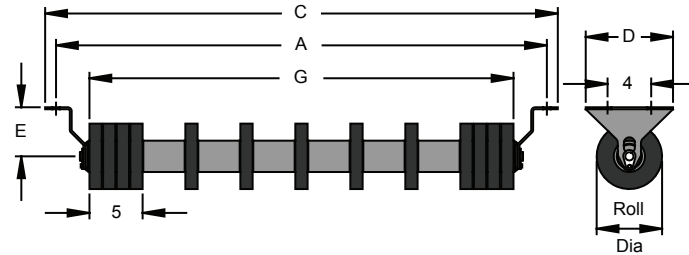

RETURN RUBBER DISC

Belt Width	4" Roll Diameter						5" Roll Diameter						Standard Dimensions		
	E=4½"			E=1½"			E=4½"			E=1½"					
	Part Number	D	WT	Part Number	D	WT	Part Number	D	WT	Part Number	D	WT	A	C	G
14	B4-RRD-14SB	8	18	B4-RRD-14SB-1	6	17	B5-RRD-14SB	8	22	B5-RRD-14SB-1	6	21	23	25	16 5/8
16	B4-RRD-16SB	8	20	B4-RRD-16SB-1	6	19	B5-RRD-16SB	8	24	B5-RRD-16SB-1	6	23	25	27	18 5/8
18	B4-RRD-18SB	8	21	B4-RRD-18SB-1	6	20	B5-RRD-18SB	8	25	B5-RRD-18SB-1	6	24	27	29	20 5/8
20	B4-RRD-20SB	8	22	B4-RRD-20SB-1	6	21	B5-RRD-20SB	8	26	B5-RRD-20SB-1	6	25	29	31	22 5/8
24	B4-RRD-24SB	8	24	B4-RRD-24SB-1	6	23	B5-RRD-24SB	8	29	B5-RRD-24SB-1	6	28	33	35	26 5/8
30	B4-RRD-30SB	8	28	B4-RRD-30SB-1	6	27	B5-RRD-30SB	8	33	B5-RRD-30SB-1	6	32	39	41	32 5/8
36	B4-RRD-36SB	8	33	B4-RRD-36SB-1	6	32	B5-RRD-36SB	8	37	B5-RRD-36SB-1	6	36	45	47	38 5/8
42	B4-RRD-42SB	8	35	B4-RRD-42SB-1	6	34	B5-RRD-42SB	8	41	B5-RRD-42SB-1	6	40	51	53	44 5/8
48	B4-RRD-48SB	8	39	B4-RRD-48SB-1	6	38	B5-RRD-48SB	8	45	B5-RRD-48SB-1	6	44	57	59	50 5/8

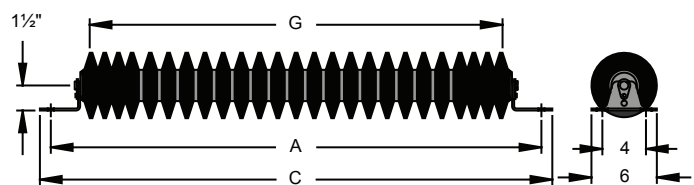

CHANNEL INSET FLAT IMPACT

Belt Width	4" Roll Diameter		5" Roll Diameter		Standard Dimensions		
	Part Number	WT	Part Number	WT	A	C	G
14	B4-CIFRD-14SB	17	B5-CIFRD-14SB	23	22	24	15
16	B4-CIFRD-16SB	19	B5-CIFRD-16SB	25	24	26	17
18	B4-CIFRD-18SB	21	B5-CIFRD-18SB	28	26	28	19
20	B4-CIFRD-20SB	23	B5-CIFRD-20SB	31	28	30	21
24	B4-CIFRD-24SB	26	B5-CIFRD-24SB	34	32	34	25
30	B4-CIFRD-30SB	32	B5-CIFRD-30SB	41	38	40	37
36	B4-CIFRD-36SB	37	B5-CIFRD-36SB	48	44	46	37
42	B4-CIFRD-42SB	43	B5-CIFRD-42SB	55	50	52	43
48	B4-CIFRD-48SB	48	B5-CIFRD-48SB	62	56	58	49

CEMA B CHANNEL INSET TROUGHING IDLER

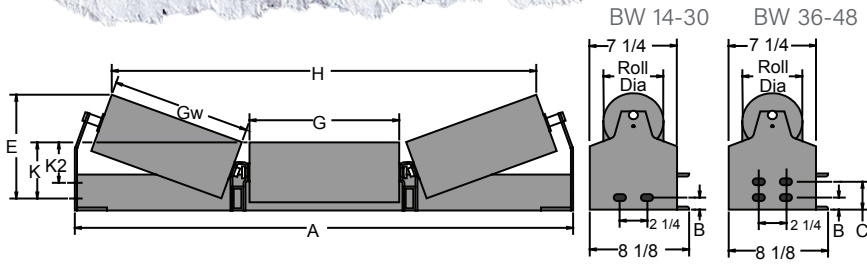

Belt Width	Standard Dimensions				
	A	B	C	G	Gw
14	19 5/8	15/8	-	5	4
16	21 5/8	15/8	-	5 3/4	4 3/4
18	23 5/8	15/8	-	6 1/2	5 1/2
20	25 5/8	15/8	-	7 1/8	6 1/8
24	29 5/8	15/8	-	8 1/2	7 1/2
30	35 5/8	15/8	-	10 1/2	9 1/2
36	41 5/8	1	2 5/16	12 1/2	11 1/2
42	47 5/8	1	2 5/16	18 1/2	11 1/2
48	53 5/8	1	2 5/16	24 1/2	11 1/2

20° CHANNEL INSET TROUGHING IDLER

Belt Width	4" Roll Diameter						5" Roll Diameter					
	Part Number	E	H	K	K2	WT	Part Number	E	H	K	K2	WT
14	B4-20CIT-14SB	4 3/4	13 13/16	3 3/8	-	22	B5-20CIT-14SB	5 1/4	13 7/16	3 7/8	-	24
16	B4-20CIT-16SB	5 1/16	15 15/16	3 3/8	-	23	B5-20CIT-16SB	5 1/2	15 5/8	3 7/8	-	26
18	B4-20CIT-18SB	5 1/4	18 1/16	3 3/8	-	25	B5-20CIT-18SB	5 3/4	17 3/4	3 7/8	-	28
20	B4-20CIT-20SB	5 1/2	19 7/8	3 3/8	-	27	B5-20CIT-20SB	5 15/16	19 9/16	3 7/8	-	30
24	B4-20CIT-24SB	5 15/16	23 7/8	3 3/8	-	31	B5-20CIT-24SB	6 7/16	23 1/2	3 7/8	-	34
30	B4-20CIT-30SB	6 11/16	29 5/8	3 3/8	-	36	B5-20CIT-30SB	7 1/8	29 1/4	3 7/8	-	40
36	B4-20CIT-36SB	8	35 3/8	4	2 11/16	41	B5-20CIT-36SB	8 7/16	35 1/16	4 1/2	3 3/16	46
42	B4-20CIT-42SB	8	41 3/8	4	2 11/16	46	B5-20CIT-42SB	8 7/16	41 1/16	4 1/2	3 3/16	52
48	B4-20CIT-48SB	8	47 3/8	4	2 11/16	51	B5-20CIT-48SB	8 7/16	47 1/16	4 1/2	3 3/16	57

35° CHANNEL INSET TROUGHING IDLER

Belt Width	4" Roll Diameter						5" Roll Diameter					
	Part Number	E	H	K	K2	WT	Part Number	E	H	K	K2	WT
14	B4-35CIT-14SB	5 11/16	12 11/16	3 3/8	-	22	B5-35CIT-14SB	6 1/8	12 1/8	3 7/8	-	25
16	B4-35CIT-16SB	6 1/8	14 11/16	3 3/8	-	24	B5-35CIT-16SB	6 1/2	14 1/8	3 7/8	-	27
18	B4-35CIT-18SB	6 9/16	16 5/8	3 3/8	-	26	B5-35CIT-18SB	6 15/16	16 1/16	3 7/8	-	29
20	B4-35CIT-20SB	6 15/16	18 5/16	3 3/8	-	28	B5-35CIT-20SB	7 3/8	17 3/4	3 7/8	-	31
24	B4-35CIT-24SB	7 3/4	21 15/16	3 3/8	-	32	B5-35CIT-24SB	8 1/8	21 5/16	3 7/8	-	35
30	B4-35CIT-30SB	8 7/8	27 3/16	3 3/8	-	37	B5-35CIT-30SB	9 1/4	26 5/8	3 7/8	-	41
36	B4-35CIT-36SB	10 5/8	32 1/2	4	2 11/16	43	B5-35CIT-36SB	11 1/16	31 15/16	4 1/2	7 1/2	47
42	B4-35CIT-42SB	10 5/8	38 1/2	4	2 11/16	47	B5-35CIT-42SB	11 1/16	37 15/16	4 1/2	8	52
48	B4-35CIT-48SB	10 5/8	44 1/2	4	2 11/16	52	B5-35CIT-48SB	11 1/16	43 15/16	4 1/2	8	58

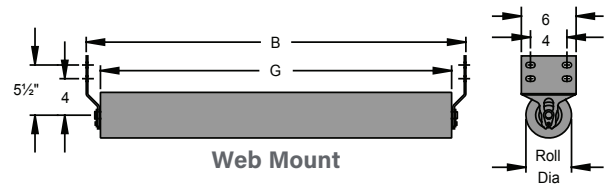
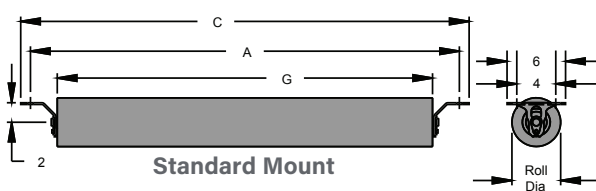

CHANNEL INSET RETURN

Belt Width	Standard Mount				Web Mount				Standard Dimensions			
	4" Roll Diameter		5" Roll Diameter		4" Roll Diameter		5" Roll Diameter					
	Part Number	WT	Part Number	WT	Part Number	WT	Part Number	WT	A	B	C	G
14	B4-CIR-14SB	15	B5-CIR-14SB	18	B4-CIRW-14SB	16	B5-CIRW-14SB	19	22	19 5/8	24	16 1/2
16	B4-CIR-16SB	16	B5-CIR-16SB	19	B4-CIRW-16SB	17	B5-CIRW-16SB	20	24	21 5/8	26	18 1/2
18	B4-CIR-18SB	17	B5-CIR-18SB	20	B4-CIRW-18SB	18	B5-CIRW-18SB	21	26	23 5/8	28	20 1/2
20	B4-CIR-20SB	18	B5-CIR-20SB	21	B4-CIRW-20SB	19	B5-CIRW-20SB	22	28	25 5/8	30	22 1/2
24	B4-CIR-24SB	20	B5-CIR-24SB	23	B4-CIRW-24SB	21	B5-CIRW-24SB	24	32	29 5/8	34	26 1/2
30	B4-CIR-30SB	23	B5-CIR-30SB	27	B4-CIRW-30SB	24	B5-CIRW-30SB	28	38	35 5/8	40	32 1/2
36	B4-CIR-36SB	26	B5-CIR-36SB	30	B4-CIRW-36SB	27	B5-CIRW-36SB	31	44	41 5/8	46	38 1/2
42	B4-CIR-42SB	29	B5-CIR-42SB	34	B4-CIRW-42SB	30	B5-CIRW-42SB	35	50	47 5/8	52	44 1/2
48	B4-CIR-48SB	31	B5-CIR-48SB	37	B4-CIRW-48SB	32	B5-CIRW-48SB	38	56	53 5/8	58	50 1/2

CEMA B CHANNEL INSET IMPACT TROUGHING IDLER

Belt Width	Standard Dimensions				
	A	B	C	G	Gw
14	19 5/8	15/8	-	27/8	27/8
16	21 5/8	15/8	-	35/8	35/8
18	23 5/8	15/8	-	43/8	43/8
20	25 5/8	15/8	-	5	5
24	29 5/8	15/8	-	6 3/8	6 3/8
30	35 5/8	15/8	-	8 3/8	8 3/8
36	41 5/8	1	2 5/16	10 3/8	10 3/8
42	47 5/8	1	2 5/16	16 3/8	10 3/8
48	53 5/8	1	2 5/16	22 3/8	10 3/8

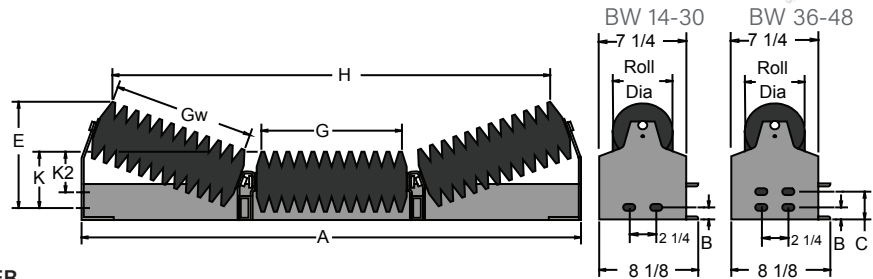

20° CHANNEL INSET IMPACT TROUGHING IDLER

Belt Width	4" Roll Diameter						5" Roll Diameter					
	Part Number	E	H	K	K2	WT	Part Number	E	H	K	K2	WT
14	B4-20CITI-14SB	4 3/4	13 13/16	3 3/8	-	26	B5-20CITI-14SB	5 1/4	13 7/16	3 7/8	-	29
16	B4-20CITI-16SB	5 1/16	15 15/16	3 3/8	-	27	B5-20CITI-16SB	5 1/2	15 5/8	3 7/8	-	30
18	B4-20CITI-18SB	5 1/4	18 1/16	3 3/8	-	31	B5-20CITI-18SB	5 3/4	17 3/4	3 7/8	-	35
20	B4-20CITI-20SB	5 1/2	19 7/8	3 3/8	-	35	B5-20CITI-20SB	5 15/16	19 9/16	3 7/8	-	40
24	B4-20CITI-24SB	5 15/16	23 7/8	3 3/8	-	40	B5-20CITI-24SB	6 7/16	23 1/2	3 7/8	-	46
30	B4-20CITI-30SB	6 11/16	29 5/8	3 3/8	-	48	B5-20CITI-30SB	7 1/8	29 1/4	3 7/8	-	54
36	B4-20CITI-36SB	8	35 3/8	4	2 11/16	57	B5-20CITI-36SB	8 7/16	35 1/16	4 1/2	3 3/16	65
42	B4-20CITI-42SB	8	41 3/8	4	2 11/16	63	B5-20CITI-42SB	8 7/16	41 1/16	4 1/2	3 3/16	73
48	B4-20CITI-48SB	8	47 3/8	4	2 11/16	72	B5-20CITI-48SB	8 7/16	47 1/16	4 1/2	3 3/16	83

35° CHANNEL INSET IMPACT TROUGHING IDLER

Belt Width	4" Roll Diameter						5" Roll Diameter					
	Part Number	E	H	K	K2	WT	Part Number	E	H	K	K2	WT
14	B4-35CITI-14SB	5 11/16	12 11/16	3 3/8	-	27	B5-35CITI-14SB	6 1/8	12 1/8	3 7/8	-	30
16	B4-35CITI-16SB	6 1/8	14 11/16	3 3/8	-	28	B5-35CITI-16SB	6 1/2	14 1/8	3 7/8	-	31
18	B4-35CITI-18SB	6 9/16	16 5/8	3 3/8	-	33	B5-35CITI-18SB	6 15/16	16 1/16	3 7/8	-	36
20	B4-35CITI-20SB	6 15/16	18 5/16	3 3/8	-	36	B5-35CITI-20SB	7 3/8	17 3/4	3 7/8	-	41
24	B4-35CITI-24SB	7 3/4	21 15/16	3 3/8	-	42	B5-35CITI-24SB	8 1/8	21 5/16	3 7/8	-	48
30	B4-35CITI-30SB	8 7/8	27 3/16	3 3/8	-	49	B5-35CITI-30SB	9 1/4	26 5/8	3 7/8	-	56
36	B4-35CITI-36SB	10 5/8	32 1/2	4	2 11/16	59	B5-35CITI-36SB	11 1/16	31 15/16	4 1/2	7 1/2	67
42	B4-35CITI-42SB	10 5/8	38 1/2	4	2 11/16	65	B5-35CITI-42SB	11 1/16	37 15/16	4 1/2	8	75
48	B4-35CITI-48SB	10 5/8	44 1/2	4	2 11/16	74	B5-35CITI-48SB	11 1/16	43 15/16	4 1/2	8	85

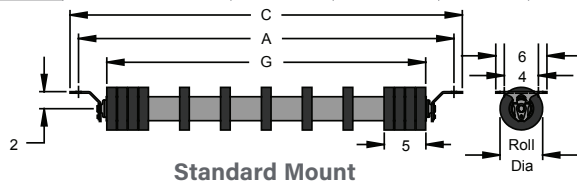

Standard Mount

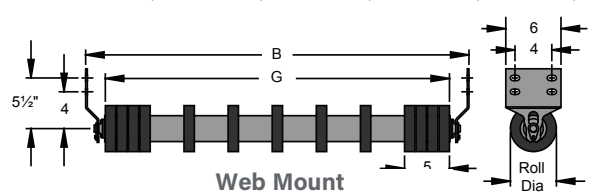

Web Mount

CHANNEL INSET RETURN RUBBER DISC

Belt Width	Standard Mount				Web Mount				Standard Dimensions			
	4" Roll Diameter		5" Roll Diameter		4" Roll Diameter		5" Roll Diameter					
	Part Number	WT	Part Number	WT	Part Number	WT	Part Number	WT	A	B	C	G
14	B4-CIRRD-14SB	17	B5-CIRRD-14SB	23	B4-CIRRDW-14SB	18	B5-CIRRDW-14SB	24	22	19 5/8	24	16
16	B4-CIRRD-16SB	18	B5-CIRRD-16SB	25	B4-CIRRDW-16SB	19	B5-CIRRDW-16SB	26	24	21 5/8	26	18
18	B4-CIRRD-18SB	19	B5-CIRRD-18SB	26	B4-CIRRDW-18SB	20	B5-CIRRDW-18SB	27	26	23 5/8	28	20
20	B4-CIRRD-20SB	20	B5-CIRRD-20SB	27	B4-CIRRDW-20SB	21	B5-CIRRDW-20SB	28	28	25 5/8	30	22
24	B4-CIRRD-24SB	22	B5-CIRRD-24SB	30	B4-CIRRDW-24SB	23	B5-CIRRDW-24SB	31	32	29 5/8	34	26
30	B4-CIRRD-30SB	27	B5-CIRRD-30SB	34	B4-CIRRDW-30SB	28	B5-CIRRDW-30SB	35	38	35 5/8	40	32
36	B4-CIRRD-36SB	30	B5-CIRRD-36SB	37	B4-CIRRDW-36SB	31	B5-CIRRDW-36SB	38	44	41 5/8	46	38
42	B4-CIRRD-42SB	34	B5-CIRRD-42SB	41	B4-CIRRDW-42SB	35	B5-CIRRDW-42SB	42	50	47 5/8	52	44
48	B4-CIRRD-48SB	37	B5-CIRRD-48SB	45	B4-CIRRDW-48SB	38	B5-CIRRDW-48SB	46	56	53 5/8	58	50

CEMA B SELF-ALIGNER – TROUGHING IDLER

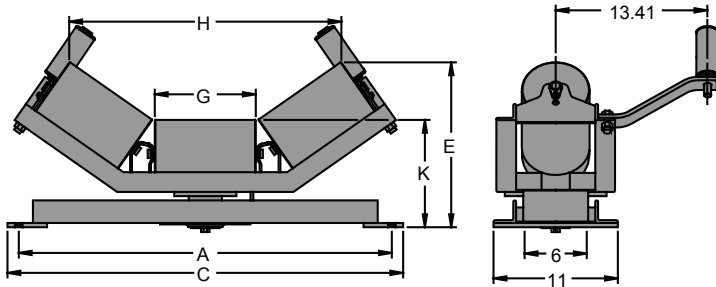

Belt Width	Standard Dimensions		
	A	C	G*
14	23	25	5 7/16
16	25	27	6 3/4
18	27	29	6 3/4
20	29	31	7 5/8
24	33	35	8 15/16
30	39	41	11 1/8
36	45	47	13 1/4
42	51	53	15 7/16
48	57	59	17 5/8

20° SELF-ALIGNER EQUAL TROUGHING IDLER

Belt Width	4" Roll Diameter					5" Roll Diameter				
	Part Number	E	H	K	WT	Part Number	E	H	K	WT
14	B4-20TESA-14SB	9 9/16	16 15/16	7 1/2	74	B5-20TESA-14SB	10	16 9/16	8	77
16	B4-20TESA-16SB	9 9/16	18 1/4	7 1/2	76	B5-20TESA-16SB	10	17 7/8	8	80
18	B4-20TESA-18SB	9 15/16	20 11/16	7 1/2	79	B5-20TESA-18SB	10 7/16	20 3/8	8	83
20	B4-20TESA-20SB	10 5/16	23 1/4	7 1/2	82	B5-20TESA-20SB	10 3/4	22 7/8	8	86
24	B4-20TESA-24SB	10 3/4	26 15/16	7 1/2	87	B5-20TESA-24SB	11 3/16	26 11/16	8	92
30	B4-20TESA-30SB	11 7/16	33 5/16	7 1/2	95	B5-20TESA-30SB	11 15/16	32 15/16	8	100
36	B4-20TESA-36SB	12 3/16	39 7/16	7 1/2	103	B5-20TESA-36SB	12 11/16	39 1/16	8	109
42	B4-20TESA-42SB	13 7/16	45 3/4	8	120	B5-20TESA-42SB	13 15/16	45 3/8	8 1/2	126
48	B4-20TESA-48SB	14 3/16	52 1/16	8	128	B5-20TESA-48SB	14 11/16	51 11/16	8 1/2	136

35° SELF-ALIGNER EQUAL TROUGHING IDLER

Belt Width	4" Roll Diameter					5" Roll Diameter				
	Part Number	E	H	K	WT	Part Number	E	H	K	WT
14	B4-35TESA-14SB	10 3/4	15 1/2	7 1/2	74	B5-35TESA-14SB	11 3/16	14 7/8	8	77
16	B4-35TESA-16SB	10 3/4	16 13/16	7 1/2	76	B5-35TESA-16SB	11 3/16	16 1/4	8	79
18	B4-35TESA-18SB	11 7/16	18 15/16	7 1/2	79	B5-35TESA-18SB	11 7/8	18 3/8	8	82
20	B4-35TESA-20SB	12	21 1/4	7 1/2	81	B5-35TESA-20SB	12 7/16	20 11/16	8	85
24	B4-35TESA-24SB	12 3/4	24 11/16	7 1/2	87	B5-35TESA-24SB	13 1/8	24 1/8	8	91
30	B4-35TESA-30SB	14	30 1/2	7 1/2	91	B5-35TESA-30SB	14 7/16	29 7/8	8	100
36	B4-35TESA-36SB	15 3/16	36 1/8	7 1/2	102	B5-35TESA-36SB	15 5/8	35 1/2	8	108
42	B4-35TESA-42SB	16 15/16	41 7/8	8	119	B5-35TESA-42SB	17 3/8	41 1/4	8 1/2	126
48	B4-35TESA-48SB	18 3/16	47 5/8	8	128	B5-35TESA-48SB	18 5/8	47 1/16	8 1/2	135

45° SELF-ALIGNER EQUAL TROUGHING IDLER

Belt Width	4" Roll Diameter					5" Roll Diameter				
	Part Number	E	H	K	WT	Part Number	E	H	K	WT
14	B4-45TESA-14SB	11 11/16	14 1/8	7 1/2	76	B5-45TESA-14SB	12	13 7/16	8	80
16	B4-45TESA-16SB	11 11/16	15 7/16	7 1/2	78	B5-45TESA-16SB	12	14 11/16	8	82
18	B4-45TESA-18SB	12 5/8	17 1/4	7 1/2	81	B5-45TESA-18SB	12 15/16	16 9/16	8	85
20	B4-45TESA-20SB	13 3/16	19 3/8	7 1/2	84	B5-45TESA-20SB	13 9/16	18 11/16	8	88
24	B4-45TESA-24SB	14 1/8	22 9/16	7 1/2	89	B5-45TESA-24SB	14 7/16	21 7/8	8	94
30	B4-45TESA-30SB	15 11/16	27 11/16	7 1/2	97	B5-45TESA-30SB	16 1/16	27 1/8	8	103
36	B4-45TESA-36SB	17 3/16	32 15/16	7 1/2	105	B5-45TESA-36SB	17 9/16	32 1/4	8	111
42	B4-45TESA-42SB	19 3/16	38 1/4	8	121	B5-45TESA-42SB	19 9/16	37 9/16	8 1/2	128
48	B4-45TESA-48SB	20 3/4	43 9/16	8	130	B5-45TESA-48SB	21 1/8	42 13/16	8 1/2	138

*16" belt width G=6 3/4" for center roll and 5 7/16" for wing roll.

CEMA B SELF-ALIGNER RETURN & FLAT

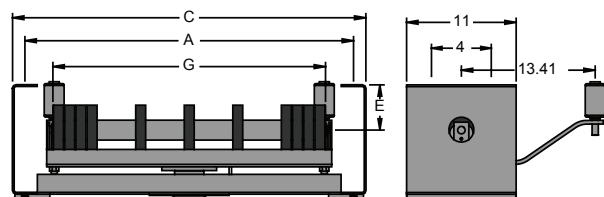
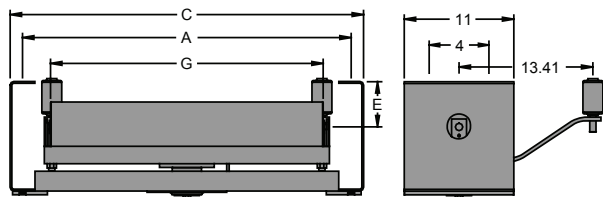

RETURN SELF-ALIGNER

Belt Width	4" Roll Diameter				5" Roll Diameter				Standard Dimensions		
	E=4½"	WT	E=1½"	WT	E=4½"	WT	E=1½"	WT	A	C	G
14	B4-RSA-14SB	81	B4-RSA-14SB-1	77	B5-RSA-14SB	83	B5-RSA-14SB-1	80	23	25	17 3/8
16	B4-RSA-16SB	83	B4-RSA-16SB-1	80	B5-RSA-16SB	86	B5-RSA-16SB-1	82	25	27	19 3/8
18	B4-RSA-18SB	86	B4-RSA-18SB-1	85	B5-RSA-18SB	89	B5-RSA-18SB-1	85	27	29	21 3/8
20	B4-RSA-20SB	88	B4-RSA-20SB-1	85	B5-RSA-20SB	91	B5-RSA-20SB-1	88	29	31	23 3/8
24	B4-RSA-24SB	93	B4-RSA-24SB-1	90	B5-RSA-24SB	97	B5-RSA-24SB-1	94	33	35	27 3/8
30	B4-RSA-30SB	101	B4-RSA-30SB-1	98	B5-RSA-30SB	105	B5-RSA-30SB-1	102	39	41	33 3/8
36	B4-RSA-36SB	109	B4-RSA-36SB-1	105	B5-RSA-36SB	114	B5-RSA-36SB-1	110	45	47	39 3/8
42	B4-RSA-42SB	122	B4-RSA-42SB-1	119	B5-RSA-42SB	128	B5-RSA-42SB-1	125	51	53	45 3/8
48	B4-RSA-48SB	130	B4-RSA-48SB-1	127	B5-RSA-48SB	137	B5-RSA-48SB-1	134	57	59	51 3/8

RETURN RUBBER DISC SELF-ALIGNER

Belt Width	4" Roll Diameter				5" Roll Diameter				Standard Dimensions		
	E=4½"	WT	E=1½"	WT	E=4½"	WT	E=1½"	WT	A	C	G
14	B4-RRDSA-14SB	86	B4-RRDSA-14SB-1	82	B5-RRDSA-14SB	88	B5-RRDSA-14SB-1	85	23	25	16 7/8
16	B4-RRDSA-16SB	89	B4-RRDSA-16SB-1	85	B5-RRDSA-16SB	92	B5-RRDSA-16SB-1	89	25	27	18 7/8
18	B4-RRDSA-18SB	91	B4-RRDSA-18SB-1	88	B5-RRDSA-18SB	95	B5-RRDSA-18SB-1	91	27	29	20 7/8
20	B4-RRDSA-20SB	94	B4-RRDSA-20SB-1	91	B5-RRDSA-20SB	97	B5-RRDSA-20SB-1	94	29	31	22 7/8
24	B4-RRDSA-24SB	100	B4-RRDSA-24SB-1	97	B5-RRDSA-24SB	103	B5-RRDSA-24SB-1	100	33	35	26 7/8
30	B4-RRDSA-30SB	108	B4-RRDSA-30SB-1	105	B5-RRDSA-30SB	112	B5-RRDSA-30SB-1	109	39	41	32 7/8
36	B4-RRDSA-36SB	117	B4-RRDSA-36SB-1	114	B5-RRDSA-36SB	121	B5-RRDSA-36SB-1	118	45	47	38 7/8
42	B4-RRDSA-42SB	131	B4-RRDSA-42SB-1	128	B5-RRDSA-42SB	136	B5-RRDSA-42SB-1	132	51	53	44 7/8
48	B4-RRDSA-48SB	140	B4-RRDSA-48SB-1	137	B5-RRDSA-48SB	145	B5-RRDSA-48SB-1	142	57	59	50 7/8

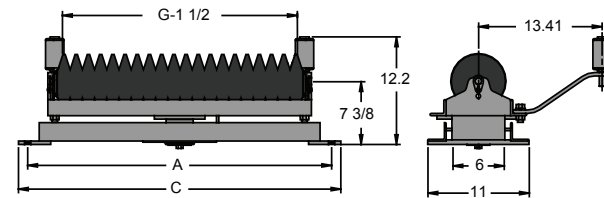
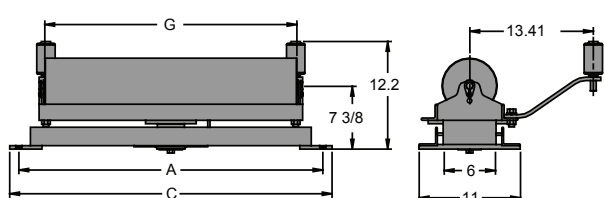

FLAT CARRIER SELF-ALIGNER

Belt Width	Steel Rolls				Rubber Disc Rolls				Standard Dimensions		
	4" Roll Diameter		5" Roll Diameter		4" Roll Diameter		5" Roll Diameter				
	Part Number	WT	Part Number	WT	Part Number	WT	Part Number	WT	A	C	G
14	B4-FSA-14SB	64	B5-FSA-14SB	67	B4-FRDSA-14SB	69	B5-FRDSA-14SB	72	23	25	15 7/8
16	B4-FSA-16SB	67	B5-FSA-16SB	70	B4-FRDSA-16SB	72	B5-FRDSA-16SB	76	25	27	17 7/8
18	B4-FSA-18SB	69	B5-FSA-18SB	72	B4-FRDSA-18SB	75	B5-FRDSA-18SB	79	27	29	19 7/8
20	B4-FSA-20SB	72	B5-FSA-20SB	75	B4-FRDSA-20SB	78	B5-FRDSA-20SB	82	29	31	21 7/8
24	B4-FSA-24SB	77	B5-FSA-24SB	81	B4-FRDSA-24SB	83	B5-FRDSA-24SB	88	33	35	25 7/8
30	B4-FSA-30SB	85	B5-FSA-30SB	89	B4-FRDSA-30SB	93	B5-FRDSA-30SB	99	39	41	31 7/8
36	B4-FSA-36SB	92	B5-FSA-36SB	98	B4-FRDSA-36SB	102	B5-FRDSA-36SB	110	45	47	37 7/8
42	B4-FSA-42SB	106	B5-FSA-42SB	112	B4-FRDSA-42SB	118	B5-FRDSA-42SB	126	51	53	43 7/8
48	B4-FSA-48SB	114	B5-FSA-48SB	121	B4-FRDSA-48SB	128	B5-FRDSA-48SB	138	57	59	49 7/8

CEMA C CLASS IDLERS PRODUCT OFFERINGS

- Equal Troughing Idler
- Equal Impact Troughing Idler
- Unequal Troughing Idler
- Unequal Impact Troughing Idler
- Flat Carrier
- Impact Flat Carrier
- Return Roller
- Return Rubber Disc
- Channel Inset Flat Carrier
- Channel Inset Flat Rubber Disc Carrier
- Channel Inset Troughing Idler
- Channel Inset Return Roller
- Channel Inset Impact Troughing Idler
- Channel Inset Impact Return Roller
- Self-Aligner Troughing Idler
- Self-Aligner Return Roller
- Self-Aligner Flat Roller
- Additional Configurations Available

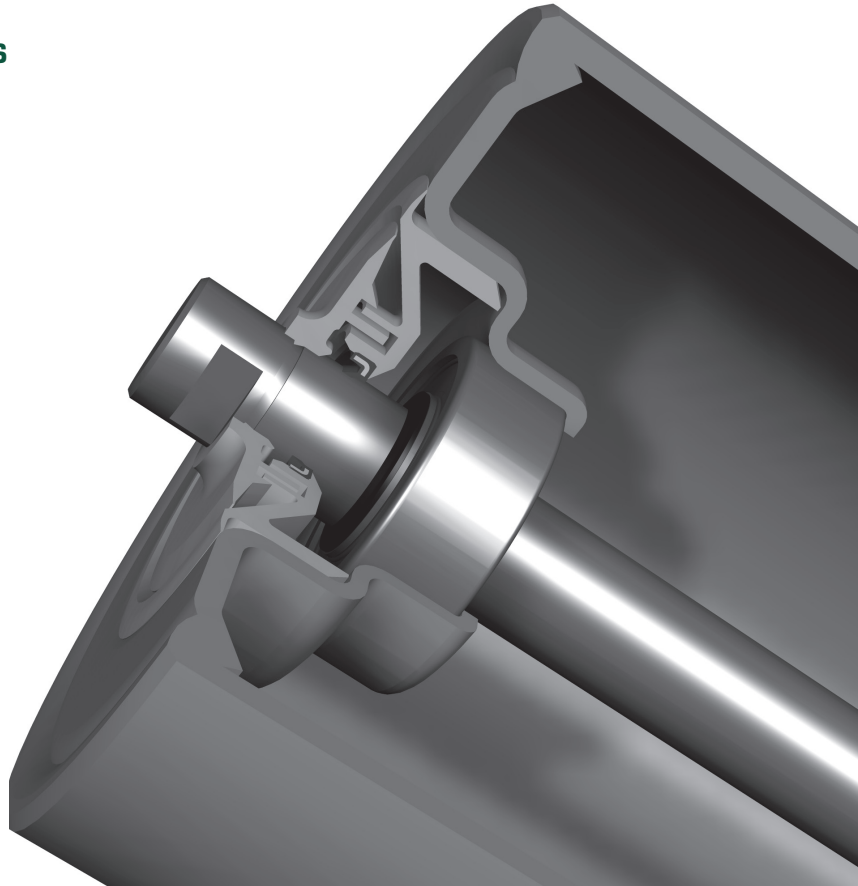

CEMA C LOAD RATINGS

BELT WIDTH	TROUGHING ANGLE			RETURN & FLAT	TWO-ROLL V-RETURNS	UNEQUAL (Picking)	LIVE SHAFT
	20°	35°	45°				
18	900	900	900	475	500	475	1200
24	900	900	900	325	500	475	1200
30	900	900	900	250	500	475	1200
36	900	837	810	200	500	325	1200
42	850	791	765	150	500	250	1,100
48	800	744	720	125	500	200	1,000
54	750	698	675	CEMA D	500	150	875
60	700	650	630	CEMA D	500	125	780
66	-	-	-	CEMA D	500	-	-

CEMA C EQUAL TROUGHING IDLER

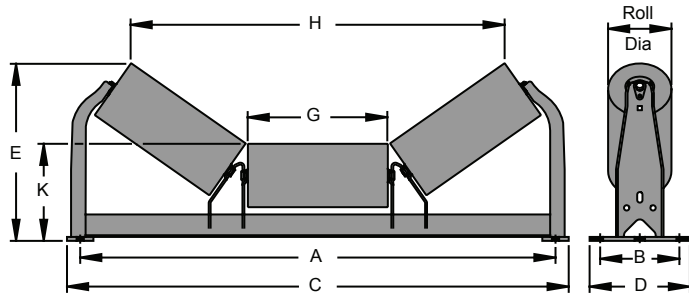

Belt Width	Standard Dimensions					Wide Base	
	A	B	C	D	G	Aw	Cw
18	27	6	29	8	6 3/4	33	35
20	29	6	31	8	7 5/8	35	37
24	33	6	35	8	8 15/16	39	41
30	39	6	41 1/2	9 1/2	11 1/8	45	47 1/2
36	45	6	47 1/2	9 1/2	13 1/4	51	53 1/2
42	51	7 1/2	53 1/2	9 1/2	15 7/16	57	59 1/2
48	57	7 1/2	59 1/2	9 1/2	17 5/8	63	65 1/2
54	63	9	65 1/2	10 15/16	19 3/4	69	71 1/2
60	69	9	71 1/2	11	21 3/4	75	77 1/2

20° EQUAL TROUGHING IDLER

Belt Width	4" Roll Diameter					5" Roll Diameter					6" Roll Diameter				
	Part Number	E	H	K	WT	Part Number	E	H	K	WT	Part Number	E	H	K	WT
18	C4-20TE-18SB	10 7/16	21 1/16	8	34	C5-20TE-18SB	10 15/16	20 11/16	8 1/2	39	C6-20TE-18SB	11 3/8	20 3/8	9	45
20	C4-20TE-20SB	10 3/4	23 9/16	8	37	C5-20TE-20SB	11 1/4	23 1/4	8 1/2	42	C6-20TE-20SB	11 11/16	22 7/8	9	49
24	C4-20TE-24SB	11 3/16	27 3/8	8	41	C5-20TE-24SB	11 11/16	27 1/16	8 1/2	46	C6-20TE-24SB	12 1/8	26 11/16	9	54
30	C4-20TE-30SB	12 1/8	33 5/8	8 1/8	49	C5-20TE-30SB	12 9/16	33 3/8	8 5/8	55	C6-20TE-30SB	13 1/16	32 15/16	9 1/8	64
36	C4-20TE-36SB	12 13/16	39 3/4	8 1/8	56	C5-20TE-36SB	13 5/16	39 7/16	8 5/8	64	C6-20TE-36SB	13 3/4	39 1/8	9 1/8	74
42	C4-20TE-42SB	13 15/16	46 1/16	8 1/2	73	C5-20TE-42SB	14 7/16	45 3/4	9	81	C6-20TE-42SB	14 7/8	45 7/16	9 1/2	92
48	C4-20TE-48SB	14 11/16	52 3/8	8 1/2	80	C5-20TE-48SB	15 3/16	52 1/16	9	89	C6-20TE-48SB	15 5/8	51 3/4	9 1/2	102
54	C4-20TE-54SB	15 7/16	58 1/2	8 1/2	89	C5-20TE-54SB	15 7/8	58 3/16	9	99	C6-20TE-54SB	16 3/8	57 13/16	9 1/2	112
60	C4-20TE-60SB	16 1/16	64 1/4	8 1/2	96	C5-20TE-60SB	16 9/16	63 7/8	9	106	C6-20TE-60SB	17	63 9/16	9 1/2	121

35° EQUAL TROUGHING IDLER

Belt Width	4" Roll Diameter					5" Roll Diameter					6" Roll Diameter				
	Part Number	E	H	K	WT	Part Number	E	H	K	WT	Part Number	E	H	K	WT
18	C4-35TE-18SB	12 1/8	19 3/8	8	35	C5-35TE-18SB	12 9/16	18 13/16	8 1/2	40	C6-35TE-18SB	13 1/16	18 1/4	9	46
20	C4-35TE-20SB	12 5/8	21 11/16	8	38	C5-35TE-20SB	13 1/16	21 1/8	8 1/2	43	C6-35TE-20SB	13 1/2	20 9/16	9	50
24	C4-35TE-24SB	13 3/8	25 1/8	8	42	C5-35TE-24SB	13 13/16	24 9/16	8 1/2	48	C6-35TE-24SB	14 1/4	24 1/16	9	55
30	C4-35TE-30SB	14 3/4	30 15/16	8 1/8	50	C5-35TE-30SB	15 3/16	30 3/8	8 5/8	57	C6-35TE-30SB	15 11/16	29 13/16	9 1/8	66
36	C4-35TE-36SB	15 15/16	36 1/2	8 1/8	58	C5-35TE-36SB	16 3/8	35 15/16	8 5/8	66	C6-35TE-36SB	16 13/16	35 7/16	9 1/8	75
42	C4-35TE-42SB	17 5/8	42 5/16	8 1/2	75	C5-35TE-42SB	18 1/16	41 3/4	9	84	C6-35TE-42SB	18 7/16	41 3/16	9 1/2	95
48	C4-35TE-48SB	18 7/8	48 1/16	8 1/2	83	C5-35TE-48SB	19 5/16	47 1/2	9	92	C6-35TE-48SB	19 11/16	46 15/16	9 1/2	104
54	C4-35TE-54SB	20 1/8	53 11/16	8 1/2	96	C5-35TE-54SB	20 1/2	53 1/8	9	106	C6-35TE-54SB	20 15/16	52 9/16	9 1/2	120
60	C4-35TE-60SB	21 1/4	58 15/16	8 1/2	103	C5-35TE-60SB	21 11/16	58 3/8	9	113	C6-35TE-60SB	22 1/16	57 7/8	9 1/2	128

45° EQUAL TROUGHING IDLER

Belt Width	4" Roll Diameter					5" Roll Diameter					6" Roll Diameter				
	Part Number	E	H	K	WT	Part Number	E	H	K	WT	Part Number	E	H	K	WT
18	C4-45TE-18SB	13 3/16	18 1/8	8	37	C5-45TE-18SB	13 1/2	17 1/2	8 1/2	42	C6-45TE-18SB	13 7/8	16 13/16	9	48
20	C4-45TE-20SB	13 3/4	20 5/16	8	39	C5-45TE-20SB	14 1/8	19 5/8	8 1/2	44	C6-45TE-20SB	14 1/2	18 15/16	9	51
24	C4-45TE-24SB	14 11/16	23 3/8	8	43	C5-45TE-24SB	15 1/16	22 3/4	8 1/2	49	C6-45TE-24SB	15 3/8	22 1/8	9	57
30	C4-45TE-30SB	16 3/8	28 11/16	8 1/8	52	C5-45TE-30SB	16 3/4	28 1/16	8 5/8	58	C6-45TE-30SB	17 1/16	27 3/8	9 1/8	67
36	C4-45TE-36SB	17 7/8	33 7/8	8 1/8	59	C5-45TE-36SB	18 3/16	33 1/8	8 5/8	67	C6-45TE-36SB	18 9/16	32 5/16	9 1/8	77
42	C4-45TE-42SB	19 13/16	39 1/8	8 1/2	75	C5-45TE-42SB	20 1/8	38 7/16	9	84	C6-45TE-42SB	20 1/2	37 11/16	9 1/2	95
48	C4-45TE-48SB	21 3/8	44 7/16	8 1/2	86	C5-45TE-48SB	21 11/16	43 11/16	9	95	C6-45TE-48SB	22 1/16	43 1/16	9 1/2	108
54	C4-45TE-54SB	22 7/8	49 9/16	8 1/2	97	C5-45TE-54SB	23 3/16	48 13/16	9	107	C6-45TE-54SB	23 9/16	48 1/16	9 1/2	121
60	C4-45TE-60SB	24 1/4	54 3/8	8 1/2	104	C5-45TE-60SB	24 5/8	53 11/16	9	114	C6-45TE-60SB	24 15/16	53	9 1/2	129

CEMA C EQUAL IMPACT TROUGHING IDLER

Belt Width	Standard Dimensions					Wide Base	
	A	B	C	D	G	Aw	Cw
18	27	6	29	8	5 1/4	33	35
20	29	6	31	8	6 1/8	35	37
24	33	6	35	8	7 7/16	39	41
30	39	6	41 1/2	9 1/2	9 5/8	45	47 1/2
36	45	6	47 1/2	9 1/2	11 3/4	51	53 1/2
42	51	7 1/2	53 1/2	9 1/2	13 15/16	57	59 1/2
48	57	7 1/2	59 1/2	9 1/2	16 1/8	63	65 1/2
54	63	9	65 1/2	10 15/16	18 1/4	69	71 1/2
60	69	9	71 1/2	11	20 1/4	75	77 1/2

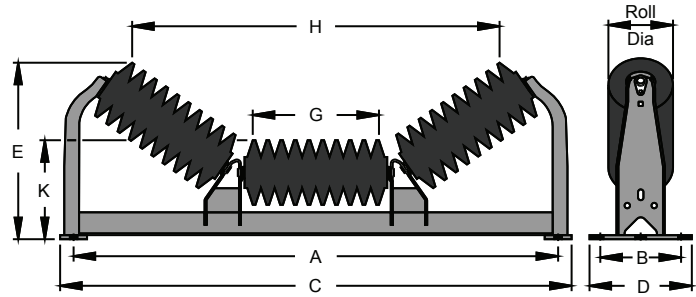

20° EQUAL IMPACT TROUGHING IDLER

Belt Width	4" Roll Diameter					5" Roll Diameter					6" Roll Diameter				
	Part Number	E	H	K	WT	Part Number	E	H	K	WT	Part Number	E	H	K	WT
18	C4-20TEI-18SB	10 3/16	19 5/8	8	41	C5-20TEI-18SB	10 11/16	19 1/4	8 1/2	45	C6-20TEI-18SB	11 1/8	18 15/16	9	51
20	C4-20TEI-20SB	10 1/2	22 1/8	8	43	C5-20TEI-20SB	11	21 13/16	8 1/2	48	C6-20TEI-20SB	11 7/16	21 7/16	9	54
24	C4-20TEI-24SB	10 15/16	25 15/16	8	48	C5-20TEI-24SB	11 7/16	25 5/8	8 1/2	54	C6-20TEI-24SB	11 7/8	25 1/4	9	61
30	C4-20TEI-30SB	11 7/8	32 3/16	8 1/8	59	C5-20TEI-30SB	12 5/16	31 15/16	8 5/8	66	C6-20TEI-30SB	12 3/4	31 1/2	9 1/8	75
36	C4-20TEI-36SB	12 9/16	38 5/16	8 1/8	69	C5-20TEI-36SB	13 1/16	38	8 5/8	78	C6-20TEI-36SB	13 1/2	37 11/16	9 1/8	90
42	C4-20TEI-42SB	13 11/16	44 5/8	8 1/2	88	C5-20TEI-42SB	14 3/16	44 5/16	9	99	C6-20TEI-42SB	14 5/8	44	9 1/2	113
48	C4-20TEI-48SB	14 7/16	50 15/16	8 1/2	97	C5-20TEI-48SB	14 15/16	50 5/8	9	109	C6-20TEI-48SB	15 3/8	50 1/4	9 1/2	122
54	C4-20TEI-54SB	15 3/16	57 1/16	8 1/2	111	C5-20TEI-54SB	15 5/8	56 3/4	9	122	C6-20TEI-54SB	16 1/8	56 3/8	9 1/2	139
60	C4-20TEI-60SB	15 13/16	62 13/16	8 1/2	119	C5-20TEI-60SB	16 5/16	62 7/16	9	133	C6-20TEI-60SB	16 3/4	62 1/8	9 1/2	153

35° EQUAL IMPACT TROUGHING IDLER

Belt Width	4" Roll Diameter					5" Roll Diameter					6" Roll Diameter				
	Part Number	E	H	K	WT	Part Number	E	H	K	WT	Part Number	E	H	K	WT
18	C4-35TEI-18SB	11 11/16	18 1/8	8	42	C5-35TEI-18SB	12 1/8	17 9/16	8 1/2	47	C6-35TEI-18SB	12 5/8	17	9	53
20	C4-35TEI-20SB	12 3/16	20 7/16	8	45	C5-35TEI-20SB	12 5/8	19 7/8	8 1/2	50	C6-35TEI-20SB	13 1/16	19 5/16	9	56
24	C4-35TEI-24SB	12 15/16	23 7/8	8	50	C5-35TEI-24SB	13 3/8	23 5/16	8 1/2	56	C6-35TEI-24SB	13 13/16	22 13/16	9	63
30	C4-35TEI-30SB	14 5/16	29 11/16	8 1/8	62	C5-35TEI-30SB	14 3/4	29 1/8	8 5/8	68	C6-35TEI-30SB	15 1/4	28 9/16	9 1/8	78
36	C4-35TEI-36SB	15 1/2	35 1/4	8 1/8	71	C5-35TEI-36SB	15 15/16	34 11/16	8 5/8	80	C6-35TEI-36SB	16 3/8	34 3/16	9 1/8	92
42	C4-35TEI-42SB	17 3/16	41 1/16	8 1/2	91	C5-35TEI-42SB	17 5/8	40 1/2	9	102	C6-35TEI-42SB	18	39 15/16	9 1/2	116
48	C4-35TEI-48SB	18 7/16	46 13/16	8 1/2	100	C5-35TEI-48SB	18 7/8	46 1/4	9	112	C6-35TEI-48SB	19 1/4	45 11/16	9 1/2	125
54	C4-35TEI-54SB	19 11/16	52 7/16	8 1/2	118	C5-35TEI-54SB	20 1/16	51 7/8	9	129	C6-35TEI-54SB	20 1/2	51 5/16	9 1/2	147
60	C4-35TEI-60SB	20 13/16	57 11/16	8 1/2	126	C5-35TEI-60SB	21 1/4	57 1/8	9	140	C6-35TEI-60SB	21 5/8	56 5/8	9 1/2	160

45° EQUAL IMPACT TROUGHING IDLER

Belt Width	4" Roll Diameter					5" Roll Diameter					6" Roll Diameter				
	Part Number	E	H	K	WT	Part Number	E	H	K	WT	Part Number	E	H	K	WT
18	C4-45TEI-18SB	12 11/16	17 1/16	8	43	C5-45TEI-18SB	13	16 7/16	8 1/2	48	C6-45TEI-18SB	13 3/8	15 3/4	9	54
20	C4-45TEI-20SB	13 1/4	19 1/4	8	46	C5-45TEI-20SB	13 5/8	18 9/16	8 1/2	51	C6-45TEI-20SB	14	17 7/8	9	57
24	C4-45TEI-24SB	14 3/16	22 5/16	8	51	C5-45TEI-24SB	14 9/16	21 11/16	8 1/2	57	C6-45TEI-24SB	14 7/8	21 1/16	9	64
30	C4-45TEI-30SB	15 7/8	27 5/8	8 1/8	63	C5-45TEI-30SB	16 1/4	27	8 5/8	70	C6-45TEI-30SB	16 5/8	26 5/16	9 1/8	79
36	C4-45TEI-36SB	17 3/8	32 13/16	8 1/8	72	C5-45TEI-36SB	17 11/16	32 1/16	8 5/8	81	C6-45TEI-36SB	18 1/16	31 1/4	9 1/8	93
42	C4-45TEI-42SB	19 5/16	38 1/16	8 1/2	91	C5-45TEI-42SB	19 5/8	37 3/8	9	102	C6-45TEI-42SB	20	36 5/8	9 1/2	115
48	C4-45TEI-48SB	20 7/8	43 3/8	8 1/2	103	C5-45TEI-48SB	21 3/16	42 5/8	9	115	C6-45TEI-48SB	21 9/16	42	9 1/2	128
54	C4-45TEI-54SB	22 3/8	48 1/2	8 1/2	119	C5-45TEI-54SB	22 11/16	47 3/4	9	130	C6-45TEI-54SB	23 1/16	47	9 1/2	148
60	C4-45TEI-60SB	23 3/4	53 5/16	8 1/2	127	C5-45TEI-60SB	24 1/8	52 5/8	9	141	C6-45TEI-60SB	24 7/16	51 15/16	9 1/2	160

CEMA C UNEQUAL TROUGHING & FLAT CARRIER IDLERS

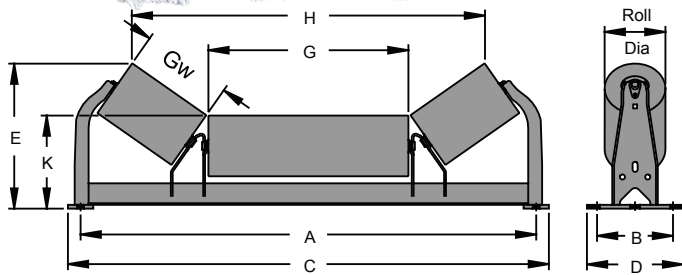

Belt Width	Standard Dimensions				Wide Base	
	A	B	C	D	Aw	Cw
24	33	6	35 1/2	8	39	41 1/2
30	39	6	41 1/2	9 1/2	45	47 1/2
36	45	6	47 1/2	9 1/2	51	53 1/2
42	51	7 1/2	53 1/2	9 1/2	57	59 1/2
48	57	7 1/2	59 1/2	9 1/2	63	65 1/2
54	63	9	65 1/2	10 15/16	69	71 1/2
60	69	9	71 1/2	11	75	77 1/2

20° UNEQUAL TROUGHING IDLER

Belt Width	4" Roll Diameter					5" Roll Diameter					6" Roll Diameter					G	Gw
	Part Number	E	H	K	WT	Part Number	E	H	K	WT	Part Number	E	H	K	WT		
24	C4-20TU-24SB	10 1/8	27 5/16	8 1/8	40	C5-20TU-24SB	10 5/8	27	8 5/8	46	C6-20TU-24SB	11 1/16	26 11/16	9 1/8	53	15 7/16	5 7/16
30	C4-20TU-30SB	10 1/8	33 1/4	8 1/8	47	C5-20TU-30SB	10 5/8	32 15/16	8 5/8	54	C6-20TU-30SB	11 1/16	32 9/16	9 1/8	62	21 3/8	5 7/16
36	C4-20TU-36SB	10 1/8	39 1/4	8 1/8	54	C5-20TU-36SB	10 5/8	38 7/8	8 5/8	62	C6-20TU-36SB	11 1/16	38 9/16	9 1/8	71	27 3/8	5 7/16
42	C4-20TU-42SB	10 9/16	45 1/4	8 1/2	69	C5-20TU-42SB	11	44 7/8	9	77	C6-20TU-42SB	11 7/16	44 9/16	9 1/2	87	33 3/8	5 7/16
48	C4-20TU-48SB	10 9/16	51 1/4	8 1/2	75	C5-20TU-48SB	11	50 7/8	9	84	C6-20TU-48SB	11 7/16	50 9/16	9 1/2	96	39 3/8	5 7/16
54	C4-20TU-54SB	10 9/16	57 1/4	8 1/2	83	C5-20TU-54SB	11	56 7/8	9	92	C6-20TU-54SB	11 7/16	56 9/16	9 1/2	105	45 3/8	5 7/16
60	C4-20TU-60SB	10 9/16	63 1/4	8 1/2	90	C5-20TU-60SB	11	62 7/8	9	100	C6-20TU-60SB	11 7/16	62 9/16	9 1/2	114	51 3/8	5 7/16

35° UNEQUAL TROUGHING IDLER

Belt Width	4" Roll Diameter					5" Roll Diameter					6" Roll Diameter					G	Gw
	Part Number	E	H	K	WT	Part Number	E	H	K	WT	Part Number	E	H	K	WT		
24	C4-35TU-24SB	12 3/8	25 7/8	8 1/8	42	C5-35TU-24SB	12 3/4	25 1/4	8 5/8	47	C6-35TU-24SB	13 3/16	24 3/4	9 1/8	55	13 1/4	6 3/4
30	C4-35TU-30SB	13 5/8	31 5/8	8 1/8	50	C5-35TU-30SB	14	31 1/16	8 5/8	56	C6-35TU-30SB	14 3/8	30 1/2	9 1/8	65	15 7/16	8 15/16
36	C4-35TU-36SB	13 1/2	35 15/16	8 1/8	56	C5-35TU-36SB	13 15/16	35 3/8	8 5/8	63	C6-35TU-36SB	14 5/16	34 7/8	9 1/8	72	19 3/4	8 15/16
42	C4-35TU-42SB	15 3/16	41 3/16	8 1/2	70	C5-35TU-42SB	15 9/16	40 5/8	9	78	C6-35TU-42SB	15 15/16	40 1/16	9 1/2	89	21 3/8	11 1/8
48	C4-35TU-48SB	15 3/16	47 3/16	8 1/2	77	C5-35TU-48SB	15 9/16	46 5/8	9	86	C6-35TU-48SB	15 15/16	46 1/16	9 1/2	97	27 3/8	11 1/8
54	C4-35TU-54SB	15 3/16	53 3/16	8 1/2	85	C5-35TU-54SB	15 9/16	52 5/8	9	94	C6-35TU-54SB	15 15/16	52 1/16	9 1/2	107	33 3/8	11 1/8
60	C4-35TU-60SB	15 3/16	59 3/16	8 1/2	91	C5-35TU-60SB	15 9/16	58 5/8	9	101	C6-35TU-60SB	15 15/16	58 1/16	9 1/2	115	39 3/8	11 1/8

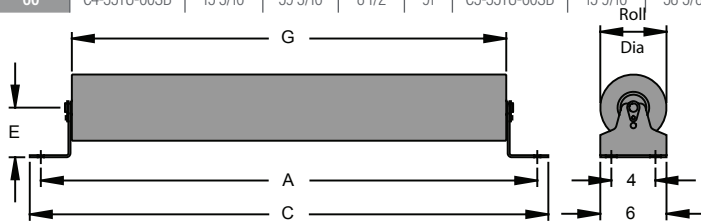

FLAT CARRIER

Belt Width	4" Roll Diameter				5" Roll Diameter				6" Roll Diameter				Standard Dimensions		
	E=4 1/2"		E=1 1/2"		E=4 1/2"		E=1 1/2"		E=4 1/2"		E=1 1/2"		A	C	G
	Part Number	WT	Part Number	WT	Part Number	WT	Part Number	WT	Part Number	WT	Part Number	WT			
18	C4-F-18SB	22	C4-F-18SB-1	21	C5-F-18SB	26	C5-F-18SB-1	25	C6-F-18SB	31	C6-F-18SB-1	30	27	29	21 3/8
20	C4-F-20SB	24	C4-F-20SB-1	23	C5-F-20SB	27	C5-F-20SB-1	26	C6-F-20SB	32	C6-F-20SB-1	31	29	31	23 3/8
24	C4-F-24SB	26	C4-F-24SB-1	25	C5-F-24SB	31	C5-F-24SB-1	30	C6-F-24SB	36	C6-F-24SB-1	35	33	35	27 3/8
30	C4-F-30SB	30	C4-F-30SB-1	29	C5-F-30SB	35	C5-F-30SB-1	34	C6-F-30SB	42	C6-F-30SB-1	41	39	41	33 3/8
36	C4-F-36SB	34	C4-F-36SB-1	33	C5-F-36SB	39	C5-F-36SB-1	38	C6-F-36SB	48	C6-F-36SB-1	47	45	47	39 3/8
42	C4-F-42SB	37	C4-F-42SB-1	36	C5-F-42SB	44	C5-F-42SB-1	43	C6-F-42SB	53	C6-F-42SB-1	52	51	53	45 3/8
48	C4-F-48SB	41	C4-F-48SB-1	40	C5-F-48SB	49	C5-F-48SB-1	48	C6-F-48SB	59	C6-F-48SB-1	58	57	59	51 3/8
54*	C4-F-54SB	45	C4-F-54SB-1	44	C5-F-54SB	53	C5-F-54SB-1	52	C6-F-54SB	65	C6-F-54SB-1	64	63	65	57 3/8
60*	C4-F-60SB	49	C4-F-60SB-1	48	C5-F-60SB	58	C5-F-60SB-1	57	C6-F-60SB	70	C6-F-60SB-1	69	69	71	63 3/8

*CEMA recommends D Idlers for 54" and 60" Flat Idlers.

CEMA C UNEQUAL IMPACT TROUGHING & FLAT CARRIER

Belt Width	Standard Dimensions				Wide Base	
	A	B	C	D	Aw	Cw
24	33	6	35 1/2	8	39	41 1/2
30	39	6	41 1/2	9 1/2	45	47 1/2
36	45	6	47 1/2	9 1/2	51	53 1/2
42	51	7 1/2	53 1/2	9 1/2	57	59 1/2
48	57	7 1/2	59 1/2	9 1/2	63	65 1/2
54	63	9	65 1/2	10 15/16	69	71 1/2
60	69	9	71 1/2	11	75	77 1/2

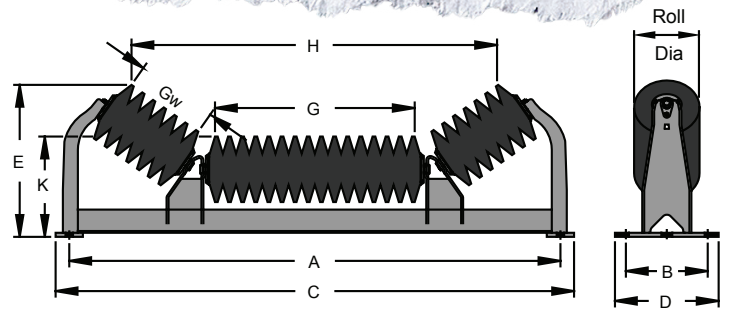

20° UNEQUAL IMPACT TROUGHING IDLER

Belt Width	5" Roll Diameter					6" Roll Diameter					G	Gw
	Part Number	E	H	K	WT	Part Number	E	H	K	WT		
24	C5-20TUI-24SB	10 3/8	25 9/16	8 5/8	56	C6-20TUI-24SB	10 13/16	25 1/4	9 1/8	64	13 15/16	3 15/16
30	C5-20TUI-30SB	10 3/8	31 1/2	8 5/8	70	C6-20TUI-30SB	10 13/16	31 1/8	9 1/8	78	19 7/8	3 15/16
36	C5-20TUI-36SB	10 3/8	37 7/16	8 5/8	80	C6-20TUI-36SB	10 13/16	37 1/8	9 1/8	91	25 7/8	3 15/16
42	C5-20TUI-42SB	10 3/4	43 7/16	9	99	C6-20TUI-42SB	11 3/16	43 1/8	9 1/2	111	31 7/8	3 15/16
48	C5-20TUI-48SB	10 3/4	49 7/16	9	109	C6-20TUI-48SB	11 3/16	49 1/8	9 1/2	122	37 7/8	3 15/16
54	C5-20TUI-54SB	10 3/4	55 7/16	9	122	C6-20TUI-54SB	11 3/16	55 1/8	9 1/2	137	43 7/8	3 15/16
60	C5-20TUI-60SB	10 3/4	61 7/16	9	134	C6-20TUI-60SB	11 3/16	61 1/8	9 1/2	150	49 7/8	3 15/16

35° UNEQUAL IMPACT TROUGHING IDLER

Belt Width	5" Roll Diameter					6" Roll Diameter					G	Gw
	Part Number	E	H	K	WT	Part Number	E	H	K	WT		
24	C5-35TUI-24SB	12 5/16	24	8 5/8	56	C6-35TUI-24SB	12 3/4	23 1/2	9 1/8	64	11 3/4	5 1/4
30	C5-35TUI-30SB	13 9/16	29 13/16	8 5/8	67	C6-35TUI-30SB	13 15/16	29 1/4	9 1/8	77	13 15/16	7 7/16
36	C5-35TUI-36SB	13 1/2	34 1/8	8 5/8	77	C6-35TUI-36SB	13 7/8	33 5/8	9 1/8	87	18 25/32	7 7/16
42	C5-35TUI-42SB	15 1/8	39 3/8	9	99	C6-35TUI-42SB	15 1/2	38 13/16	9 1/2	110	19 7/8	9 5/8
48	C5-35TUI-48SB	15 1/8	45 3/8	9	110	C6-35TUI-48SB	15 1/2	44 13/16	9 1/2	123	25 7/8	9 5/8
54	C5-35TUI-54SB	15 1/8	51 3/8	9	122	C6-35TUI-54SB	15 1/2	50 13/16	9 1/2	136	31 7/8	9 5/8
60	C5-35TUI-60SB	15 1/8	57 3/8	9	133	C6-35TUI-60SB	15 1/2	56 13/16	9 1/2	149	38 7/8	9 5/8

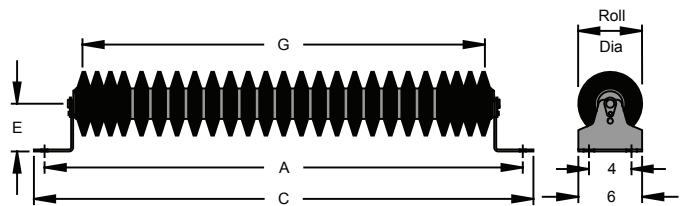

FLAT RUBBER DISC CARRIER

Belt Width	5" Roll Diameter				6" Roll Diameter				Standard Dimensions		
	E=4 1/2"		E=1 1/2"		E=4 1/2"		E=1 1/2"		A	C	G
	Part Number	WT	Part Number	WT	Part Number	WT	Part Number	WT			
18	C5-FRD-18SB	31	C5-FRD-18SB-1	30	C6-FRD-18SB	37	C6-FRD-18SB-1	36	27	29	19 7/8
20	C5-FRD-20SB	33	C5-FRD-20SB-1	32	C6-FRD-20SB	38	C6-FRD-20SB-1	37	29	31	21 7/8
24	C5-FRD-24SB	38	C5-FRD-24SB-1	37	C6-FRD-24SB	45	C6-FRD-24SB-1	44	33	35	25 7/8
30	C5-FRD-30SB	45	C5-FRD-30SB-1	44	C6-FRD-30SB	53	C6-FRD-30SB-1	52	39	41	31 7/8
36	C5-FRD-36SB	51	C5-FRD-36SB-1	50	C6-FRD-36SB	61	C6-FRD-36SB-1	60	45	47	37 7/8
42	C5-FRD-42SB	58	C5-FRD-42SB-1	57	C6-FRD-42SB	69	C6-FRD-42SB-1	68	51	53	43 7/8
48	C5-FRD-48SB	65	C5-FRD-48SB-1	64	C6-FRD-48SB	78	C6-FRD-48SB-1	77	57	59	49 7/8
54*	C5-FRD-54SB	72	C5-FRD-54SB-1	71	C6-FRD-54SB	86	C6-FRD-54SB-1	85	63	65	55 7/8
60*	C5-FRD-60SB	78	C5-FRD-60SB-1	77	C6-FRD-60SB	88	C6-FRD-60SB-1	87	69	71	61 7/8

*CEMA recommends D Idlers for 54" and 60" Flat Idlers.

CEMA C RETURN & V-RETURN

Belt Width	Standard Dimensions		
	A	C	G
18	27	29	21 3/8
20	29	31	23 3/8
24	33	35	27 3/8
30	39	41	33 3/8
36	45	47	39 3/8
42	51	53	45 3/8
48	57	59	51 3/8
54	63	65	57 3/8
60	69	71	63 3/8

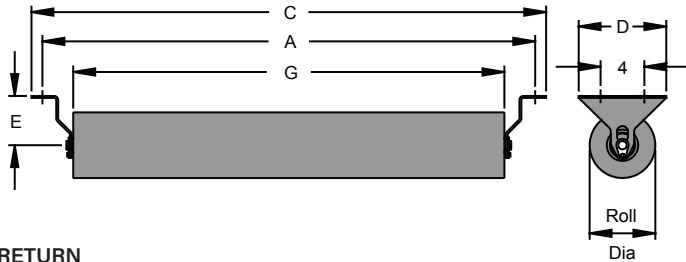

RETURN

Belt Width	4" Roll Diameter					5" Roll Diameter					6" Roll Diameter				
	Std E=4 1/2"		Opt E=1 1/2"		WT	Std E=4 1/2"		Opt E=1 1/2"		WT	Std E=4 1/2"		Opt E=1 1/2"		WT
	Part Number	D	Part Number	D		Part Number	D	Part Number	D		Part Number	D	Part Number	D	
18	C4-R-18SB	8	C4-R-18SB-1	6	20	C5-R-18SB	8	C5-R-18SB-1	6	23	C6-R-18SB	8	C6-R-18SB-1	6	28
20	C4-R-20SB	8	C4-R-20SB-1	6	21	C5-R-20SB	8	C5-R-20SB-1	6	25	C6-R-20SB	8	C6-R-20SB-1	6	30
24	C4-R-24SB	8	C4-R-24SB-1	6	23	C5-R-24SB	8	C5-R-24SB-1	6	28	C6-R-24SB	8	C6-R-24SB-1	6	34
30	C4-R-30SB	8	C4-R-30SB-1	6	27	C5-R-30SB	8	C5-R-30SB-1	6	32	C6-R-30SB	8	C6-R-30SB-1	6	39
36	C4-R-36SB	8	C4-R-36SB-1	6	31	C5-R-36SB	8	C5-R-36SB-1	6	37	C6-R-36SB	8	C6-R-36SB-1	6	45
42	C4-R-42SB	8	C4-R-42SB-1	6	35	C5-R-42SB	8	C5-R-42SB-1	6	41	C6-R-42SB	8	C6-R-42SB-1	6	51
48	C4-R-48SB	8	C4-R-48SB-1	6	38	C5-R-48SB	8	C5-R-48SB-1	6	46	C6-R-48SB	8	C6-R-48SB-1	6	56
54*	C4-R-54SB	8	C4-R-54SB-1	6	42	C5-R-54SB	8	C5-R-54SB-1	6	50	C6-R-54SB	8	C6-R-54SB-1	6	62
60*	C4-R-60SB	8	C4-R-60SB-1	6	46	C5-R-60SB	8	C5-R-60SB-1	6	55	C6-R-60SB	8	C6-R-60SB-1	6	68

*CEMA recommends D Idlers for 54" and 60" Flat Idlers.

Belt Width	Standard Dimensions		
	A	C	G
24	33	35	13 5/8
30	39	41	16 11/16
36	45	47	19 3/4
42	51	53	22 13/16
48	57	59	25 7/8
54	63	65	28 7/8
60	69	71	31 15/16

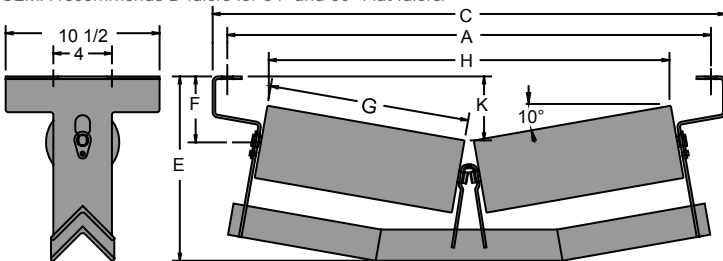

V-RETURN IDLER (F = 4 1/2")

Belt Width	5" Roll Diameter					6" Roll Diameter				
	Part Number	E	H	K	WT	Part Number	E	H	K	WT
24	C5-10VR-24SB-4	13 1/8	27 1/2	4 1/2	48	C6-10VR-24SB-4	13 1/8	27 3/8	4	56
30	C5-10VR-30SB-4	13 5/8	33 1/2	5	55	C6-10VR-30SB-4	13 5/8	33 3/8	4 1/2	64
36	C5-10VR-36SB-4	14 3/16	39 1/2	5 9/16	61	C6-10VR-36SB-4	14 3/16	39 3/8	5 1/16	72
42	C5-10VR-42SB-4	14 11/16	45 9/16	6 1/8	68	C6-10VR-42SB-4	14 11/16	45 3/8	5 5/8	80
48	C5-10VR-48SB-4	15 1/4	51 1/2	6 5/8	75	C6-10VR-48SB-4	15 1/4	51 3/8	6 1/8	87
54	C5-10VR-54SB-4	15 3/4	57 1/2	7 3/16	81	C6-10VR-54SB-4	15 3/4	57 3/8	6 11/16	95
60	C5-10VR-60SB-4	16 1/4	63 1/2	7 11/16	88	C6-10VR-60SB-4	16 1/4	63 3/8	7 1/4	103

V-RETURN IDLER (F = 7")

Belt Width	5" Roll Diameter					6" Roll Diameter				
	Part Number	E	H	K	WT	Part Number	E	H	K	WT
24	C5-10VR-24SB-7	15 5/8	27 1/2	7	51	C6-10VR-24SB-7	15 5/8	27 3/8	6 1/2	59
30	C5-10VR-30SB-7	16 1/8	33 1/2	7 1/2	58	C6-10VR-30SB-7	16 1/8	33 3/8	7	67
36	C5-10VR-36SB-7	16 11/16	39 1/2	8 1/16	64	C6-10VR-36SB-7	16 11/16	39 3/8	7 5/8	74
42	C5-10VR-42SB-7	17 3/16	45 9/16	8 5/8	71	C6-10VR-42SB-7	17 3/16	45 3/8	8 1/8	82
48	C5-10VR-48SB-7	17 3/4	51 1/2	9 1/8	77	C6-10VR-48SB-7	17 3/4	51 3/8	8 5/8	90
54	C5-10VR-54SB-7	18 1/4	57 1/2	9 5/8	84	C6-10VR-54SB-7	18 1/4	57 3/8	9 3/16	98
60	C5-10VR-60SB-7	18 3/4	63 1/2	10 1/4	90	C6-10VR-60SB-7	18 3/4	63 3/8	9 3/4	106

CEMA C RETURN RUBBER DISC & V-RETURN RUBBER DISC

Belt Width	Standard Dimensions		
	A	C	G
18	27	29	20 7/8
20	29	31	22 7/8
24	33	35	26 7/8
30	39	41	32 7/8
36	45	47	38 7/8
42	51	53	44 7/8
48	57	59	50 7/8
54	63	65	56 7/8
60	69	71	62 7/8

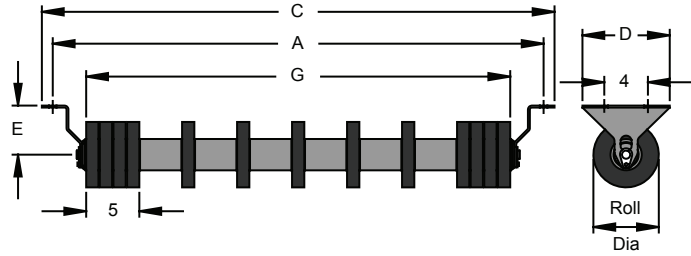

RETURN RUBBER DISC

Belt Width	4" Roll Diameter					5" Roll Diameter					6" Roll Diameter				
	Std E=4 1/2"		Opt E=1 1/2"		WT	Std E=4 1/2"		Opt E=1 1/2"		WT	Std E=4 1/2"		Opt E=1 1/2"		WT
	Part Number	D	Part Number	D		Part Number	D	Part Number	D		Part Number	D	Part Number	D	
18	C4-RRD-18SB	8	C4-RRD-18SB-1	6	18	C5-RRD-18SB	8	C5-RRD-18SB-1	6	22	C6-RRD-18SB	8	C6-RRD-18SB-1	6	27
20	C4-RRD-20SB	8	C4-RRD-20SB-1	6	19	C5-RRD-20SB	8	C5-RRD-20SB-1	6	23	C6-RRD-20SB	8	C6-RRD-20SB-1	6	27
24	C4-RRD-24SB	8	C4-RRD-24SB-1	6	21	C5-RRD-24SB	8	C5-RRD-24SB-1	6	26	C6-RRD-24SB	8	C6-RRD-24SB-1	6	30
30	C4-RRD-30SB	8	C4-RRD-30SB-1	6	24	C5-RRD-30SB	8	C5-RRD-30SB-1	6	29	C6-RRD-30SB	8	C6-RRD-30SB-1	6	34
36	C4-RRD-36SB	8	C4-RRD-36SB-1	6	27	C5-RRD-36SB	8	C5-RRD-36SB-1	6	32	C6-RRD-36SB	8	C6-RRD-36SB-1	6	38
42	C4-RRD-42SB	8	C4-RRD-42SB-1	6	30	C5-RRD-42SB	8	C5-RRD-42SB-1	6	36	C6-RRD-42SB	8	C6-RRD-42SB-1	6	42
48	C4-RRD-48SB	8	C4-RRD-48SB-1	6	32	C5-RRD-48SB	8	C5-RRD-48SB-1	6	39	C6-RRD-48SB	8	C6-RRD-48SB-1	6	45
54*	C4-RRD-54SB	8	C4-RRD-54SB-1	6	35	C5-RRD-54SB	8	C5-RRD-54SB-1	6	42	C6-RRD-54SB	8	C6-RRD-54SB-1	6	49
60*	C4-RRD-60SB	8	C4-RRD-60SB-1	6	38	C5-RRD-60SB	8	C5-RRD-60SB-1	6	46	C6-RRD-60SB	8	C6-RRD-60SB-1	6	53

*CEMA recommends D Idlers for 54" and 60" Flat Idlers.

Belt Width	Standard Dimensions		
	A	C	G
24	33	35	13 1/8
30	39	41	16 3/16
36	45	47	19 1/4
42	51	53	22 5/16
48	57	59	25 3/8
54	63	65	28 3/8
60	69	71	31 7/16

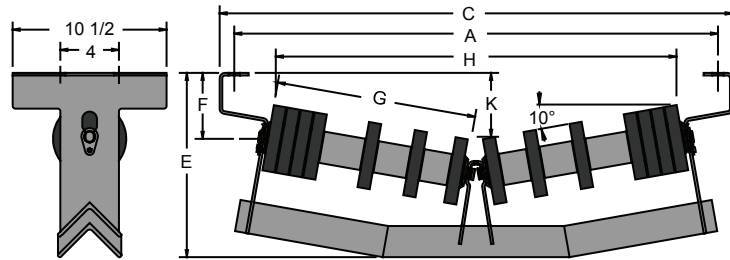

V-RETURN RUBBER DISC IDLER (F = 4 1/2")

Belt Width	5" Roll Diameter					6" Roll Diameter				
	Part Number	E	H	K	WT	Part Number	E	H	K	WT
24	C5-10VRI-24SB-4	13 1/8	26 7/8	4 1/2	48	C6-10VRI-24SB-4	13 1/8	27 1/16	4	55
30	C5-10VRI-30SB-4	13 5/8	32 7/8	5	52	C6-10VRI-30SB-4	13 5/8	33 1/16	4.5	59
36	C5-10VRI-36SB-4	14 3/16	38 7/8	5 9/16	56	C6-10VRI-36SB-4	14 3/16	39 1/16	5 1/16	63
42	C5-10VRI-42SB-4	14 11/16	44 15/16	6 1/8	63	C6-10VRI-42SB-4	14 11/16	45 1/16	5.625	70
48	C5-10VRI-48SB-4	15 1/4	50 7/8	6 5/8	67	C6-10VRI-48SB-4	15 1/4	51 1/16	6 1/8	75
54	C5-10VRI-54SB-4	15 3/4	56 7/8	7 3/16	73	C6-10VRI-54SB-4	15 3/4	57 1/16	6 11/16	82
60	C5-10VRI-60SB-4	16 1/4	62 7/8	7 11/16	79	C6-10VRI-60SB-4	16 1/4	63 1/16	7 1/4	89

V-RETURN IDLER RUBBER DISC (F = 7")

Belt Width	5" Roll Diameter					6" Roll Diameter				
	Part Number	E	H	K	WT	Part Number	E	H	K	WT
24	C5-10VRI-24SB-7	15 5/8	26 7/8	7	51	C6-10VRI-24SB-7	15 5/8	27 1/16	6 1/2	58
30	C5-10VRI-30SB-7	16 1/8	32 7/8	7 1/2	55	C6-10VRI-30SB-7	16 1/8	33 1/16	7	62
36	C5-10VRI-36SB-7	16 11/16	38 7/8	8 1/16	59	C6-10VRI-36SB-7	16 11/16	39 1/16	7 5/8	66
42	C5-10VRI-42SB-7	17 3/16	44 15/16	8 5/8	65	C6-10VRI-42SB-7	17 3/16	45 1/16	8 1/8	73
48	C5-10VRI-48SB-7	17 3/4	50 7/8	9 1/8	70	C6-10VRI-48SB-7	17 3/4	51 1/16	8 5/8	77
54	C5-10VRI-54SB-7	18 1/4	56 7/8	9 5/8	76	C6-10VRI-54SB-7	18 1/4	57 1/16	9 3/16	84
60	C5-10VRI-60SB-7	18 3/4	62 7/8	10 1/4	82	C6-10VRI-60SB-7	18 3/4	63 1/16	9 3/4	91

CEMA C CHANNEL INSET TROUGHING & RETURN IDLERS

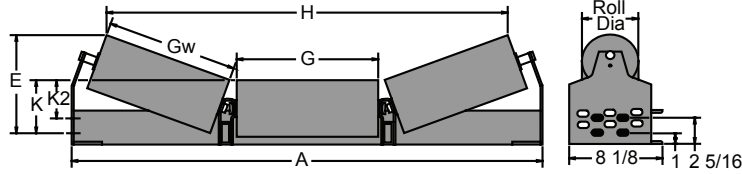

Belt Width	Standard Dimensions		
	A	G	Gw
18	23 5/8	6 1/2	5 1/2
20	25 5/8	7 1/8	6 1/8
24	29 5/8	8 1/2	7 1/2
30	35 5/8	10 1/2	9 1/2
36	41 5/8	12 1/2	11 1/2
42	47 5/8	18 1/2	11 1/2
48	53 5/8	24 1/2	11 1/2
54	59 5/8	30 1/2	11 1/2
60	65 5/8	36 1/2	11 1/2

20° CHANNEL INSET TROUGHING IDLER

Belt Width	4" Roll Diameter						5" Roll Diameter					
	Part Number	E	H	K	K2	WT	Part Number	E	H	K	K2	WT
18	C4-20CIT-18SB	6 3/16	18 1/2	4 3/16	2 7/8	34	C5-20CIT-18SB	6 5/8	18	4 11/16	3 3/8	39
20	C4-20CIT-20SB	6 3/8	20 1/4	4 3/16	2 7/8	36	C5-20CIT-20SB	6 7/8	19 15/16	4 11/16	3 3/8	41
24	C4-20CIT-24SB	6 7/8	24 1/4	4 3/16	2 7/8	41	C5-20CIT-24SB	7 5/16	23 7/8	4 11/16	3 3/8	46
30	C4-20CIT-30SB	7 9/16	30	4 3/16	2 7/8	47	C5-20CIT-30SB	8	29 5/8	4 11/16	3 3/8	52
36	C4-20CIT-36SB	8 3/16	35 3/4	4 3/16	2 7/8	53	C5-20CIT-36SB	8 11/16	35 7/16	4 11/16	3 3/8	60
42	C4-20CIT-42SB	8 3/16	41 3/4	4 3/16	2 7/8	59	C5-20CIT-42SB	8 11/16	41 7/16	4 11/16	3 3/8	67
48	C4-20CIT-48SB	8 3/16	47 3/4	4 3/16	2 7/8	65	C5-20CIT-48SB	8 11/16	47 7/16	4 11/16	3 3/8	74
54	C4-20CIT-54SB	8 3/16	53 3/4	4 3/16	2 7/8	71	C5-20CIT-54SB	8 11/16	53 7/16	4 11/16	3 3/8	80
60	C4-20CIT-60SB	8 3/16	59 3/4	4 3/16	2 7/8	75	C5-20CIT-60SB	8 11/16	59 7/16	4 11/16	3 3/8	85

35° CHANNEL INSET TROUGHING IDLER

Belt Width	4" Roll Diameter						5" Roll Diameter					
	Part Number	E	H	K	K2	WT	Part Number	E	H	K	K2	WT
18	C4-35CIT-18SB	7 9/16	17 1/8	4 3/16	2 7/8	36	C5-35CIT-18SB	7 15/16	16 9/16	4 11/16	3 3/8	40
20	C4-35CIT-20SB	7 7/8	18 3/4	4 3/16	2 7/8	38	C5-35CIT-20SB	8 5/16	18 3/16	4 11/16	3 3/8	43
24	C4-35CIT-24SB	8 11/16	22 3/8	4 3/16	2 7/8	42	C5-35CIT-24SB	9 1/16	21 13/16	4 11/16	3 3/8	48
30	C4-35CIT-30SB	9 13/16	27 5/8	4 3/16	2 7/8	49	C5-35CIT-30SB	10 1/4	27 1/16	4 11/16	3 3/8	54
36	C4-35CIT-36SB	11	32 15/16	4 3/16	2 7/8	56	C5-35CIT-36SB	11 3/8	32 5/16	4 11/16	3 3/8	62
42	C4-35CIT-42SB	11	38 15/16	4 3/16	2 7/8	63	C5-35CIT-42SB	11 3/8	38 5/16	4 11/16	3 3/8	70
48	C4-35CIT-48SB	11	44 15/16	4 3/16	2 7/8	68	C5-35CIT-48SB	11 3/8	44 5/16	4 11/16	3 3/8	76
54	C4-35CIT-54SB	11	50 15/16	4 3/16	2 7/8	74	C5-35CIT-54SB	11 3/8	50 5/16	4 11/16	3 3/8	84
60	C4-35CIT-60SB	11	56 15/16	4 3/16	2 7/8	80	C5-35CIT-60SB	11 3/8	56 5/16	4 11/16	3 3/8	90

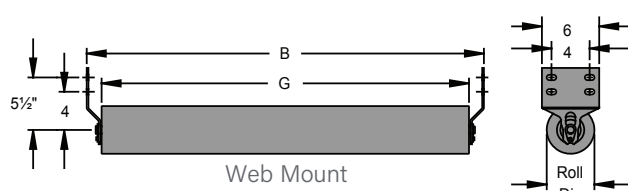
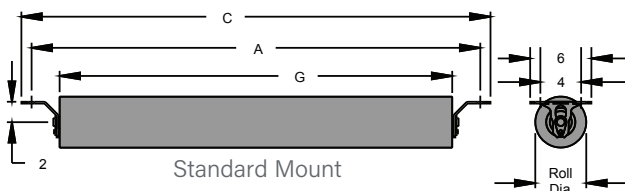

CHANNEL INSET RETURN

Belt Width	Standard Mount				Web Mount				Standard Dimensions			
	4" Roll Diameter		5" Roll Diameter		4" Roll Diameter		5" Roll Diameter		A	B	C	G
	Part Number	WT	Part Number	WT	Part Number	WT	Part Number	WT				
18	C4-CIR-18SB	20	C5-CIR-18SB	23	C4-CIRW-18SB	21	C5-CIRW-18SB	24	26	23 5/8	28	20 1/2
20	C4-CIR-20SB	21	C5-CIR-20SB	25	C4-CIRW-20SB	22	C5-CIRW-20SB	26	28	25 5/8	30	22 1/2
24	C4-CIR-24SB	24	C5-CIR-24SB	28	C4-CIRW-24SB	25	C5-CIRW-24SB	29	32	29 5/8	34	26 1/2
30	C4-CIR-30SB	28	C5-CIR-30SB	32	C4-CIRW-30SB	29	C5-CIRW-30SB	33	38	35 5/8	40	32 1/2
36	C4-CIR-36SB	31	C5-CIR-36SB	37	C4-CIRW-36SB	32	C5-CIRW-36SB	38	44	41 5/8	46	38 1/2
42	C4-CIR-42SB	35	C5-CIR-42SB	41	C4-CIRW-42SB	36	C5-CIRW-42SB	42	50	47 5/8	52	44 1/2
48	C4-CIR-48SB	39	C5-CIR-48SB	46	C4-CIRW-48SB	40	C5-CIRW-48SB	47	56	53 5/8	58	50 1/2
54*	C4-CIR-54SB	43	C5-CIR-54SB	50	C4-CIRW-54SB	44	C5-CIRW-54SB	51	62	59 5/8	64	56 1/2
60*	C4-CIR-60SB	46	C5-CIR-60SB	55	C4-CIRW-60SB	47	C5-CIRW-60SB	56	68	65 5/8	70	62 1/2

*CEMA recommends D Idlers for 54" and 60" Flat Idlers.

CEMA C CHANNEL INSET IMPACT TROUGHING & RETURN IDLER

Belt Width	Standard Dimensions		
	A	G	Gw
18	23 5/8	5	4
20	25 5/8	5 5/8	4 5/8
24	29 5/8	7	6
30	35 5/8	9	8
36	41 5/8	11	10
42	47 5/8	17	10
48	53 5/8	23	10
54	59 5/8	29	10
60	65 5/8	35	10

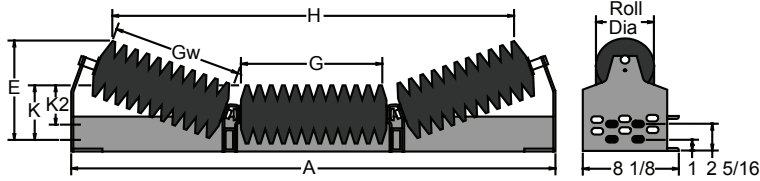

20° CHANNEL INSET IMPACT TROUGHING IDLER

Belt Width	4" Roll Diameter						5" Roll Diameter					
	Part Number	E	H	K	K2	WT	Part Number	E	H	K	K2	WT
18	C4-20CITI-18SB	5 15/16	17 1/16	4 3/16	2 7/8	33	C5-20CITI-18SB	6 3/8	16 9/16	4 11/16	3 3/8	37
20	C4-20CITI-20SB	6 1/8	18 13/16	4 3/16	2 7/8	37	C5-20CITI-20SB	6 5/8	18 1/2	4 11/16	3 3/8	40
24	C4-20CITI-24SB	6 5/8	22 13/16	4 3/16	2 7/8	42	C5-20CITI-24SB	7 1/16	22 7/16	4 11/16	3 3/8	46
30	C4-20CITI-30SB	7 5/16	28 56/25	4 3/16	2 7/8	50	C5-20CITI-30SB	7 3/4	28 3/16	4 11/16	3 3/8	55
36	C4-20CITI-36SB	7 15/16	34 5/16	4 3/16	2 7/8	56	C5-20CITI-36SB	8 7/16	34	4 11/16	3 3/8	65
42	C4-20CITI-42SB	7 15/16	40 5/16	4 3/16	2 7/8	64	C5-20CITI-42SB	8 7/16	40	4 11/16	3 3/8	74
48	-	-	-	-	-	-	C5-20CITI-48SB	8 7/16	46	4 11/16	3 3/8	84
54	-	-	-	-	-	-	C5-20CITI-54SB	8 7/16	52	4 11/16	3 3/8	94
60	-	-	-	-	-	-	C5-20CITI-60SB	8 7/16	58	4 11/16	3 3/8	102

35° CHANNEL INSET IMPACT TROUGHING IDLER

Belt Width	4" Roll Diameter						5" Roll Diameter					
	Part Number	E	H	K	K2	WT	Part Number	E	H	K	K2	WT
18	C4-35CITI-18SB	7 1/8	15 7/8	4 3/16	2 7/8	35	C5-35CITI-18SB	7 1/2	15 5/16	4 11/16	3 3/8	39
20	C4-35CITI-20SB	7 7/16	17 1/2	4 3/16	2 7/8	38	C5-35CITI-20SB	7 7/8	16 15/16	4 11/16	3 3/8	41
24	C4-35CITI-24SB	8 1/4	21 1/8	4 3/16	2 7/8	44	C5-35CITI-24SB	8 5/8	20 9/16	4 11/16	3 3/8	47
30	C4-35CITI-30SB	9 3/8	26 3/8	4 3/16	2 7/8	52	C5-35CITI-30SB	9 13/16	25 13/16	4 11/16	3 3/8	58
36	C4-35CITI-36SB	10 9/16	31 11/16	4 3/16	2 7/8	59	C5-35CITI-36SB	10 15/16	31 1/16	4 11/16	3 3/8	67
42	C4-35CITI-42SB	10 9/16	37 11/16	4 3/16	2 7/8	66	C5-35CITI-42SB	10 15/16	37 1/16	4 11/16	3 3/8	77
48	-	-	-	-	-	-	C5-35CITI-48SB	10 15/16	43 1/16	4 11/16	3 3/8	89
54	-	-	-	-	-	-	C5-35CITI-54SB	10 15/16	49 1/16	4 11/16	3 3/8	98
60	-	-	-	-	-	-	C5-35CITI-60SB	10 15/16	55 1/16	4 11/16	3 3/8	107

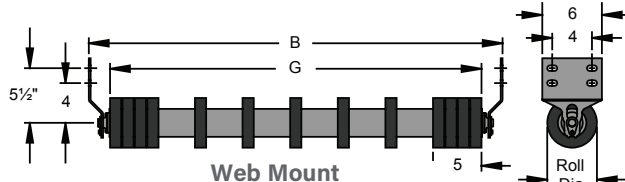
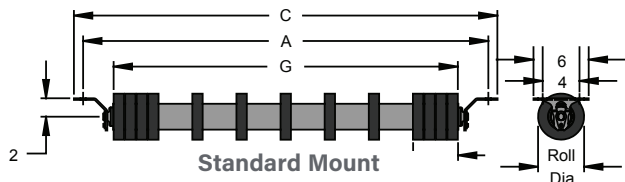

CHANNEL INSET RETURN RUBBER DISC

Belt Width	Standard Mount				Web Mount				Standard Dimensions			
	4" Roll Diameter		5" Roll Diameter		4" Roll Diameter		5" Roll Diameter					
	Part Number	WT	Part Number	WT	Part Number	WT	Part Number	WT	A	B	C	G
18	C4-CIRRD-18SB	16	C5-CIRRD-18SB	23	C4-CIRRDW-18SB	18	C5-CIRRDW-18SB	25	26	23 5/8	28	20
20	C4-CIRRD-20SB	17	C5-CIRRD-20SB	23	C4-CIRRDW-20SB	19	C5-CIRRDW-20SB	25	28	25 5/8	30	22
24	C4-CIRRD-24SB	19	C5-CIRRD-24SB	25	C4-CIRRDW-24SB	21	C5-CIRRDW-24SB	27	32	29 5/8	34	26
30	C4-CIRRD-30SB	22	C5-CIRRD-30SB	29	C4-CIRRDW-30SB	24	C5-CIRRDW-30SB	31	38	35 5/8	40	32
36	C4-CIRRD-36SB	25	C5-CIRRD-36SB	32	C4-CIRRDW-36SB	27	C5-CIRRDW-36SB	34	44	41 5/8	46	38
42	C4-CIRRD-42SB	27	C5-CIRRD-42SB	36	C4-CIRRDW-42SB	29	C5-CIRRDW-42SB	38	50	47 5/8	52	44
48	C4-CIRRD-48SB	30	C5-CIRRD-48SB	39	C4-CIRRDW-48SB	32	C5-CIRRDW-48SB	41	56	53 5/8	58	50
54*	C4-CIRRD-54SB	32	C5-CIRRD-54SB	42	C4-CIRRDW-54SB	34	C5-CIRRDW-54SB	44	62	59 5/8	64	56
60*	C4-CIRRD-60SB	35	C5-CIRRD-60SB	46	C4-CIRRDW-60SB	37	C5-CIRRDW-60SB	48	68	65 5/8	70	62

*CEMA recommends D Idlers for 54" and 60" Flat Idlers.

CEMA C CIF, LSI & IVR

CHANNEL INSET FLAT CARRIER

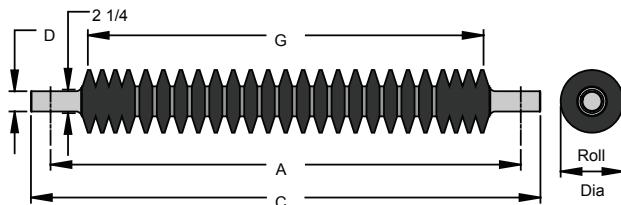
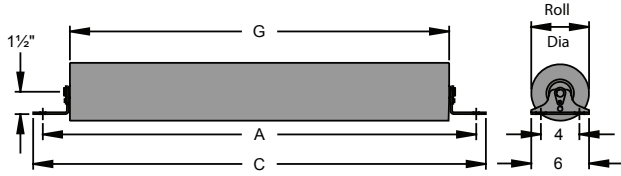

Belt Width	4" Roll Diameter		5" Roll Diameter		Standard Dimensions		
	Part Number	WT	Part Number	WT	A	C	G
18	C4-CIF-18SB	20	C5-CIF-18SB	23	26	28	20 1/2
20	C4-CIF-20SB	21	C5-CIF-20SB	25	28	30	22 1/2
24	C4-CIF-24SB	24	C5-CIF-24SB	28	32	34	26 1/2
30	C4-CIF-30SB	28	C5-CIF-30SB	32	38	40	32 1/2
36	C4-CIF-36SB	31	C5-CIF-36SB	37	44	46	38 1/2
42	C4-CIF-42SB	35	C5-CIF-42SB	42	50	52	44 1/2
48	C4-CIF-48SB	39	C5-CIF-48SB	46	56	58	50 1/2
54*	C4-CIF-54SB	43	C5-CIF-54SB	51	62	64	56 1/2
60*	C4-CIF-60SB	46	C5-CIF-60SB	55	68	70	62 1/2

*CEMA recommends D Idlers for 54" and 60" Flat Idlers.

Live Shaft Idlers are available in several different configurations, such as with different bearing journal diameters or in steel.

Please contact PPI with your requirements.

LIVE SHAFT IMPACT FLAT CARRIER

Belt Width	5" Roll Diameter			6" Roll Diameter			Standard Dimensions		
	Part# (D=17/16)	Part# (D=1 15/16)	WT	Part# (D=17/16)	Part# (D=1 15/16)	WT	A	C	G
18	C5-23LSI-18	C5-31LSI-18	44	C6-23LSI-18	C6-31LSI-18	48	27	30 3/4	19 7/8
20	C5-23LSI-20	C5-31LSI-20	48	C6-23LSI-20	C6-31LSI-20	52	29	32 3/4	21 7/8
24	C5-23LSI-24	C5-31LSI-24	54	C6-23LSI-24	C6-31LSI-24	60	33	36 3/4	25 7/8
30	C5-23LSI-30	C5-31LSI-30	64	C6-23LSI-30	C6-31LSI-30	71	39	42 3/4	31 7/8
36	C5-23LSI-36	C5-31LSI-36	74	C6-23LSI-36	C6-31LSI-36	82	45	48 3/4	37 7/8
42	C5-23LSI-42	C5-31LSI-42	84	C6-23LSI-42	C6-31LSI-42	94	51	54 3/4	43 7/8
48	C5-23LSI-48	C5-31LSI-48	94	C6-23LSI-48	C6-31LSI-48	105	57	60 3/4	49 7/8
54	C5-23LSI-54	C5-31LSI-54	104	C6-23LSI-54	C6-31LSI-54	116	63	66 3/4	55 7/8
60	C5-23LSI-60	C5-31LSI-60	114	C6-23LSI-60	C6-31LSI-60	128	69	72 3/4	61 7/8

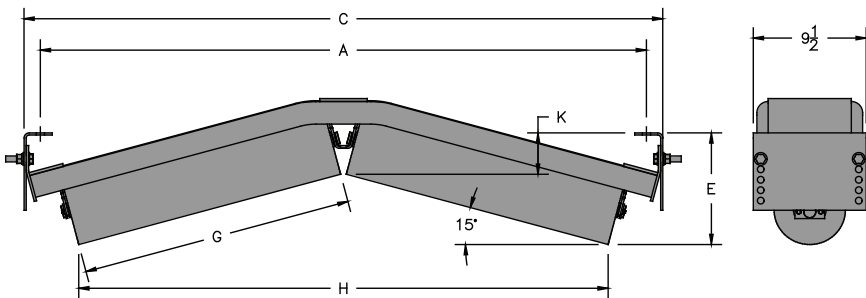

INVERTED V-RETURN

Belt Width	Standard Dimiameter		
	A	C	G
18	27	29.75	10.63
24	33	35.75	13.66
30	39	41.75	16.70
36	45	47.75	19.75
42	51	53.75	22.81
48	57	59.75	25.84
54	63	65.75	28.88
60	69	71.75	31.94
66	75	77.75	35.00

Belt Width	4" Roll Diameter					5" Roll Diameter					6" Roll Diameter				
	Part Number	E	H	K	WT	Part Number	E	H	K	WT	Part Number	E	H	K	WT
18	C4-15IVR-18SB-4	8.48	21.56	5.73	92	C5-15IVR-18SB-4	8.96	21.26	6.21	66	C6-15IVR-18SB-4	9.44	21.00	6.69	72
24	C4-15IVR-24SB-4	8.46	27.42	4.93	71	C5-15IVR-24SB-4	8.94	27.12	5.41	75	C6-15IVR-24SB-4	9.42	26.86	5.89	83
30	C4-15IVR-30SB-4	8.44	33.30	4.12	79	C5-15IVR-30SB-4	8.93	33.00	4.60	84	C6-15IVR-30SB-4	9.41	32.74	5.08	93
36	C4-15IVR-36SB-4	8.43	39.19	3.32	88	C5-15IVR-36SB-4	8.91	38.89	3.80	93	C6-15IVR-36SB-4	9.39	38.63	4.28	104
42	C4-15IVR-42SB-4	8.42	45.10	2.52	96	C5-15IVR-42SB-4	8.90	44.80	3.00	103	C6-15IVR-42SB-4	9.38	44.55	3.48	114
48	C4-15IVR-48SB-4	8.40	50.96	1.71	105	C5-15IVR-48SB-4	8.88	50.66	2.19	112	C6-15IVR-48SB-4	9.36	50.40	2.67	125
54	C4-15IVR-54SB-4	8.38	56.81	0.91	113	C5-15IVR-54SB-4	8.86	56.52	1.39	121	C6-15IVR-54SB-4	9.34	56.26	1.87	135
60	C4-15IVR-60SB-4	8.37	62.73	0.10	121	C5-15IVR-60SB-4	8.85	62.43	0.58	130	C6-15IVR-60SB-4	9.33	62.18	1.06	146
66	C4-15IVR-66SB-4	8.36	68.65	-0.70	130	C5-15IVR-66SB-4	8.84	68.35	-0.22	139	C6-15IVR-66SB-4	9.32	68.09	0.26	156

*Dimensions are for top position. There are four additional positions available.

CHANNEL INSET FLAT IMPACT

Belt Width	5" Roll Diameter		Standard Dimensions		
	Part Number	WT	A	C	G
18	C5-CIFRD-18SB	23	26	28	19
20	C5-CIFRD-20SB	23	28	30	21
24	C5-CIFRD-24SB	25	32	34	25
30	C5-CIFRD-30SB	29	38	40	31
36	C5-CIFRD-36SB	32	44	46	37
42	C5-CIFRD-42SB	36	50	52	43
48	C5-CIFRD-48SB	39	56	58	49
54*	C5-CIFRD-54SB	42	62	64	55
60*	C5-CIFRD-60SB	46	68	70	61

*CEMA recommends D Idlers for 54" and 60" Flat Idlers.

Live Shaft Idlers are available in several different configurations, such as with different bearing journal diameters or in steel.

Please contact PPI with your requirements.

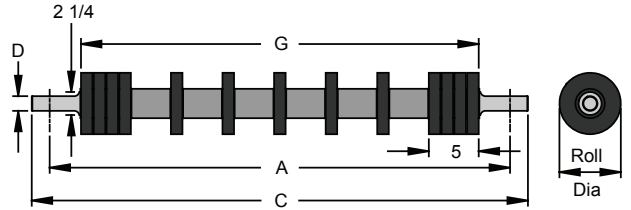
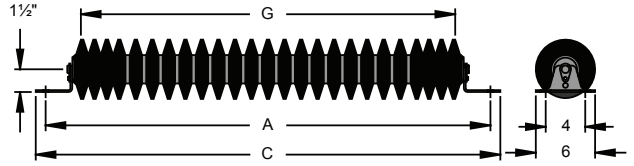

LIVE SHAFT RETURN RUBBER DISC

Belt Width	5" Roll Diameter			6" Roll Diameter			Standard Dimensions		
	Part# (D=17/16)	Part# (D=115/16)	WT	Part# (D=17/16)	Part# (D=115/16)	WT	A	C	G
18	C5-23LSRRD-18	C5-31LSRRD-18	28	C6-23LSRRD-18	C6-31LSRRD-18	33	27	30 1/2	20 7/8
20	C5-23LSRRD-20	C5-31LSRRD-20	29	C6-23LSRRD-20	C6-31LSRRD-20	33	29	32 1/2	22 7/8
24	C5-23LSRRD-24	C5-31LSRRD-24	32	C6-23LSRRD-24	C6-31LSRRD-24	37	33	36 1/2	26 7/8
30	C5-23LSRRD-30	C5-31LSRRD-30	36	C6-23LSRRD-30	C6-31LSRRD-30	42	39	42 1/2	32 7/8
36	C5-23LSRRD-36	C5-31LSRRD-36	40	C6-23LSRRD-36	C6-31LSRRD-36	46	45	48 1/2	38 7/8
42	C5-23LSRRD-42	C5-31LSRRD-42	44	C6-23LSRRD-42	C6-31LSRRD-42	50	51	54 1/2	44 7/8
48	C5-23LSRRD-48	C5-31LSRRD-48	48	C6-23LSRRD-48	C6-31LSRRD-48	55	57	60 1/2	50 7/8
54	C5-23LSRRD-54	C5-31LSRRD-54	53	C6-23LSRRD-54	C6-31LSRRD-54	59	63	66 1/2	56 7/8
60	C5-23LSRRD-60	C5-31LSRRD-60	57	C6-23LSRRD-60	C6-31LSRRD-60	64	69	72 1/2	62 7/8

Belt Width	Standard Dimensions		
	A	C	G
18	27	29.75	10.13
24	33	35.75	13.16
30	39	41.75	16.20
36	45	47.75	19.25
42	51	53.75	22.31
48	57	59.75	25.34
54	63	65.75	28.38
60	69	71.75	31.44

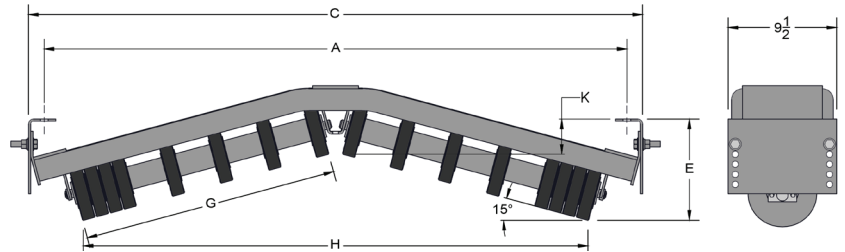

INVERTED V-RETURN RUBBER DISC

Belt Width	4" Roll Diameter					5" Roll Diameter					6" Roll Diameter				
	Part Number	E	H	K	WT	Part Number	E	H	K	WT	Part Number	E	H	K	WT
18	C415IVRI18SB-4	8.40	20.85	5.82	54	C515IVRI18SB-4	8.89	20.59	6.30	59	C615IVRI18SB-4	9.37	20.33	6.78	64
24	C415IVRI24SB-4	8.39	26.70	5.01	59	C515IVRI24SB-4	8.87	26.44	5.50	64	C615IVRI24SB-4	9.35	26.19	5.98	69
30	C415IVRI30SB-4	8.37	32.59	4.21	65	C515IVRI30SB-4	8.85	32.33	4.69	71	C615IVRI30SB-4	9.34	32.07	5.17	77
36	C415IVRI36SB-4	8.35	38.48	3.41	70	C515IVRI36SB-4	8.84	38.22	3.89	76	C615IVRI36SB-4	9.32	37.96	4.37	82
42	C415IVRI42SB-4	8.34	44.39	2.60	76	C515IVRI42SB-4	8.83	44.13	3.08	83	C615IVRI42SB-4	9.31	43.87	3.57	89
48	C415IVRI48SB-4	8.32	50.25	1.80	81	C515IVRI48SB-4	8.81	49.99	2.28	87	C615IVRI48SB-4	9.29	49.73	2.76	94
54	C415IVRI54SB-4	8.31	56.10	0.99	86	C515IVRI54SB-4	8.79	55.85	1.48	94	C615IVRI54SB-4	9.27	55.59	1.96	102
60	C415IVRI60SB-4	8.29	62.02	0.19	92	C515IVRI60SB-4	8.78	61.76	0.67	101	C615IVRI60SB-4	9.26	61.50	1.16	109

*Dimensions are for top position. There are four additional positions available.

CEMA C SELF-ALIGNER – TROUGHING IDLER

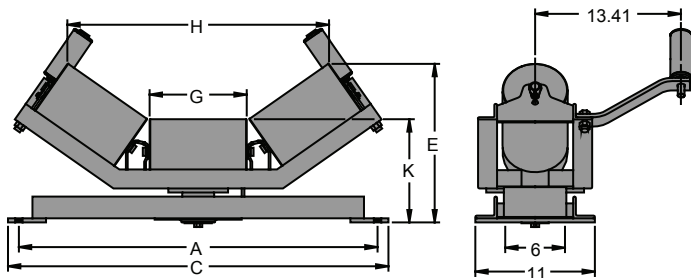

Belt Width	Standard Dimensions			Roll Height "K"			Wide Base	
	A	C	G	4"	5"	6"	Aw	Cw
18	27	29	6 3/4	8 1/2	9	9 1/2	33	35
20	29	31	7 5/8	8 1/2	9	9 1/2	35	37
24	33	35	8 15/16	8 1/2	9	9 1/2	39	41
30	39	41	11 1/8	8 1/2	9	9 1/2	45	47
36	45	47	13 1/4	8 1/2	9	9 1/2	51	53
42	51	53	15 7/16	9	9 1/2	10	57	59
48	57	59	17 5/8	9	9 1/2	10	63	65
54	63	65	19 3/4	9	9 1/2	10	69	71
60	69	71	21 3/4	9	9 1/2	10	75	77

20° SELF-ALIGNER EQUAL TROUGHING IDLER

Belt Width	4" Roll Diameter				5" Roll Diameter				6" Roll Diameter			
	Part Number	E	H	WT	Part Number	E	H	WT	Part Number	E	H	WT
18	C4-20TESA-18SB	10 15/16	21 1/16	90	C5-20TESA-18SB	11 7/16	20 11/16	94	C6-20TESA-18SB	11 7/8	20 3/8	102
20	C4-20TESA-20SB	11 1/4	23 9/16	94	C5-20TESA-20SB	11 3/4	23 1/4	98	C6-20TESA-20SB	12 3/16	22 7/8	107
24	C4-20TESA-24SB	11 11/16	27 3/8	100	C5-20TESA-24SB	12 3/16	27 1/16	105	C6-20TESA-24SB	12 5/8	26 11/16	115
30	C4-20TESA-30SB	12 1/2	33 5/8	111	C5-20TESA-30SB	12 15/16	33 3/8	116	C6-20TESA-30SB	13 7/16	32 15/16	127
36	C4-20TESA-36SB	13 3/16	39 3/4	121	C5-20TESA-36SB	13 11/16	39 7/16	127	C6-20TESA-36SB	14 1/8	39 1/8	140
42	C4-20TESA-42SB	14 7/16	46 1/16	148	C5-20TESA-42SB	14 15/16	45 3/4	155	C6-20TESA-42SB	15 3/8	45 7/16	169
48	C4-20TESA-48SB	15 3/16	52 3/8	161	C5-20TESA-48SB	15 11/16	52 1/16	169	C6-20TESA-48SB	16 1/8	51 3/4	184
54	C4-20TESA-54SB	15 15/16	58 1/2	173	C5-20TESA-54SB	16 3/8	58 3/16	182	C6-20TESA-54SB	16 7/8	57 13/16	199
60	C4-20TESA-60SB	16 9/16	64 1/4	185	C5-20TESA-60SB	17 1/16	63 7/8	194	C6-20TESA-60SB	17 1/2	63 9/16	213

35° SELF-ALIGNER EQUAL TROUGHING IDLER

Belt Width	4" Roll Diameter				5" Roll Diameter				6" Roll Diameter			
	Part Number	E	H	WT	Part Number	E	H	WT	Part Number	E	H	WT
18	C4-35TESA-18SB	12 5/8	19 3/8	94	C5-35TESA-18SB	13 1/16	18 13/16	97	C6-35TESA-18SB	13 9/16	18 1/4	106
20	C4-35TESA-20SB	13 1/8	21 11/16	98	C5-35TESA-20SB	13 9/16	21 1/8	101	C6-35TESA-20SB	14	20 9/16	111
24	C4-35TESA-24SB	13 7/8	25 1/8	104	C5-35TESA-24SB	14 5/16	24 9/16	108	C6-35TESA-24SB	14 3/4	24 1/16	118
30	C4-35TESA-30SB	15 1/8	30 15/16	114	C5-35TESA-30SB	15 9/16	30 3/8	119	C6-35TESA-30SB	16 1/16	29 13/16	131
36	C4-35TESA-36SB	16 5/16	36 1/2	124	C5-35TESA-36SB	16 3/4	35 15/16	130	C6-35TESA-36SB	17 3/16	35 7/16	143
42	C4-35TESA-42SB	18 1/8	42 5/16	153	C5-35TESA-42SB	18 9/16	41 3/4	159	C6-35TESA-42SB	18 15/16	41 3/16	174
48	C4-35TESA-48SB	19 3/8	48 1/16	165	C5-35TESA-48SB	19 13/16	47 1/2	173	C6-35TESA-48SB	20 3/16	46 15/16	188
54	C4-35TESA-54SB	20 5/8	53 11/16	177	C5-35TESA-54SB	21	53 1/8	186	C6-35TESA-54SB	21 7/16	52 9/16	203
60	C4-35TESA-60SB	21 3/4	58 15/16	189	C5-35TESA-60SB	22 3/16	58 3/8	198	C6-35TESA-60SB	22 9/16	57 7/8	217

45° SELF-ALIGNER EQUAL TROUGHING IDLER

Belt Width	4" Roll Diameter				5" Roll Diameter				6" Roll Diameter			
	Part Number	E	H	WT	Part Number	E	H	WT	Part Number	E	H	WT
18	C4-45TESA-18SB	13 11/16	18 1/8	94	C5-45TESA-18SB	13 7/8	17 1/2	98	C6-45TESA-18SB	14 3/8	16 13/16	106
20	C4-45TESA-20SB	14 1/4	20 5/16	98	C5-45TESA-20SB	14 1/2	19 5/8	102	C6-45TESA-20SB	15	18 15/16	111
24	C4-45TESA-24SB	15 3/16	23 3/8	104	C5-45TESA-24SB	15 3/8	22 3/4	109	C6-45TESA-24SB	15 7/8	22 1/8	119
30	C4-45TESA-30SB	16 3/4	28 11/16	115	C5-45TESA-30SB	16 15/16	28 1/16	120	C6-45TESA-30SB	17 1/2	27 3/8	131
36	C4-45TESA-36SB	18 1/4	33 7/8	125	C5-45TESA-36SB	18 7/16	33 1/8	131	C6-45TESA-36SB	18 15/16	32 5/16	143
42	C4-45TESA-42SB	20 5/16	39 1/8	153	C5-45TESA-42SB	20 7/16	38 7/16	160	C6-45TESA-42SB	21	37 11/16	175
48	C4-45TESA-48SB	21 7/8	44 7/16	166	C5-45TESA-48SB	22	43 11/16	174	C6-45TESA-48SB	22 9/16	43 1/16	189
54	C4-45TESA-54SB	23 3/8	49 9/16	178	C5-45TESA-54SB	23 11/16	48 13/16	187	C6-45TESA-54SB	24 1/16	48 1/16	204
60	C4-45TESA-60SB	24 3/4	54 3/8	190	C5-45TESA-60SB	25 1/8	53 11/16	199	C6-45TESA-60SB	25 7/16	53	218

CEMA C SELF-ALIGNER RETURN & FLAT

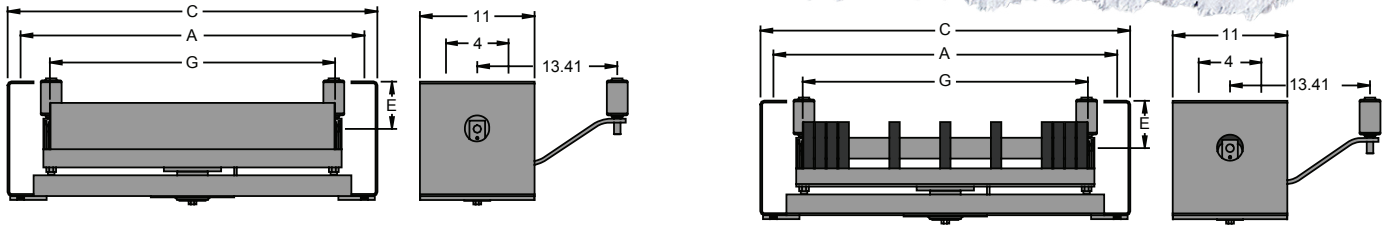

RETURN SELF-ALIGNER

Belt Width	4" Roll Diameter		5" Roll Diameter		6" Roll Diameter		Standard Dimensions				Wide Base	
	Part Number	WT	Part Number	WT	Part Number	WT	A	C	E	G	Aw	Cw
18	C4-RSA-18SB	96	C5-RSA-18SB	100	C6-RSA-18SB	106	27	29	4 1/2	21 3/8	33	35
20	C4-RSA-20SB	100	C5-RSA-20SB	103	C6-RSA-20SB	110	29	31	4 1/2	23 3/8	35	37
24	C4-RSA-24SB	106	C5-RSA-24SB	110	C6-RSA-24SB	117	33	35	4 1/2	27 3/8	39	41
30	C4-RSA-30SB	116	C5-RSA-30SB	121	C6-RSA-30SB	129	39	41	4 1/2	33 3/8	45	47
36	C4-RSA-36SB	126	C5-RSA-36SB	131	C6-RSA-36SB	141	45	47	4 1/2	39 3/8	51	53
42	C4-RSA-42SB	141	C5-RSA-42SB	147	C6-RSA-42SB	159	51	53	4 1/2	45 3/8	57	59
48	C4-RSA-48SB	153	C5-RSA-48SB	160	C6-RSA-48SB	172	57	59	4 1/2	51 3/8	63	65
54*	C4-RSA-54SB	163	C5-RSA-54SB	171	C6-RSA-54SB	185	63	65	4 1/2	57 3/8	69	71
60*	C4-RSA-60SB	174	C5-RSA-60SB	182	C6-RSA-60SB	197	69	71	4 1/2	63 3/8	75	77

RETURN RUBBER DISC SELF-ALIGNER

Belt Width	4" Roll Diameter		5" Roll Diameter		6" Roll Diameter		Standard Dimensions				Wide Base	
	Part Number	WT	Part Number	WT	Part Number	WT	A	C	E	G	Aw	Cw
18	C4-RRDSA-18SB	96	C5-RRDSA-18SB	99	C6-RRDSA-18SB	103	27	29	4 1/2	20 7/8	33	35
20	C4-RRDSA-20SB	99	C5-RRDSA-20SB	102	C6-RRDSA-20SB	106	29	31	4 1/2	22 7/8	35	37
24	C4-RRDSA-24SB	105	C5-RRDSA-24SB	108	C6-RRDSA-24SB	113	33	35	4 1/2	26 7/8	39	41
30	C4-RRDSA-30SB	113	C5-RRDSA-30SB	117	C6-RRDSA-30SB	122	39	41	4 1/2	32 7/8	45	47
36	C4-RRDSA-36SB	122	C5-RRDSA-36SB	127	C6-RRDSA-36SB	132	45	47	4 1/2	38 7/8	51	53
42	C4-RRDSA-42SB	137	C5-RRDSA-42SB	141	C6-RRDSA-42SB	148	51	53	4 1/2	44 7/8	57	59
48	C4-RRDSA-48SB	147	C5-RRDSA-48SB	152	C6-RRDSA-48SB	159	57	59	4 1/2	50 7/8	63	65
54*	C4-RRDSA-54SB	157	C5-RRDSA-54SB	162	C6-RRDSA-54SB	169	63	65	4 1/2	56 7/8	69	71
60*	C4-RRDSA-60SB	167	C5-RRDSA-60SB	172	C6-RRDSA-60SB	179	69	71	4 1/2	62 7/8	75	77

*CEMA recommends D Idlers for 54" and 60" Flat Idlers. RSAs & RRDSAs are available with 1 1/2" drop (E). To specify 1 1/2" drop, add "-1" to end of part number

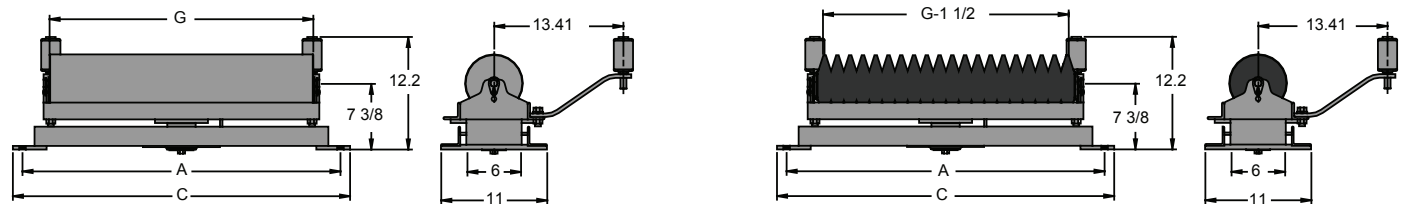

FLAT CARRIER SELF-ALIGNER

Belt Width	Steel Rolls						Rubber Disc Rolls				Standard Dimensions		Wide Base		
	4" Roll Diameter		5" Roll Diameter		6" Roll Diameter		5" Roll Diameter		6" Roll Diameter						
	Part Number	WT	Part Number	WT	Part Number	WT	Part Number	WT	Part Number	WT					
18	C4-FSA-18SB	80	C5-FSA-18SB	83	C6-FSA-18SB	89	C5-FRDSA-18SB	89	C6-FRDSA-18SB	95	27	29	21 3/8	33	35
20	C4-FSA-20SB	84	C5-FSA-20SB	87	C6-FSA-20SB	93	C5-FRDSA-20SB	93	C6-FRDSA-20SB	99	29	31	23 3/8	35	37
24	C4-FSA-24SB	90	C5-FSA-24SB	94	C6-FSA-24SB	101	C5-FRDSA-24SB	102	C6-FRDSA-24SB	109	33	35	27 3/8	39	41
30	C4-FSA-30SB	100	C5-FSA-30SB	104	C6-FSA-30SB	113	C5-FRDSA-30SB	114	C6-FRDSA-30SB	123	39	41	33 3/8	45	47
36	C4-FSA-36SB	110	C5-FSA-36SB	115	C6-FSA-36SB	125	C5-FRDSA-36SB	127	C6-FRDSA-36SB	137	45	47	39 3/8	51	53
42	C4-FSA-42SB	126	C5-FSA-42SB	132	C6-FSA-42SB	143	C5-FRDSA-42SB	146	C6-FRDSA-42SB	157	51	53	45 3/8	57	59
48	C4-FSA-48SB	136	C5-FSA-48SB	143	C6-FSA-48SB	156	C5-FRDSA-48SB	159	C6-FRDSA-48SB	172	57	59	51 3/8	63	65
54*	C4-FSA-54SB	147	C5-FSA-54SB	155	C6-FSA-54SB	169	C5-FRDSA-54SB	172	C6-FRDSA-54SB	187	63	65	57 3/8	69	71
60*	C4-FSA-60SB	157	C5-FSA-60SB	166	C6-FSA-60SB	181	C5-FRDSA-60SB	186	C6-FRDSA-60SB	202	69	71	63 3/8	75	77

*CEMA recommends D Idlers for 54" and 60" Flat Idlers.

CEMA D CLASS IDLERS

CEMA D CLASS IDLERS PRODUCT OFFERINGS

- Equal Troughing Idler
- Equal Impact Troughing Idler
- Unequal Troughing Idler
- Unequal Impact Troughing Idler
- Flat Carrier
- Impact Flat Carrier
- Return Roller
- Return Rubber Disc
- Channel Inset Flat Carrier
- Channel Inset Flat Rubber Disc Carrier
- Channel Inset Troughing Idler
- Channel Inset Return Roller
- Channel Inset Impact Troughing Idler
- Channel Inset Impact Return Roller
- Self-Aligner Troughing Idler
- Self-Aligner Return Roller
- Self-Aligner Flat Roller
- Additional Configurations Available

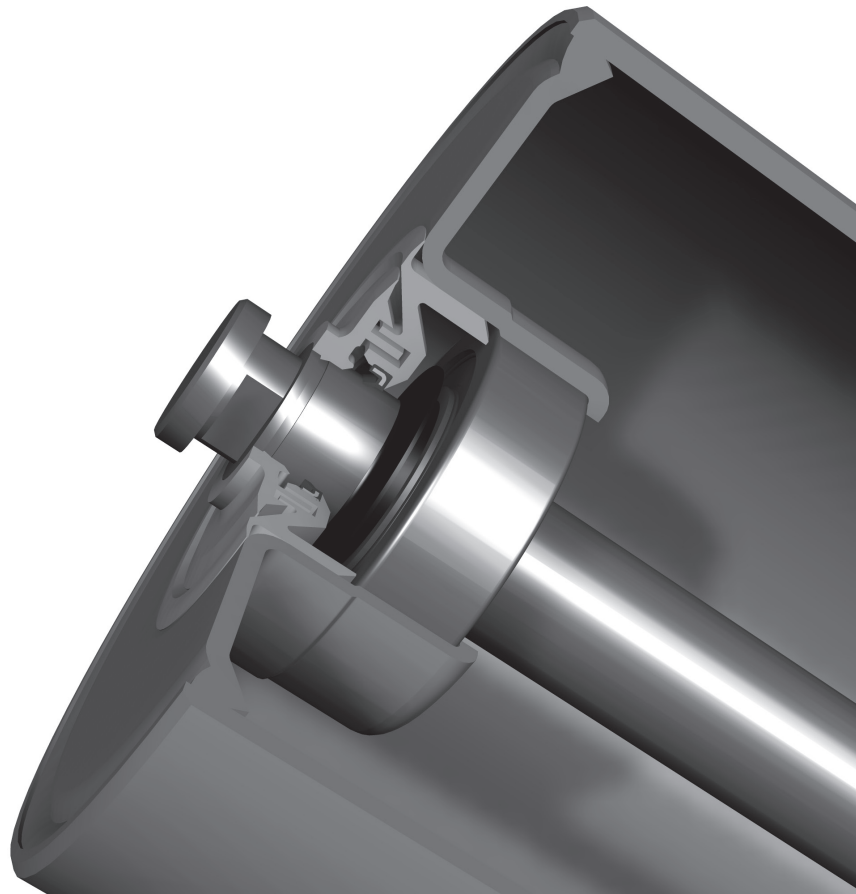

CEMA D LOAD RATINGS

BELT WIDTH	TROUGHING ANGLE			RETURN & FLAT	TWO-ROLL V-RETURNS	UNEQUAL (Picking)	LIVE SHAFT
	20°	35°	45°				
18	1,200	1,200	1,200	600	850	600	1,400
24	1,200	1,200	1,200	600	850	600	1,400
30	1,200	1,200	1,200	600	850	600	1,400
36	1,200	1,200	1,200	600	850	600	1,400
42	1,200	1,200	1,200	500	850	600	1,400
48	1,200	1,200	1,200	425	850	530	1,275
54	1,200	1,116	1,080	375	850	440	1,150
60	1,150	1,070	1,035	280	850	400	1,000
66	-	-	-	215	850	-	-
72	1,050	977	945	155	850	280	850
78	-	-	-	125	850	-	-

CEMA D EQUAL TROUGHING IDLERS

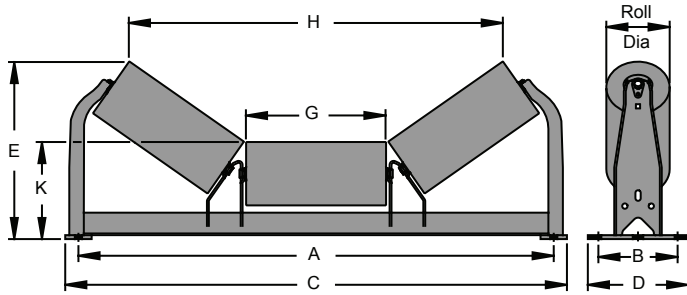

Belt Width	Standard Dimensions					Wide Base	
	A	B	C	D	G	Aw	Cw
24	33	6	35	8	8 15/16	39	41
30	39	6	41 1/2	9 1/2	11 1/8	45	47 1/2
36	45	6	47 1/2	9 1/2	13 1/4	51	53 1/2
42	51	7 1/2	53 1/2	9 1/2	15 7/16	57	59 1/2
48	57	7 1/2	59 1/2	9 1/2	17 5/8	63	65 1/2
54	63	9	65 1/2	10 15/16	19 3/4	69	71 1/2
60	69	9	71 1/2	10 15/16	21 3/4	75	77 1/2
72	81	9	83 1/2	11	26	87	89 1/2

20° EQUAL TROUGHING IDLER

Belt Width	5" Roll Diameter					6" Roll Diameter				
	Part Number	E	H	K	WT	Part Number	E	H	K	WT
24	D5-20TE-24SB	11 11/16	27 1/16	8 1/2	48	D6-20TE-24SB	12 1/8	26 11/16	9	56
30	D5-20TE-30SB	12 9/16	33 3/8	8 5/8	58	D6-20TE-30SB	13 1/16	32 15/16	9 1/8	66
36	D5-20TE-36SB	13 5/16	39 7/16	8 5/8	65	D6-20TE-36SB	13 3/4	39 1/8	9 1/8	75
42	D5-20TE-42SB	14 7/16	45 3/4	9	82	D6-20TE-42SB	14 7/8	45 7/16	9 1/2	93
48	D5-20TE-48SB	15 3/16	52 1/16	9	91	D6-20TE-48SB	15 5/8	51 3/4	9 1/2	103
54	D5-20TE-54SB	16 1/4	58 3/16	9 1/2	105	D6-20TE-54SB	16 3/4	57 13/16	10	118
60	D5-20TE-60SB	16 7/8	63 7/8	9 1/2	113	D6-20TE-60SB	17 3/8	63 9/16	10	128
72	D5-20TE-72SB	18 3/8	76 3/16	9 1/2	127	D6-20TE-72SB	18 7/8	75 13/16	10	147

35° EQUAL TROUGHING IDLER

Belt Width	5" Roll Diameter					6" Roll Diameter				
	Part Number	E	H	K	WT	Part Number	E	H	K	WT
24	D5-35TE-24SB	13 13/16	24 9/16	8 1/2	50	D6-35TE-24SB	14 1/4	24 1/16	9	57
30	D5-35TE-30SB	15 3/16	30 3/8	8 5/8	59	D6-35TE-30SB	15 11/16	29 13/16	9 1/8	68
36	D5-35TE-36SB	16 3/8	35 15/16	8 5/8	67	D6-35TE-36SB	16 13/16	35 7/16	9 1/8	76
42	D5-35TE-42SB	18 1/16	41 3/4	9	85	D6-35TE-42SB	18 7/16	41 3/16	9 1/2	96
48	D5-35TE-48SB	19 5/16	47 1/2	9	94	D6-35TE-48SB	19 11/16	46 15/16	9 1/2	106
54	D5-35TE-54SB	20 7/8	53 1/8	9 1/2	111	D6-35TE-54SB	21 5/16	52 9/16	10	125
60	D5-35TE-60SB	22 1/16	58 3/8	9 1/2	119	D6-35TE-60SB	22 7/16	57 7/8	10	134
72	D5-35TE-72SB	24 7/16	69 9/16	9 1/2	136	D6-35TE-72SB	24 7/8	69 1/16	10	157

45° EQUAL TROUGHING IDLER

Belt Width	5" Roll Diameter					6" Roll Diameter				
	Part Number	E	H	K	WT	Part Number	E	H	K	WT
24	D5-45TE-24SB	15 1/16	22 3/4	8 1/2	50	D6-45TE-24SB	15 3/8	22 1/8	9	58
30	D5-45TE-30SB	16 3/4	28 1/16	8 5/8	60	D6-45TE-30SB	17 1/8	27 3/8	9 1/8	69
36	D5-45TE-36SB	18 3/16	33 1/8	8 5/8	68	D6-45TE-36SB	18 9/16	32 5/16	9 1/8	78
42	D5-45TE-42SB	20 3/16	38 7/16	9	85	D6-45TE-42SB	20 1/2	37 11/16	9 1/2	96
48	D5-45TE-48SB	21 11/16	43 11/16	9	97	D6-45TE-48SB	22 1/16	43 1/16	9 1/2	109
54	D5-45TE-54SB	23 9/16	48 13/16	9 1/2	113	D6-45TE-54SB	23 15/16	48 1/16	10	126
60	D5-45TE-60SB	25	53 11/16	9 1/2	120	D6-45TE-60SB	25 5/16	53	10	135
72	D5-45TE-72SB	28	63 15/16	9 1/2	138	D6-45TE-72SB	28 5/16	63 1/4	10	159

CEMA D EQUAL IMPACT TROUGHING IDLERS

Belt Width	Standard Dimensions					Wide Base	
	A	B	C	D	G	Aw	Cw
24	33	6	35	8	7 7/16	39	41
30	39	6	41 1/2	9 1/2	9 5/8	45	47 1/2
36	45	6	47 1/2	9 1/2	11 3/4	51	53 1/2
42	51	7 1/2	53 1/2	9 1/2	13 15/16	57	59 1/2
48	57	7 1/2	59 1/2	9 1/2	16 1/8	63	65 1/2
54	63	9	65 1/2	10 15/16	18 1/4	69	71 1/2
60	69	9	71 1/2	10 15/16	20 1/4	75	77 1/2
72	81	9	83 1/2	11	24 1/4	87	89 1/2

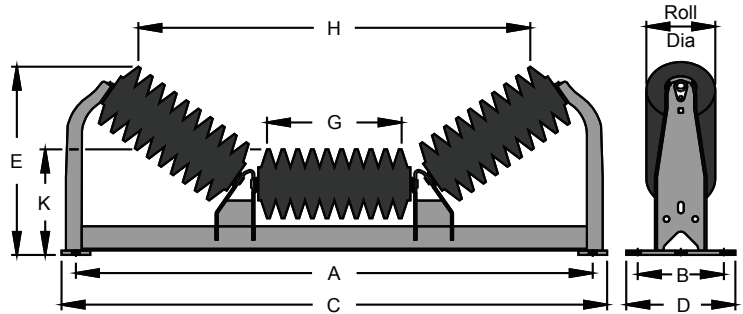

20° EQUAL IMPACT TROUGHING IDLER

Belt Width	5" Roll Diameter					6" Roll Diameter				
	Part Number	E	H	K	WT	Part Number	E	H	K	WT
24	D5-20TEI-24SB	11 7/16	26 5/8	8 1/2	61	D6-20TEI-24SB	11 7/8	26 1/4	9	68
30	D5-20TEI-30SB	12 5/16	32 15/16	8 5/8	75	D6-20TEI-30SB	12 13/16	32 1/2	9 1/8	84
36	D5-20TEI-36SB	13 1/16	39	8 5/8	88	D6-20TEI-36SB	13 1/2	38 11/16	9 1/8	99
42	D5-20TEI-42SB	14 3/16	45 5/16	9	110	D6-20TEI-42SB	14 5/8	45	9 1/2	124
48	D5-20TEI-48SB	14 15/16	51 5/8	9	122	D6-20TEI-48SB	15 3/8	51 1/4	9 1/2	137
54	D5-20TEI-54SB	16	57 11/16	9 1/2	140	D6-20TEI-54SB	16 1/2	57 3/8	10	157
60	D5-20TEI-60SB	16 5/8	63 7/16	9 1/2	153	D6-20TEI-60SB	17 1/8	63 1/8	10	173
72	D5-20TEI-72SB	18 1/8	75 3/4	9 1/2	181	D6-20TEI-72SB	18 5/8	75 3/8	10	199

35° EQUAL IMPACT TROUGHING IDLER

Belt Width	5" Roll Diameter					6" Roll Diameter				
	Part Number	E	H	K	WT	Part Number	E	H	K	WT
24	D5-35TEI-24SB	13 3/8	24 3/16	8 1/2	62	D6-35TEI-24SB	13 13/16	23 5/8	9	69
30	D5-35TEI-30SB	14 3/4	29 15/16	8 5/8	77	D6-35TEI-30SB	15 1/8	29 3/8	9 1/8	86
36	D5-35TEI-36SB	15 15/16	35 9/16	8 5/8	90	D6-35TEI-36SB	16 3/8	35	9 1/8	101
42	D5-35TEI-42SB	17 5/8	41 3/8	9	113	D6-35TEI-42SB	18	40 3/4	9 1/2	127
48	D5-35TEI-48SB	18 7/8	47 1/8	9	125	D6-35TEI-48SB	19 1/4	46 1/2	9 1/2	140
54	D5-35TEI-54SB	20 7/16	52 3/4	9 1/2	147	D6-35TEI-54SB	20 7/8	52 1/8	10	164
60	D5-35TEI-60SB	21 5/8	58	9 1/2	160	D6-35TEI-60SB	22	57 3/8	10	179
72	D5-35TEI-72SB	24	69 3/16	9 1/2	190	D6-35TEI-72SB	24 7/16	68 5/8	10	208

45° EQUAL IMPACT TROUGHING IDLER

Belt Width	5" Roll Diameter					6" Roll Diameter				
	Part Number	E	H	K	WT	Part Number	E	H	K	WT
24	D5-45TEI-24SB	14 9/16	22 3/8	8 1/2	63	D6-45TEI-24SB	14 7/8	21 11/16	9	70
30	D5-45TEI-30SB	16 1/4	27 5/8	8 5/8	78	D6-45TEI-30SB	16 9/16	26 15/16	9 1/8	87
36	D5-45TEI-36SB	17 11/16	32 3/4	8 5/8	91	D6-45TEI-36SB	18 1/16	32 1/16	9 1/8	102
42	D5-45TEI-42SB	19 11/16	38 1/16	9	113	D6-45TEI-42SB	20	37 3/8	9 1/2	127
48	D5-45TEI-48SB	21 3/16	43 1/3	9	128	D6-45TEI-48SB	21 9/16	42 5/8	9 1/2	143
54	D5-45TEI-54SB	23 1/16	48 7/16	9 1/2	148	D6-45TEI-54SB	23 7/16	47 3/4	10	165
60	D5-45TEI-60SB	24 1/2	53 1/4	9 1/2	160	D6-45TEI-60SB	24 13/16	52 9/16	10	180
72	D5-45TEI-72SB	27 1/2	63 9/16	9 1/2	193	D6-45TEI-72SB	27 13/16	62 13/16	10	210

CEMA D UNEQUAL TROUGHING & FLAT CARRIER IDLERS

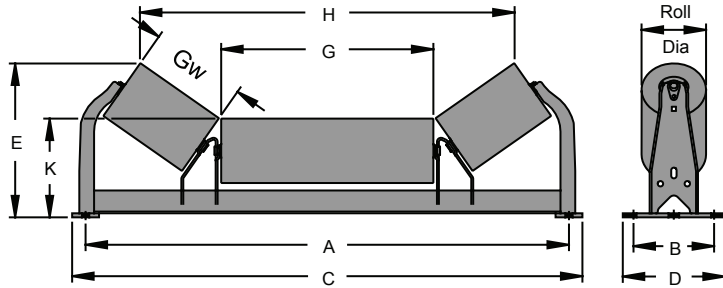

Belt Width	Standard Dimensions			
	A	B	C	D
24	33	6	35 1/2	8
30	39	6	41 1/2	9 1/2
36	45	6	47 1/2	9 1/2
42	51	7 1/2	53 1/2	9 1/2
48	57	7 1/2	59 1/2	9 1/2
54	63	9	65 1/2	10 15/16
60	69	9	71 1/2	10 15/16
72	81	9	83 1/2	10 15/16

20° UNEQUAL TROUGHING IDLER

Belt Width	5" Roll Diameter					6" Roll Diameter					G	Gw
	Part Number	E	H	K	WT	Part Number	E	H	K	WT		
24	D5-20TU-24SB	10 5/8	26 15/16	8 5/8	49	D6-20TU-24SB	11 1/16	26 5/8	9 1/8	57	15 7/16	5 7/16
30	D5-20TU-30SB	10 5/8	32 7/8	8 5/8	56	D6-20TU-30SB	11 1/16	32 9/16	9 1/8	64	21 3/8	5 7/16
36	D5-20TU-36SB	10 5/8	38 7/8	8 5/8	62	D6-20TU-36SB	11 1/16	38 9/16	9 1/8	72	27 3/8	5 7/16
42	D5-20TU-42SB	11	44 7/8	9	78	D6-20TU-42SB	11 7/16	44 9/16	9 1/2	88	33 3/8	5 7/16
48	D5-20TU-48SB	11	50 7/8	9	85	D6-20TU-48SB	11 7/16	50 9/16	9 1/2	97	39 3/8	5 7/16
54	D5-20TU-54SB	11 3/8	56 7/8	9 1/2	98	D6-20TU-54SB	11 13/16	56 9/16	10	111	45 3/8	5 7/16
60	D5-20TU-60SB	11 3/8	62 7/8	9 1/2	106	D6-20TU-60SB	11 13/16	62 9/16	10	120	51 3/8	5 7/16
72	D5-20TU-72SB	11 3/8	74 7/8	9 1/2	122	D6-20TU-72SB	11 13/16	74 9/16	10	139	63 3/8	5 7/16

35° UNEQUAL TROUGHING IDLER

Belt Width	5" Roll Diameter					6" Roll Diameter					G	Gw
	Part Number	E	H	K	WT	Part Number	E	H	K	WT		
24	D5-35TU-24SB	12 3/4	25 5/16	8 5/8	50	D6-35TU-24SB	12 3/16	24 3/4	9 1/8	59	13 1/4	6 3/4
30	D5-35TU-30SB	13 15/16	31 1/16	8 5/8	57	D6-35TU-30SB	14 5/16	30 9/16	9 1/8	67	15 7/16	8 15/16
36	D5-35TU-36SB	13 15/16	35 3/8	8 5/8	62	D6-35TU-36SB	14 5/16	34 7/8	9 1/8	73	19 3/4	8 15/16
42	D5-35TU-42SB	15 9/16	40 5/8	9	77	D6-35TU-42SB	15 15/16	40 1/16	9 1/2	90	21 3/8	11 1/8
48	D5-35TU-48SB	15 9/16	46 5/8	9	85	D6-35TU-48SB	15 15/16	46 1/16	9 1/2	99	27 3/8	11 1/8
54	D5-35TU-54SB	15 15/16	52 5/8	9 1/2	98	D6-35TU-54SB	16 5/16	52 1/16	10	112	33 3/8	11 1/8
60	D5-35TU-60SB	15 15/16	58 5/8	9 1/2	105	D6-35TU-60SB	16 5/16	58 1/16	10	121	39 3/8	11 1/8
72	D5-35TU-72SB	15 15/16	70 5/8	9 1/2	122	D6-35TU-72SB	16 5/16	70 1/16	10	140	51 3/8	11 1/8

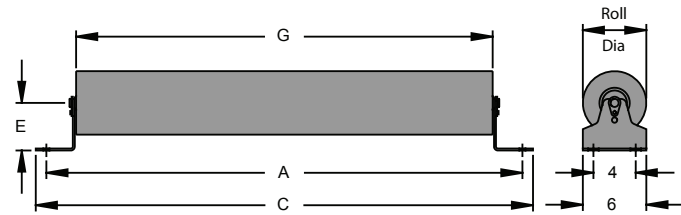

FLAT CARRIER

Belt Width	5" Roll Diameter				6" Roll Diameter				Standard Dimensions		
	E=4 1/2"		E=1 1/2"		E=4 1/2"		E=1 1/2"				
	Part Number	WT	Part Number	WT	Part Number	WT	Part Number	WT	A	C	G
24	D5-F-24SB	31	D5-F-24SB-1	30	D6-F-24SB	37	D6-F-24SB-1	36	33	35	27 3/8
30	D5-F-30SB	36	D5-F-30SB-1	35	D6-F-30SB	43	D6-F-30SB-1	42	39	41	33 3/8
36	D5-F-36SB	41	D5-F-36SB-1	40	D6-F-36SB	49	D6-F-36SB-1	48	45	47	39 3/8
42	D5-F-42SB	46	D5-F-42SB-1	45	D6-F-42SB	55	D6-F-42SB-1	54	51	53	45 3/8
48	D5-F-48SB	50	D5-F-48SB-1	49	D6-F-48SB	61	D6-F-48SB-1	60	57	59	51 3/8
54	D5-F-54SB	55	D5-F-54SB-1	54	D6-F-54SB	67	D6-F-54SB-1	66	63	65	57 3/8
60	D5-F-60SB	60	D5-F-60SB-1	59	D6-F-60SB	72	D6-F-60SB-1	71	69	71	63 3/8
72	D5-F-72SB	69	D5-F-72SB-1	68	D6-F-72SB	84	D6-F-72SB-1	83	81	83	75 3/8

CEMA D UNEQUAL IMPACT TROUGHING & FLAT CARRIER IDLERS

Belt Width	Standard Dimensions			
	A	B	C	D
24	33	6	35 1/2	8
30	39	6	41 1/2	9 1/2
36	45	6	47 1/2	9 1/2
42	51	7 1/2	53 1/2	9 1/2
48	57	7 1/2	59 1/2	9 1/2
54	63	9	65 1/2	10 15/16
60	69	9	71 1/2	10 15/16
72	81	9	83 1/2	10 15/16

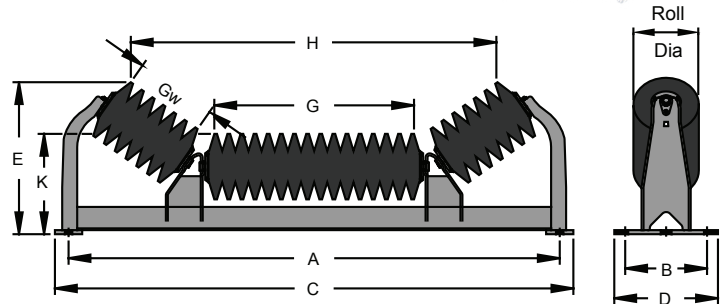

20° UNEQUAL IMPACT TROUGHING IDLER

Belt Width	5" Roll Diameter					6" Roll Diameter					G	Gw
	Part Number	E	H	K	WT	Part Number	E	H	K	WT		
24	D5-20TUI-24SB	10 3/8	26 1/2	8 5/8	64	D6-20TUI-24SB	10 13/16	26 3/16	9 1/8	71	13 15/16	3 15/16
30	D5-20TUI-30SB	10 3/8	32 7/16	8 5/8	73	D6-20TUI-30SB	10 13/16	32 1/8	9 1/8	84	19 7/8	3 15/16
36	D5-20TUI-36SB	10 3/8	38 7/16	8 5/8	84	D6-20TUI-36SB	10 13/16	37 1/8	9 1/8	94	25 7/8	3 15/16
42	D5-20TUI-42SB	10 3/4	44 7/16	9	103	D6-20TUI-42SB	11 3/16	43 1/8	9 1/2	114	31 7/8	3 15/16
48	D5-20TUI-48SB	10 3/4	50 7/16	9	112	D6-20TUI-48SB	11 3/16	49 1/8	9 1/2	124	37 7/8	3 15/16
54	D5-20TUI-54SB	11 1/8	56 7/16	9 1/2	130	D6-20TUI-54SB	11 9/16	55 1/8	10	144	43 7/8	3 15/16
60	D5-20TUI-60SB	11 1/8	62 7/16	9 1/2	141	D6-20TUI-60SB	11 9/16	61 1/8	10	157	49 7/8	3 15/16
72	D5-20TUI-72SB	11 1/8	74 7/16	9 1/2	165	D6-20TUI-72SB	11 9/16	73 1/8	10	186	61 7/8	3 15/16

35° UNEQUAL IMPACT TROUGHING IDLER

Belt Width	5" Roll Diameter					6" Roll Diameter					G	Gw
	Part Number	E	H	K	WT	Part Number	E	H	K	WT		
24	D5-35TUI-24SB	12 5/16	24 7/8	8 5/8	66	D6-35TUI-24SB	11 3/4	24 3/8	9 1/8	73	11 3/4	5 1/4
30	D5-35TUI-30SB	13 1/2	30 11/16	8 5/8	77	D6-35TUI-30SB	13 7/8	30 1/8	9 1/8	86	13 15/16	7 7/16
36	D5-35TUI-36SB	13 1/2	35	8 5/8	85	D6-35TUI-36SB	13 7/8	34 1/2	9 1/8	95	18 1/4	7 7/16
42	D5-35TUI-42SB	15 1/8	40 1/4	9	104	D6-35TUI-42SB	15 1/2	39 11/16	9 1/2	118	19 7/8	9 5/8
48	D5-35TUI-48SB	15 1/8	46 1/4	9	115	D6-35TUI-48SB	15 1/2	45 11/16	9 1/2	128	25 7/8	9 5/8
54	D5-35TUI-54SB	15 1/2	52 1/4	9 1/2	131	D6-35TUI-54SB	15 7/8	51 11/16	10	146	31 7/8	9 5/8
60	D5-35TUI-60SB	15 1/2	58 1/4	9 1/2	142	D6-35TUI-60SB	15 7/8	57 11/16	10	158	37 7/8	9 5/8
72	D5-35TUI-72SB	15 1/2	70 1/4	9 1/2	167	D6-35TUI-72SB	15 7/8	69 11/16	10	186	49 7/8	9 5/8

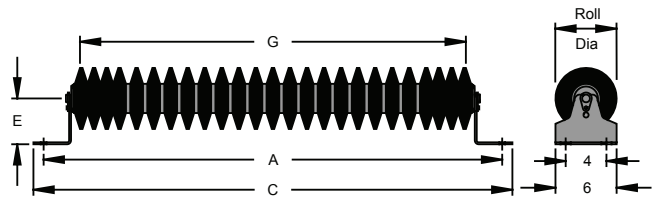

FLAT RUBBER DISC CARRIER

Belt Width	5" Roll Diameter				6" Roll Diameter				Standard Dimensions		
	E=4 1/2"		E=1 1/2"		E=4 1/2"		E=1 1/2"		A	C	G
	Part Number	WT	Part Number	WT	Part Number	WT	Part Number	WT			
24	D5-FRD-24SB	39	D5-FRD-24SB-1	38	D6-FRD-24SB	46	D6-FRD-24SB-1	45	33	35	25 7/8
30	D5-FRD-30SB	46	D5-FRD-30SB-1	45	D6-FRD-30SB	55	D6-FRD-30SB-1	54	39	41	31 7/8
36	D5-FRD-36SB	53	D5-FRD-36SB-1	52	D6-FRD-36SB	62	D6-FRD-36SB-1	61	45	47	37 7/8
42	D5-FRD-42SB	60	D5-FRD-42SB-1	59	D6-FRD-42SB	72	D6-FRD-42SB-1	71	51	53	43 7/8
48	D5-FRD-48SB	68	D5-FRD-48SB-1	67	D6-FRD-48SB	80	D6-FRD-48SB-1	79	57	59	49 7/8
54	D5-FRD-54SB	74	D5-FRD-54SB-1	73	D6-FRD-54SB	90	D6-FRD-54SB-1	89	63	65	55 7/8
60	D5-FRD-60SB	80	D5-FRD-60SB-1	79	D6-FRD-60SB	99	D6-FRD-60SB-1	98	69	71	61 7/8
72	D5-FRD-72SB	96	D5-FRD-72SB-1	95	D6-FRD-72SB	117	D6-FRD-72SB-1	116	81	83	73 7/8

CEMA D RETURN & V-RETURN

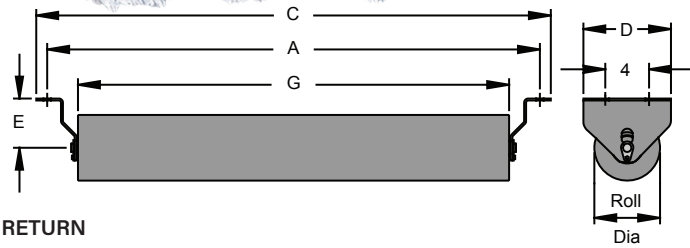

Belt Width	Standard Dimensions		
	A	C	G
24	33	35	27 3/8
30	39	41	33 3/8
36	45	57	39 3/8
42	51	53	45 3/8
48	57	59	51 3/8
54	63	65	57 3/8
60	69	71	63 3/8
72	81	83	75 3/8

RETURN

Belt Width	5" Roll Diameter					6" Roll Diameter				
	Std E=4 1/2"		Opt E=1 1/2"		WT	Std E=4 1/2"		Opt E=1 1/2"		WT
	Part Number	D	Part Number	D		Part Number	D	Part Number	D	
24	D5-R-24SB	9	D5-R-24SB-1	6	28	D6-R-24SB	9	D6-R-24SB-1	6	34
30	D5-R-30SB	9	D5-R-30SB-1	6	33	D6-R-30SB	9	D6-R-30SB-1	6	40
36	D5-R-36SB	9	D5-R-36SB-1	6	38	D6-R-36SB	9	D6-R-36SB-1	6	46
42	D5-R-42SB	9	D5-R-42SB-1	6	43	D6-R-42SB	9	D6-R-42SB-1	6	52
48	D5-R-48SB	9	D5-R-48SB-1	6	48	D6-R-48SB	9	D6-R-48SB-1	6	58
54	D5-R-54SB	9	D5-R-54SB-1	6	52	D6-R-54SB	9	D6-R-54SB-1	6	64
60	D5-R-60SB	9	D5-R-60SB-1	6	57	D6-R-60SB	9	D6-R-60SB-1	6	70
72	D5-R-72SB	9	D5-R-72SB-1	6	67	D6-R-72SB	9	D6-R-72SB-1	6	82

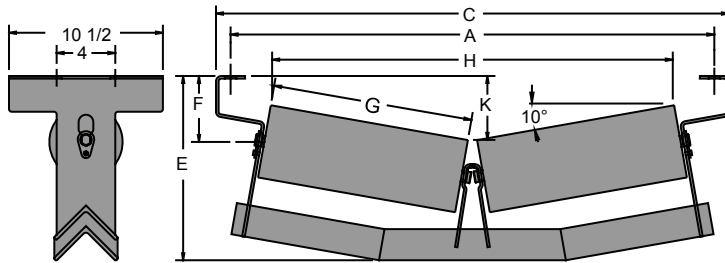

Belt Width	Standard Dimensions		
	A	C	G
24	33	35	13 5/8
30	39	41	16 11/16
36	45	47	19 3/4
42	51	53	22 13/16
48	57	59	25 7/8
54	63	65	28 7/8
60	69	71	31 15/16
66	75	77	35
72	81	83	38

V-RETURN IDLER (F = 4 1/2")

Belt Width	5" Roll Diameter					6" Roll Diameter				
	Part Number	E	H	K	WT	Part Number	E	H	K	WT
24	D5-10VR-24SB-4	12 9/16	27 5/8	4 1/2	54	D6-10VR-24SB-4	12 9/16	27 7/16	4	61
30	D5-10VR-30SB-4	13 1/16	33 5/8	5	61	D6-10VR-30SB-4	13 1/16	33 7/16	4 1/2	70
36	D5-10VR-36SB-4	13 5/8	39 5/8	5 9/16	68	D6-10VR-36SB-4	13 5/8	39 7/16	8 1/16	78
42	D5-10VR-42SB-4	14 1/8	45 5/8	6	75	D6-10VR-42SB-4	14 1/8	45 1/2	5 5/8	87
48	D5-10VR-48SB-4	14 11/16	51 7/16	6 1/8	83	D6-10VR-48SB-4	14 11/16	51 7/16	6 1/8	95
54	D5-10VR-54SB-4	15 5/8	57 5/8	7 1/8	90	D6-10VR-54SB-4	15 5/8	57 7/16	6 11/16	104
60	D5-10VR-60SB-4	16	63 5/8	7 11/16	106	D6-10VR-60SB-4	16	63 7/16	7 1/4	121
66	D5-10VR-66SB-4	16 1/2	69 5/8	8 1/4	114	D6-10VR-66SB-4	16 1/2	69 1/2	7 3/4	130
72	D5-10VR-72SB-4	17 3/16	75 9/16	8 3/4	121	D6-10VR-72SB-4	17 3/16	75 7/16	8 1/4	140

V-RETURN IDLER (F = 7")

Belt Width	5" Roll Diameter					6" Roll Diameter				
	Part Number	E	H	K	WT	Part Number	E	H	K	WT
24	D5-10VR-24SB-7	17 3/16	27 5/8	7	56	D6-10VR-24SB-7	17 3/16	27 7/16	6 1/2	64
30	D5-10VR-30SB-7	17 13/16	33 5/8	7 1/2	64	D6-10VR-30SB-7	17 13/16	33 7/16	16-Jul	72
36	D5-10VR-36SB-7	16 1/8	39 5/8	8 1/16	71	D6-10VR-36SB-7	16 1/8	39 7/16	7 9/16	81
42	D5-10VR-42SB-7	16 5/8	45 5/8	8 5/8	78	D6-10VR-42SB-7	16 5/8	45 1/2	8 1/8	89
48	D5-10VR-48SB-7	17 3/16	51 7/16	9 1/8	85	D6-10VR-48SB-7	17 3/16	51 7/16	8 5/8	98
54	D5-10VR-54SB-7	17 3/4	57 5/8	9 5/8	92	D6-10VR-54SB-7	17 3/4	57 7/16	9 3/16	106
60	D5-10VR-60SB-7	18 5/16	63 5/8	10 3/16	108	D6-10VR-60SB-7	18 5/16	63 7/16	9 3/4	124
66	D5-10VR-66SB-7	19	69 5/8	10 3/4	116	D6-10VR-66SB-7	19	69 1/2	10 1/4	133
72	D5-10VR-72SB-7	19 11/16	75 9/16	11 1/4	124	D6-10VR-72SB-7	19 11/16	75 7/16	10 3/4	142

CEMA D RETURN RUBBER DISC & V-RETURN RUBBER DISC

Belt Width	Standard Dimensions		
	A	C	G
24	33	35	26 7/8
30	39	41	32 7/8
36	45	57	38 7/8
42	51	53	44 7/8
48	57	59	50 7/8
54	63	65	56 7/8
60	69	71	62 7/8
72	81	83	74 7/8

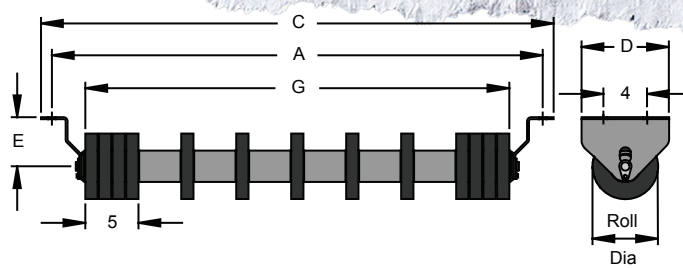

RETURN RUBBER DISC

Belt Width	5" Roll Diameter					6" Roll Diameter				
	Std E=4 1/2"		Opt E=1 1/2"		WT	Std E=4 1/2"		Opt E=1 1/2"		WT
	Part Number	D	Part Number	D		Part Number	D	Part Number	D	
24	D5-RRD-24SB	9	D5-RRD-24SB-1	6	31	D6-RRD-24SB	9	D6-RRD-24SB-1	6	36
30	D5-RRD-30SB	9	D5-RRD-30SB-1	6	36	D6-RRD-30SB	9	D6-RRD-30SB-1	6	41
36	D5-RRD-36SB	9	D5-RRD-36SB-1	6	40	D6-RRD-36SB	9	D6-RRD-36SB-1	6	46
42	D5-RRD-42SB	9	D5-RRD-42SB-1	6	45	D6-RRD-42SB	9	D6-RRD-42SB-1	6	51
48	D5-RRD-48SB	9	D5-RRD-48SB-1	6	49	D6-RRD-48SB	9	D6-RRD-48SB-1	6	56
54	D5-RRD-54SB	9	D5-RRD-54SB-1	6	54	D6-RRD-54SB	9	D6-RRD-54SB-1	6	61
60	D5-RRD-60SB	9	D5-RRD-60SB-1	6	58	D6-RRD-60SB	9	D6-RRD-60SB-1	6	66
72	D5-RRD-72SB	9	D5-RRD-72SB-1	6	67	D6-RRD-72SB	9	D6-RRD-72SB-1	6	75

Belt Width	Standard Dimensions		
	A	C	G
24	33	35	13 1/8
30	39	41	16 3/16
36	45	47	19 1/4
42	51	53	22 5/16
48	57	59	25 3/8
54	63	65	28 3/8
60	69	71	31 7/16
66	75	77	35
72	81	83	37 1/2

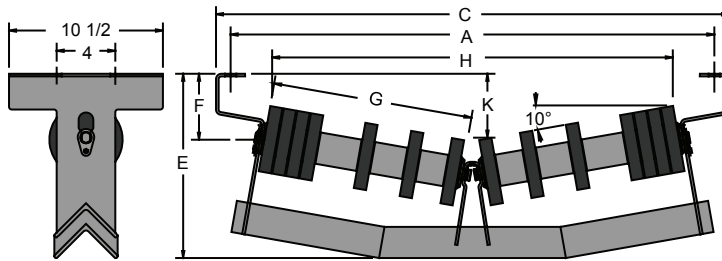

V-RETURN RUBBER DISC (STD F = 4 1/2")

Belt Width	5" Roll Diameter					6" Roll Dia				
	Part Number	E	H	K	WT	Part Number	E	H	K	WT
24	D5-10VRI-24SB-4	12 9/16	27 1/16	4 7/16	57	D6-10VRI-24SB-4	12 9/16	26 7/8	4 7/16	60
30	D5-10VRI-30SB-4	13 1/16	33 1/16	5	65	D6-10VRI-30SB-4	13 1/16	32 7/8	5	69
36	D5-10VRI-36SB-4	13 5/8	39 1/16	5 1/2	72	D6-10VRI-36SB-4	13 5/8	38 7/8	5 1/2	77
42	D5-10VRI-42SB-4	14 1/8	45 1/16	6	81	D6-10VRI-42SB-4	14 1/8	44 7/8	6	85
48	D5-10VRI-48SB-4	14 11/16	51 1/16	6 5/8	88	D6-10VRI-48SB-4	14 11/16	51 1/16	6 5/8	93
54	D5-10VRI-54SB-4	15 5/8	57 1/16	7 1/8	86	D6-10VRI-54SB-4	15 5/8	57 1/16	7 1/8	102
60	D5-10VRI-60SB-4	16	63 1/16	7 5/8	113	D6-10VRI-60SB-4	16	63 1/16	7 5/8	119
66	D5-10VRI-66SB-4	17 1/4	69 1/8	8 3/16	119	D6-10VRI-66SB-4	17 1/4	69 1/8	7 11/16	129
72	D5-10VRI-72SB-4	17 3/16	75 1/16	8 1/8	129	D6-10VRI-72SB-4	17 3/16	69 1/16	8 1/8	136

V-RETURN RUBBER DISC (F = 7")

Belt Width	5" Roll Diameter					6" Roll Diameter				
	Part Number	E	H	K	WT	Part Number	E	H	K	WT
24	D5-10VRI-24SB-7	17 3/16	27 1/16	6 15/16	59	D6-10VRI-24SB-7	17 3/16	26 7/8	6 15/16	63
30	D5-10VRI-30SB-7	17 13/16	33 1/16	7 1/2	67	D6-10VRI-30SB-7	17 13/16	32 7/8	7 1/2	72
36	D5-10VRI-36SB-7	16 1/8	39 1/16	8	75	D6-10VRI-36SB-7	16 1/8	38 7/8	8	79
42	D5-10VRI-42SB-7	16 5/8	45 1/16	8 9/16	83	D6-10VRI-42SB-7	16 5/8	44 7/8	8 9/16	88
48	D5-10VRI-48SB-7	17 3/16	51 1/16	9	90	D6-10VRI-48SB-7	17 3/16	51 1/16	9	95
54	D5-10VRI-54SB-7	17 3/4	57 1/16	9 5/8	99	D6-10VRI-54SB-7	17 3/4	57 1/16	9 5/8	104
60	D5-10VRI-60SB-7	18 5/16	63 1/16	10 1/8	116	D6-10VRI-60SB-7	18 5/16	63 1/16	10 1/8	122
66	D5-10VRI-66SB-7	19 11/16	69 1/8	10 11/16	122	D6-10VRI-66SB-7	19 11/16	69 1/8	10 3/16	132
72	D5-10VRI-72SB-7	20 1/4	75 1/16	11 3/16	132	D6-10VRI-72SB-7	20 1/4	69 1/16	11 3/16	139

CEMA D LSI & INVERTED V-RETURN

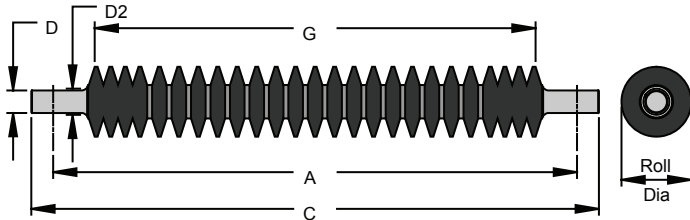

Live Shaft Idlers are available in several different configurations with different bearing journal diameters or in steel.

Please contact PPI with your requirements.

LIVE SHAFT IMPACT FLAT CARRIER

Belt Width	5" Roll Diameter		6" Roll Diameter		Standard Dimensions				
	Part Number	WT	Part Number	WT	A	C	D	D2	G
18	D5-35LSI-18	62	D6-35LSI-18	68	27	31 1/4	2 3/16	2 7/8	19 7/8
24	D5-35LSI-24	77	D6-35LSI-24	84	33	37 1/4	2 3/16	2 7/8	25 7/8
30	D5-35LSI-30	92	D6-35LSI-30	100	39	43 1/4	2 3/16	2 7/8	31 7/8
36	D5-35LSI-36	106	D6-35LSI-36	116	45	49 1/4	2 3/16	2 7/8	37 7/8
42	D5-35LSI-42	121	D6-35LSI-42	132	51	55 1/4	2 3/16	2 7/8	43 7/8
48	D5-35LSI-48	135	D6-35LSI-48	148	57	61 1/4	2 3/16	2 7/8	49 7/8
54	D5-35LSI-54	150	D6-35LSI-54	165	63	67 1/4	2 3/16	2 7/8	55 7/8
60	D5-35LSI-60	164	D6-35LSI-60	181	69	73 1/4	2 3/16	2 7/8	61 7/8
72	D5-35LSI-72	193	D6-35LSI-72	213	81	85 1/4	2 3/16	2 7/8	73 7/8

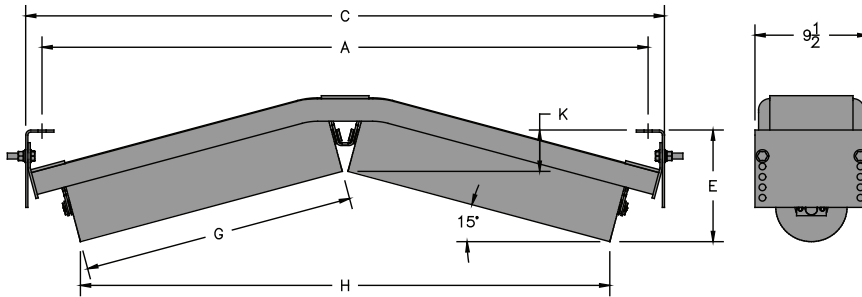

Belt Width	Standard Dimensions		
	A	C	G
24	33	35.75	13.66
30	39	41.75	16.70
36	45	47.75	19.75
42	51	53.75	22.81
48	57	59.75	25.84
54	63	65.75	28.88
60	69	71.75	31.94
66	75	76.75	35.00
72	81	82.75	38.00
78	87	88.75	41.05

INVERTED V-RETURN

Belt Width	5" Roll Diameter					6" Roll Diameter				
	Part Number	E	H	K	WT	Part Number	E	H	K	WT
24	D5-15IVR-24SB-4	8.94	27.12	5.41	81	D6-15IVR-24SB-4	9.42	26.86	5.89	88
30	D5-15IVR-30SB-4	8.93	33.00	4.60	90	D6-15IVR-30SB-4	9.41	32.74	5.08	99
36	D5-15IVR-36SB-4	8.91	38.89	3.80	100	D6-15IVR-36SB-4	9.39	38.63	4.28	110
42	D5-15IVR-42SB-4	8.90	44.80	3.00	110	D6-15IVR-42SB-4	9.38	44.55	3.48	121
48	D5-15IVR-48SB-4	8.88	50.66	2.19	120	D6-15IVR-48SB-4	9.36	50.40	2.67	133
54	D5-15IVR-54SB-4	8.86	56.52	1.39	130	D6-15IVR-54SB-4	9.34	56.26	1.87	144
60	D5-15IVR-60SB-4	8.85	62.43	0.58	139	D6-15IVR-60SB-4	9.33	62.18	1.06	155
66	D5-15IVR-66SB-4	8.84	68.35	-0.22	149	D6-15IVR-66SB-4	9.32	68.09	0.26	166
72	D5-15IVR-72SB-4	8.81	74.14	-1.02	159	D6-15IVR-72SB-4	9.29	73.89	-0.54	177
78	D5-15IVR-78SB-4	8.80	80.04	-1.83	169	D6-15IVR-78SB-4	9.28	79.78	-1.34	188

*Dimensions are for top position. There are four additional positions available.

CEMA D LSI & INVERTED V-RETURN RUBBER DISC

Live Shaft Idlers are available in several different configurations, with different bearing journal diameters or in steel.

Please contact PPI with your requirements.

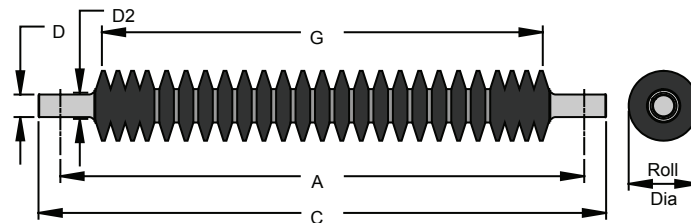

LIVE SHAFT IMPACT FLAT CARRIER

Belt Width	5" Roll Diameter		6" Roll Diameter		Standard Dimensions				
	Part Number	WT	Part Number	WT	A	C	D	D2	G
18	D5-39LSI-18	65	D6-39LSI-18	70	27	31 1/4	2 7/16	2 7/8	19 7/8
24	D5-39LSI-24	79	D6-39LSI-24	86	33	37 1/4	2 7/16	2 7/8	25 7/8
30	D5-39LSI-30	94	D6-39LSI-30	103	39	43 1/4	2 7/16	2 7/8	31 7/8
36	D5-39LSI-36	109	D6-39LSI-36	116	45	49 1/4	2 7/16	2 7/8	37 7/8
42	D5-39LSI-42	123	D6-39LSI-42	135	51	55 1/4	2 7/16	2 7/8	43 7/8
48	D5-39LSI-48	138	D6-39LSI-48	151	57	61 1/4	2 7/16	2 7/8	49 7/8
54	D5-39LSI-54	152	D6-39LSI-54	167	63	67 1/4	2 7/16	2 7/8	55 7/8
60	D5-39LSI-60	167	D6-39LSI-60	184	69	73 1/4	2 7/16	2 7/8	61 7/8
72	D5-39LSI-72	196	D6-39LSI-72	215	81	85 1/4	2 7/16	2 7/8	73 7/8

Belt Width	Standard Dimensions		
	A	C	G
24	33	35.75	13.16
30	39	41.75	16.20
36	45	47.75	19.25
42	51	53.75	22.31
48	57	59.75	25.34
54	63	65.75	28.38
60	69	71.75	31.44
66	75	76.75	34.50
72	81	82.75	37.50
78	87	88.75	40.55

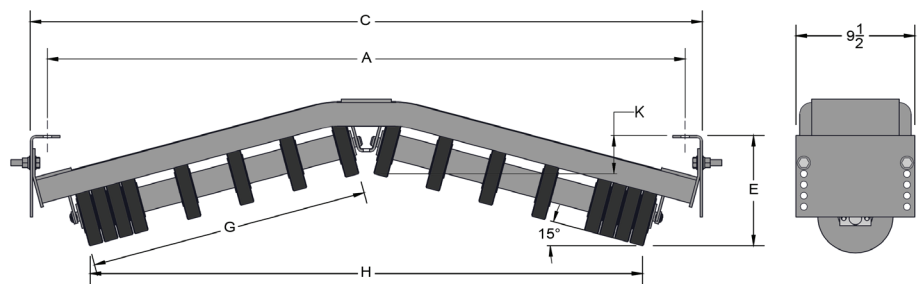

INVERTED V-RETURN RUBBER DISC

Belt Width	5" Roll Diameter					6" Roll Diameter				
	Part Number	E	H	K	WT	Part Number	E	H	K	WT
24	D515IVRI24SB-4	8.87	26.44	5.50	78	D615IVRI24SB-4	9.35	26.19	5.98	83
30	D515IVRI30SB-4	8.85	32.33	4.69	88	D615IVRI30SB-4	9.34	32.07	5.17	93
36	D515IVRI36SB-4	8.84	38.22	3.89	96	D615IVRI36SB-4	9.32	37.96	4.37	101.58
42	D515IVRI42SB-4	8.83	44.13	3.08	106	D615IVRI42SB-4	9.31	43.87	3.57	112.06
48	D515IVRI48SB-4	8.81	49.99	2.28	114	D615IVRI48SB-4	9.29	49.73	2.76	120.24
54	D515IVRI54SB-4	8.79	55.85	1.48	124	D615IVRI54SB-4	9.27	55.59	1.96	130.67
60	D515IVRI60SB-4	8.78	61.76	0.67	133	D615IVRI60SB-4	9.26	61.50	1.16	139.19
66	D515IVRI66SB-4	8.76	67.68	-0.14	142	D615IVRI66SB-4	9.24	67.42	0.34	149.41
72	D515IVRI72SB-4	8.73	73.47	-0.94	151	D615IVRI72SB-4	9.21	73.21	-0.46	160
78	D515IVRI78SB-4	8.72	79.48	-1.75	161	D615IVRI78SB-4	9.20	79.22	-1.26	170

*Dimensions are for top position. There are four additional positions available.

CEMA D SELF-ALIGNER – TROUGHING IDLERS

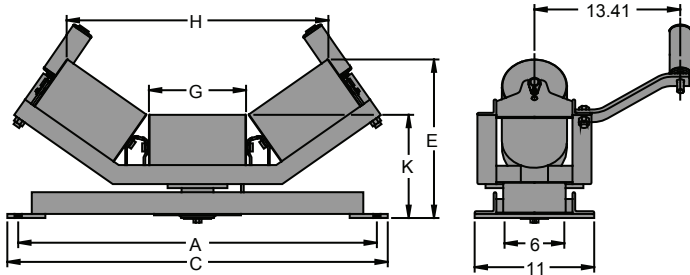

Belt Width	Standard Dimensions			Wide Base	
	A	C	G	Aw	Cw
24	33	35	8 15/16	39	41
30	39	41	11 1/8	45	47
36	45	47	13 1/4	51	53
42	51	53	15 7/16	57	59
48	57	59	17 5/8	63	65
54	63	65	19 3/4	69	71
60	69	71	21 3/4	75	77
72	81	83	26	87	89

20° SELF-ALIGNER EQUAL TROUGHING IDLER

Belt Width	5" Roll Diameter					6" Roll Diameter				
	Part Number	E	H	K	WT	Part Number	E	H	K	WT
24	D5-20TESA-24SB	12 3/16	27 1/16	9	112	D6-20TESA-24SB	12 5/8	26 11/16	9 1/2	120
30	D5-20TESA-30SB	12 15/16	33 3/8	9	123	D6-20TESA-30SB	13 3/8	32 15/16	9 1/2	133
36	D5-20TESA-36SB	13 11/16	39 7/16	9	135	D6-20TESA-36SB	14 1/8	39 1/8	9 1/2	146
42	D5-20TESA-42SB	14 15/16	45 3/4	9 1/2	164	D6-20TESA-42SB	15 3/8	45 7/16	10	177
48	D5-20TESA-48SB	15 11/16	52 1/16	9 1/2	178	D6-20TESA-48SB	16 1/8	51 3/4	10	192
54	D5-20TESA-54SB	16 3/8	58 3/16	10	221	D6-20TESA-54SB	16 7/8	57 13/16	10 1/2	236
60	D5-20TESA-60SB	17 1/16	63 7/8	10	236	D6-20TESA-60SB	17 1/2	63 9/16	10 1/2	253
72	D5-20TESA-72SB	18 3/8	76 3/16	10	265	D6-20TESA-72SB	18 7/8	75 13/16	10 1/2	284

35° SELF-ALIGNER EQUAL TROUGHING IDLER

Belt Width	5" Roll Diameter					6" Roll Diameter				
	Part Number	E	H	K	WT	Part Number	E	H	K	WT
24	D5-35TESA-24SB	14 5/16	24 9/16	9	115	D6-35TESA-24SB	14 3/4	24 1/16	9 1/2	124
30	D5-35TESA-30SB	15 9/16	30 3/8	9	127	D6-35TESA-30SB	16 1/16	29 13/16	9 1/2	137
36	D5-35TESA-36SB	16 3/4	35 15/16	9	139	D6-35TESA-36SB	17 3/16	35 7/16	9 1/2	150
42	D5-35TESA-42SB	18 9/16	41 3/4	9 1/2	168	D6-35TESA-42SB	18 15/16	41 3/16	10	181
48	D5-35TESA-48SB	19 13/16	47 1/2	9 1/2	182	D6-35TESA-48SB	20 3/16	46 15/16	10	196
54	D5-35TESA-54SB	21	53 1/8	10	225	D6-35TESA-54SB	21 7/16	52 9/16	10 1/2	241
60	D5-35TESA-60SB	22 3/16	58 3/8	10	241	D6-35TESA-60SB	22 9/16	57 7/8	10 1/2	258
72	D5-35TESA-72SB	24 7/16	69 9/16	10	273	D6-35TESA-72SB	24 7/8	69 1/16	10 1/2	293

45° SELF-ALIGNER EQUAL TROUGHING IDLER

Belt Width	5" Roll Diameter					6" Roll Diameter				
	Part Number	E	H	K	WT	Part Number	E	H	K	WT
24	D5-45TESA-24SB	15 3/8	22 3/4	9	116	D6-45TESA-24SB	15 7/8	22 1/8	9 1/2	124
30	D5-45TESA-30SB	16 15/16	28 1/16	9	128	D6-45TESA-30SB	17 1/2	27 3/8	9 1/2	137
36	D5-45TESA-36SB	18 7/16	33 1/8	9	139	D6-45TESA-36SB	18 15/16	32 5/16	9 1/2	150
42	D5-45TESA-42SB	20 7/16	38 7/16	9 1/2	169	D6-45TESA-42SB	21	37 11/16	10	182
48	D5-45TESA-48SB	22	43 11/16	9 1/2	183	D6-45TESA-48SB	22 9/16	43 1/16	10	197
54	D5-45TESA-54SB	23 11/16	48 13/16	10	227	D6-45TESA-54SB	24 1/16	48 1/16	10 1/2	242
60	D5-45TESA-60SB	25 1/8	53 11/16	10	242	D6-45TESA-60SB	25 7/16	53	10 1/2	259
72	D5-45TESA-72SB	28	63 15/16	10	275	D6-45TESA-72SB	28 5/16	63 1/4	10 1/2	294

CEMA D SELF-ALIGNER RETURN & FLAT

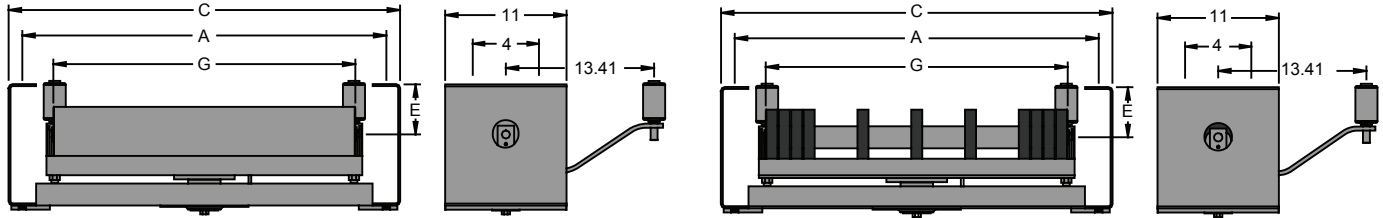

RETURN SELF-ALIGNER

Belt Width	5" Roll Diameter				6" Roll Diameter				Standard Dimensions				Wide Base	
	E=4½"	WT	E=1½"	WT	E=4½"	WT	E=1½"	WT	A	C	E	G	Aw	Cw
24	D5-RSA-24SB	114	D5-RSA-24SB-1	111	D6-RSA-24SB	121	D6-RSA-24SB-1	117	33	35	4 1/2	27 3/8	39	41
30	D5-RSA-30SB	125	D5-RSA-30SB-1	122	D6-RSA-30SB	133	D6-RSA-30SB-1	130	39	41	4 1/2	33 3/8	45	47
36	D5-RSA-36SB	136	D5-RSA-36SB-1	133	D6-RSA-36SB	146	D6-RSA-36SB-1	142	45	47	4 1/2	39 3/8	51	53
42	D5-RSA-42SB	163	D5-RSA-42SB-1	160	D6-RSA-42SB	174	D6-RSA-42SB-1	170	51	53	4 1/2	45 3/8	57	59
48	D5-RSA-48SB	176	D5-RSA-48SB-1	173	D6-RSA-48SB	188	D6-RSA-48SB-1	185	57	59	4 1/2	51 3/8	63	65
54	D5-RSA-54SB	189	D5-RSA-54SB-1	186	D6-RSA-54SB	203	D6-RSA-54SB-1	199	63	65	4 1/2	57 3/8	69	71
60	D5-RSA-60SB	202	D5-RSA-60SB-1	199	D6-RSA-60SB	217	D6-RSA-60SB-1	214	69	71	4 1/2	63 3/8	75	77
72	D5-RSA-72SB	247	D5-RSA-72SB-1	244	D6-RSA-72SB	264	D6-RSA-72SB-1	261	81	83	4 1/2	75 3/8	87	89

RETURN RUBBER DISC SELF-ALIGNER

Belt Width	5" Roll Diameter				6" Roll Diameter				Standard Dimensions				Wide Base	
	E=4½"	WT	E=1½"	WT	E=4½"	WT	E=1½"	WT	A	C	E	G	Aw	Cw
24	D5-RRDSA-24SB	121	D5-RRDSA-24SB-1	118	D6-RRDSA-24SB	126	D6-RRDSA-24SB-1	122	33	35	4 1/2	26 7/8	39	41
30	D5-RRDSA-30SB	133	D5-RRDSA-30SB-1	130	D6-RRDSA-30SB	138	D6-RRDSA-30SB-1	135	39	41	4 1/2	32 7/8	45	47
36	D5-RRDSA-36SB	146	D5-RRDSA-36SB-1	142	D6-RRDSA-36SB	151	D6-RRDSA-36SB-1	147	45	47	4 1/2	38 7/8	51	53
42	D5-RRDSA-42SB	173	D5-RRDSA-42SB-1	170	D6-RRDSA-42SB	179	D6-RRDSA-42SB-1	175	51	53	4 1/2	44 7/8	57	59
48	D5-RRDSA-48SB	187	D5-RRDSA-48SB-1	184	D6-RRDSA-48SB	193	D6-RRDSA-48SB-1	190	57	59	4 1/2	50 7/8	63	65
54	D5-RRDSA-54SB	201	D5-RRDSA-54SB-1	198	D6-RRDSA-54SB	208	D6-RRDSA-54SB-1	204	63	65	4 1/2	56 7/8	69	71
60	D5-RRDSA-60SB	215	D5-RRDSA-60SB-1	212	D6-RRDSA-60SB	222	D6-RRDSA-60SB-1	219	69	71	4 1/2	62 7/8	75	77
72	D5-RRDSA-72SB	262	D5-RRDSA-72SB-1	259	D6-RRDSA-72SB	269	D6-RRDSA-72SB-1	266	81	83	4 1/2	74 7/8	87	89

RSA's and RRDSA's are available with 1 1/2" drop, add "-1" to the end of the part number.

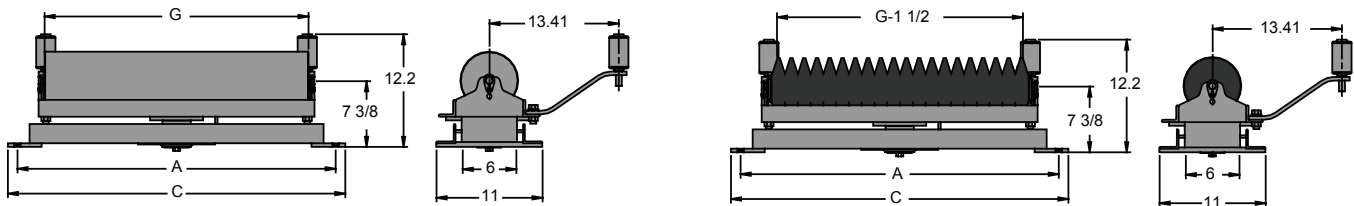

FLAT CARRIER SELF-ALIGNER

Belt Width	Steel Rolls				Rubber Disc Rolls				Standard Dimensions				Wide Base	
	5" Roll Diameter		6" Roll Diameter		5" Roll Diameter		6" Roll Diameter		A	C	G	Aw	Cw	
	Part Number	WT	Part Number	WT	Part Number	WT	Part Number	WT						
24	D5-FSA-24SB	98	D6-FSA-24SB	105	D5-FRDSA-24SB	107	D6-FRDSA-24SB	113	33	35	27 3/8	39	41	
30	D5-FSA-30SB	109	D6-FSA-30SB	117	D5-FRDSA-30SB	121	D6-FRDSA-30SB	127	39	41	33 3/8	45	47	
36	D5-FSA-36SB	120	D6-FSA-36SB	130	D5-FRDSA-36SB	134	D6-FRDSA-36SB	142	45	47	39 3/8	51	53	
42	D5-FSA-42SB	147	D6-FSA-42SB	158	D5-FRDSA-42SB	163	D6-FRDSA-42SB	172	51	53	45 3/8	57	59	
48	D5-FSA-48SB	160	D6-FSA-48SB	172	D5-FRDSA-48SB	178	D6-FRDSA-48SB	188	57	59	51 3/8	63	65	
54	D5-FSA-54SB	187	D6-FSA-54SB	201	D5-FRDSA-54SB	205	D6-FRDSA-54SB	219	63	65	57 3/8	69	71	
60	D5-FSA-60SB	202	D6-FSA-60SB	216	D5-FRDSA-60SB	224	D6-FRDSA-60SB	237	69	71	63 3/8	75	77	
72	D5-FSA-72SB	231	D6-FSA-72SB	248	D5-FRDSA-72SB	258	D6-FRDSA-72SB	273	81	83	75 3/8	87	89	

CEMA E CLASS IDLERS PRODUCT OFFERINGS

- Equal Troughing Idler
- Equal Impact Troughing Idler
- Unequal Troughing Idler
- Unequal Impact Troughing Idler
- Flat Carrier
- Impact Flat Carrier
- Return Roller
- Return Rubber Disc
- Channel Inset Flat Carrier
- Channel Inset Flat Rubber Disc Carrier
- Channel Inset Troughing Idler
- Channel Inset Return Roller
- Channel Inset Impact Troughing Idler
- Channel Inset Impact Return Roller
- Self-Aligner Troughing Idler
- Self-Aligner Return Roller
- Self-Aligner Flat Roller
- Additional Configurations Available

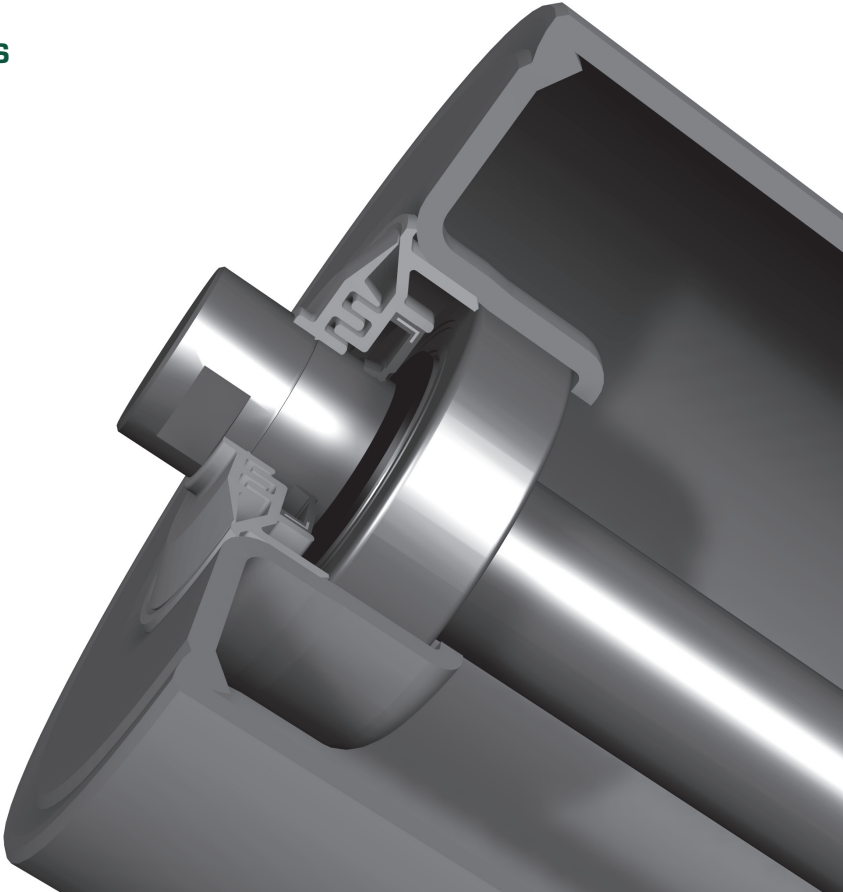

CEMA E LOAD RATINGS

BELT WIDTH	TROUGHING ANGLE			RETURN & FLAT	TWO-ROLL V-RETURNS	UNEQUAL (Picking)	LIVE SHAFT
	20°	35°	45°				
36	1,800	1,800	1,800	1,000	1,300	1,260	2,100
42	1,800	1,800	1,800	1,000	1,300	1,200	2,100
48	1,800	1,800	1,800	1,000	1,300	1,000	2,100
54	1,800	1,800	1,800	925	1,300	1,000	2,100
60	1,800	1,800	1,800	850	1,300	1,000	2,100
66	1,800	1,800	1,800	775	1,300	1,000	2,100
72	1,800	1,800	1,800	700	1,300	925	2,100
78	-	-	-	625	1,300	-	2,100
84	1,800	1,674	1,620	550	1,300	775	1,825
90	-	-	-	475	1,300	-	-
96	1,750	1,628	1,575	400	1,300	625	-
102	-	-	-	250	1,300	-	-

CEMA E EQUAL TROUGHING IDLERS

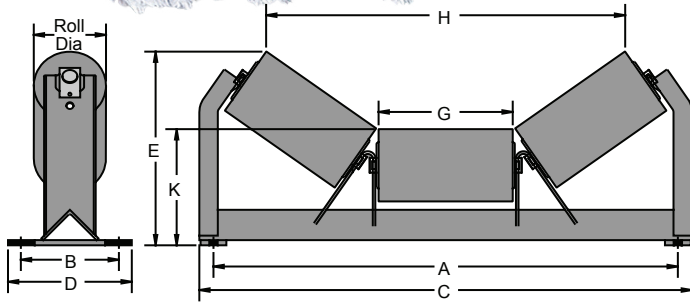

Belt Width	Standard Dimensions					Wide Base	
	A	B	C	D	G	Aw	Cw
36	45	7 1/2	49	12	13	51	53 1/2
42	51	7 1/2	54 3/4	12	15	57	59 1/2
48	57	7 1/2	62 5/8	12	17 3/4	63	65 1/2
54	63	7 1/2	68 3/8	12	19 3/4	69	71 1/2
60	69	7 1/2	74 1/4	12	21 3/4	75	77 1/2
66	75	8 1/2	79 7/8	12	23 3/4	81	83 1/2
72	81	8 1/2	85 7/8	12	25 3/4	87	89 1/2
78	87	8 1/2	91 3/8	12	27 3/4	93	95 1/2
84	93	9	97 1/4	14 1/2	29 3/4	99	101 1/2
90	99	9	102 7/8	14 1/2	31 3/4	102	107 1/2
96	105	9	108 3/4	14 1/2	33 3/4	111	113 1/2

20° EQUAL TROUGHING IDLER

Belt Width	6" Roll Diameter					7" Roll Diameter				
	Part Number	E	H	K	WT	Part Number	E	H	K	WT
36	E6-20TE-36SB	15 3/8	39 3/4	10 3/4	125	E7-20TE-36SB	15 7/8	39 3/8	11 1/4	134
42	E6-20TE-42SB	16 1/16	45 1/2	10 3/4	138	E7-20TE-42SB	16 9/16	45 1/8	11 1/4	147
48	E6-20TE-48SB	17	53 7/16	10 3/4	154	E7-20TE-48SB	17 1/2	53 1/16	11 1/4	165
54	E6-20TE-54SB	17 11/16	59 3/16	10 3/4	174	E7-20TE-54SB	18 3/16	58 7/8	11 1/4	186
60	E6-20TE-60SB	18 3/8	64 15/16	10 3/4	187	E7-20TE-60SB	18 7/8	64 9/16	11 1/4	200
66	E6-20TE-66SB	19 13/16	70 11/16	11 1/2	213	E7-20TE-66SB	20 1/4	70 5/16	12	227
72	E6-20TE-72SB	20 1/2	76 7/16	11 1/2	227	E7-20TE-72SB	20 15/16	76 1/8	12	241
78	E6-20TE-78SB	21 1/4	82 3/16	11 1/2	240	E7-20TE-78SB	21 11/16	81 15/16	12	255
84	E6-20TE-84SB	21 15/16	87 15/16	11 5/8	303	E7-20TE-84SB	22 7/16	87 9/16	12 1/8	319
90	E6-20TE-90SB	22 5/8	93 3/4	11 5/8	319	E7-20TE-90SB	23 1/8	93 3/8	12 1/8	336
96	E6-20TE-96SB	23 5/16	99 1/2	11 5/8	336	E7-20TE-96SB	23 13/16	99 1/8	12 1/8	353

35° EQUAL TROUGHING IDLER

Belt Width	6" Roll Diameter					7" Roll Diameter				
	Part Number	E	H	K	WT	Part Number	E	H	K	WT
36	E6-35TE-36SB	18 5/16	35 3/8	10 3/4	129	E7-35TE-36SB	18 3/4	34 3/4	11 1/4	138
42	E6-35TE-42SB	19 1/2	40 5/8	10 3/4	141	E7-35TE-42SB	19 7/8	40 1/16	11 1/4	151
48	E6-35TE-48SB	21 1/16	47 7/8	10 3/4	157	E7-35TE-48SB	21 1/2	47 5/16	11 1/4	168
54	E6-35TE-54SB	22 1/4	53 3/16	10 3/4	178	E7-35TE-54SB	22 5/8	52 5/8	11 1/4	190
60	E6-35TE-60SB	23 3/8	58 7/16	10 3/4	191	E7-35TE-60SB	23 3/4	57 7/8	11 1/4	203
66	E6-35TE-66SB	25 1/4	63 3/4	11 1/2	217	E7-35TE-66SB	25 11/16	63 1/8	12	231
72	E6-35TE-72SB	26 7/16	69	11 1/2	231	E7-35TE-72SB	26 13/16	68 7/16	12	246
78	E6-35TE-78SB	27 3/4	74 1/4	11 1/2	245	E7-35TE-78SB	28	73 11/16	12	261
84	E6-35TE-84SB	28 13/16	79 9/16	11 5/8	308	E7-35TE-84SB	29 3/16	78 15/16	12 1/8	324
90	E6-35TE-90SB	30	84 7/8	11 5/8	325	E7-35TE-90SB	30 3/8	84 1/4	12 1/8	342
96	E6-35TE-96SB	31 1/8	90 1/8	11 5/8	342	E7-35TE-96SB	31 1/2	89 1/2	12 1/8	360

45° EQUAL TROUGHING IDLER

Belt Width	6" Roll Diameter					7" Roll Diameter				
	Part Number	E	H	K	WT	Part Number	E	H	K	WT
36	E6-45TE-36SB	20 1/8	32 9/16	10 3/4	132	E7-45TE-36SB	20 1/2	31 7/8	11 1/4	141
42	E6-45TE-42SB	21 9/16	37 3/8	10 3/4	144	E7-45TE-42SB	21 7/8	36 11/16	11 1/4	154
48	E6-45TE-48SB	23 1/2	44 1/16	10 3/4	160	E7-45TE-48SB	23 7/8	43 5/16	11 1/4	171
54	E6-45TE-54SB	24 15/16	48 7/8	10 3/4	181	E7-45TE-54SB	25 1/4	48 1/8	11 1/4	193
60	E6-45TE-60SB	26 5/16	53 11/16	10 3/4	194	E7-45TE-60SB	26 11/16	52 15/16	11 1/4	207
66	E6-45TE-66SB	28 1/2	58 9/16	11 1/2	221	E7-45TE-66SB	28 13/16	57 13/16	12	235
72	E6-45TE-72SB	29 7/8	63 3/8	11 1/2	235	E7-45TE-72SB	30 1/4	62 5/8	12	250
78	E6-45TE-78SB	31 3/8	68 3/16	11 1/2	250	E7-45TE-78SB	31 3/4	67 1/2	12	265
84	E6-45TE-84SB	32 13/16	73	11 5/8	313	E7-45TE-84SB	33 3/16	72 5/16	12 1/8	329
90	E6-45TE-90SB	34 1/4	77 13/16	11 5/8	330	E7-45TE-90SB	34 5/8	77 1/8	12 1/8	347
96	E6-45TE-96SB	35 11/16	82 5/8	11 5/8	347	E7-45TE-96SB	36	81 15/16	12 1/8	365

CEMA E EQUAL IMPACT TROUGHING IDLERS

Belt Width	Standard Dimensions					Wide Base	
	A	B	C	D	G	Aw	Cw
36	45	9 1/2	49	12	13	51	53 1/2
42	51	9 1/2	54 3/4	12	15	57	59 1/2
48	57	9 1/2	62 5/8	12	17 3/4	63	65 1/2
54	63	9 1/2	68 3/8	12	19 3/4	69	71 1/2
60	69	9 1/2	74 1/4	12	21 3/4	75	77 1/2
66	75	9 1/2	79 7/8	12	23 3/4	81	83 1/2
72	81	9 1/2	85 7/8	12	25 3/4	87	89 1/2
78	87	9 1/2	91 3/8	12	27 3/4	93	95 1/2
84	93	12	97 1/4	14 1/2	29 3/4	99	101 1/2
90	99	12	102 7/8	14 1/2	31 3/4	102	107 1/2
96	105	12	108 3/4	14 1/2	33 3/4	111	113 1/2

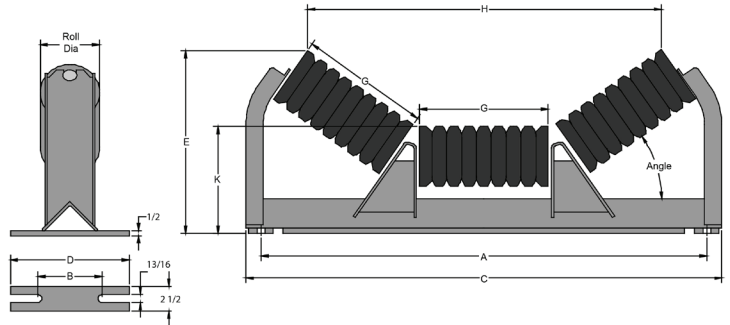

20° EQUAL IMPACT TROUGHING IDLER

Belt Width	6" Roll Diameter					7" Roll Diameter				
	Part Number	E	H	K	WT	Part Number	E	H	K	WT
36	E6-20TEI-36SB	15 3/8	39 3/4	10 3/4	192	E7-20TEI-36SB	15 7/8	39 3/8	11 1/4	195
42	E6-20TEI-42SB	16 1/16	45 1/2	10 3/4	215	E7-20TEI-42SB	16 9/16	45 1/8	11 1/4	218
48	E6-20TEI-48SB	17	53 7/16	10 3/4	245	E7-20TEI-48SB	17 1/2	53 1/16	11 1/4	249
54	E6-20TEI-54SB	17 11/16	59 3/16	10 3/4	288	E7-20TEI-54SB	18 3/16	58 7/8	11 1/4	292
60	E6-20TEI-60SB	18 3/8	64 15/16	10 3/4	304	E7-20TEI-60SB	18 7/8	64 9/16	11 1/4	278
66	E6-20TEI-66SB	19 13/16	70 11/16	11 1/2	358	E7-20TEI-66SB	20 1/4	70 5/16	12	363
72	E6-20TEI-72SB	20 1/2	76 7/16	11 1/2	383	E7-20TEI-72SB	20 15/16	76 1/8	12	389
78	E6-20TEI-78SB	21 1/4	82 3/16	11 1/2	412	E7-20TEI-78SB	21 11/16	81 15/16	12	418
84	E6-20TEI-84SB	21 15/16	87 15/16	11 5/8	487	E7-20TEI-84SB	22 7/16	87 9/16	12 1/8	493
90	E6-20TEI-90SB	22 5/8	93 3/4	11 5/8	515	E7-20TEI-90SB	23 1/8	93 3/8	12 1/8	522
96	E6-20TEI-96SB	23 5/16	99 1/2	11 5/8	546	E7-20TEI-96SB	23 13/16	99 1/8	12 1/8	554

35° EQUAL IMPACT TROUGHING IDLER

Belt Width	6" Roll Diameter					7" Roll Diameter				
	Part Number	E	H	K	WT	Part Number	E	H	K	WT
36	E6-35TEI-36SB	18 5/16	35 3/8	10 3/4	198	E7-35TEI-36SB	18 3/4	34 3/4	11 1/4	201
42	E6-35TEI-42SB	19 1/2	40 5/8	10 3/4	220	E7-35TEI-42SB	19 7/8	40 1/16	11 1/4	223
48	E6-35TEI-48SB	21 1/16	47 7/8	10 3/4	250	E7-35TEI-48SB	21 1/2	47 5/16	11 1/4	254
54	E6-35TEI-54SB	22 1/4	53 3/16	10 3/4	281	E7-35TEI-54SB	22 5/8	52 5/8	11 1/4	285
60	E6-35TEI-60SB	23 3/8	58 7/16	10 3/4	309	E7-35TEI-60SB	23 3/4	57 7/8	11 1/4	283
66	E6-35TEI-66SB	25 1/4	63 3/4	11 1/2	363	E7-35TEI-66SB	25 11/16	63 1/8	12	369
72	E6-35TEI-72SB	26 7/16	69	11 1/2	389	E7-35TEI-72SB	26 13/16	68 7/16	12	395
78	E6-35TEI-78SB	27 3/4	74 1/4	11 1/2	418	E7-35TEI-78SB	28	73 11/16	12	425
84	E6-35TEI-84SB	28 13/16	79 9/16	11 5/8	493	E7-35TEI-84SB	29 3/16	78 15/16	12 1/8	500
90	E6-35TEI-90SB	30	84 7/8	11 5/8	522	E7-35TEI-90SB	30 3/8	84 1/4	12 1/8	529
96	E6-35TEI-96SB	31 1/8	90 1/8	11 5/8	554	E7-35TEI-96SB	31 1/2	89 1/2	12 1/8	562

45° EQUAL IMPACT TROUGHING IDLER

Belt Width	6" Roll Diameter					7" Roll Diameter				
	Part Number	E	H	K	WT	Part Number	E	H	K	WT
36	E6-45TEI-36SB	20 1/8	32 9/16	10 3/4	203	E7-45TEI-36SB	20 1/2	31 7/8	11 1/4	206
42	E6-45TEI-42SB	21 9/16	37 3/8	10 3/4	225	E7-45TEI-42SB	21 7/8	36 11/16	11 1/4	228
48	E6-45TEI-48SB	23 1/2	44 1/16	10 3/4	255	E7-45TEI-48SB	23 7/8	43 5/16	11 1/4	259
54	E6-45TEI-54SB	24 15/16	48 7/8	10 3/4	286	E7-45TEI-54SB	25 1/4	48 1/8	11 1/4	291
60	E6-45TEI-60SB	26 5/16	53 11/16	10 3/4	314	E7-45TEI-60SB	26 11/16	52 15/16	11 1/4	288
66	E6-45TEI-66SB	28 1/2	58 9/16	11 1/2	370	E7-45TEI-66SB	28 13/16	57 13/16	12	375
72	E6-45TEI-72SB	29 7/8	63 3/8	11 1/2	396	E7-45TEI-72SB	30 1/4	62 5/8	12	401
78	E6-45TEI-78SB	31 3/8	68 3/16	11 1/2	425	E7-45TEI-78SB	31 3/4	67 1/2	12	431
84	E6-45TEI-84SB	32 13/16	73	11 5/8	500	E7-45TEI-84SB	33 3/16	72 5/16	12 1/8	507
90	E6-45TEI-90SB	34 1/4	77 13/16	11 5/8	529	E7-45TEI-90SB	34 5/8	77 1/8	12 1/8	536
96	E6-45TEI-96SB	35 11/16	82 5/8	11 5/8	561	E7-45TEI-96SB	36	81 15/16	12 1/8	569

CEMA E UNEQUAL TROUGHING & FLAT CARRIER IDLERS

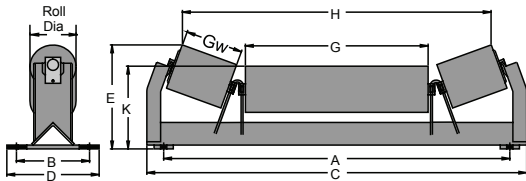

Belt Width	Standard Dimensions						Wide Base	
	A	B	C	D	G	Gw	A	C
36	45	7 1/2	49 3/8	12	23 3/4	7 1/2	51	53 1/2
42	51	7 1/2	55 3/8	12	29 3/4	7 1/2	57	59 1/2
48	57	7 1/2	61 3/8	12	35 3/4	7 1/2	63	65 1/2
54	63	7 1/2	67 3/8	12	41 3/4	7 1/2	69	71 1/2
60	69	7 1/2	73 3/8	12	47 3/4	7 1/2	75	77 1/2
66	75	8 1/2	79 3/8	12	53 3/4	7 1/2	81	83 1/2
72	81	8 1/2	85 3/8	12	59 3/4	7 1/2	87	89 1/2
78	87	8 1/2	91 3/8	12	65 3/4	7 1/2	93	95 1/2
84	93	9	97 3/8	14 1/2	71 3/4	7 1/2	99	101 1/2
90	99	9	102 7/8	14 1/2	77 3/4	7 1/2	102	107 1/2
96	105	9	109 3/8	14 1/2	83 3/4	7 1/2	111	113 1/2

20° UNEQUAL TROUGHING IDLER

Belt Width	6" Roll Diameter					7" Roll Diameter				
	Part Number	E	H	K	WT	Part Number	E	H	K	WT
36	E6-20TU-36SB	13 1/2	40 3/16	10 3/4	125	E7-20TU-36SB	13 15/16	39 13/16	11 1/4	130
42	E6-20TU-42SB	13 1/2	46 3/16	10 3/4	136	E7-20TU-42SB	13 15/16	45 13/16	11 1/4	145
48	E6-20TU-48SB	13 1/2	52 3/16	10 3/4	147	E7-20TU-48SB	13 15/16	51 13/16	11 1/4	158
54	E6-20TU-54SB	13 1/2	58 3/16	10 3/4	167	E7-20TU-54SB	13 15/16	57 13/16	11 1/4	179
60	E6-20TU-60SB	13 1/2	64 3/16	10 3/4	179	E7-20TU-60SB	13 15/16	63 13/16	11 1/4	191
66	E6-20TU-66SB	14 1/4	70 1/8	11 1/2	205	E7-20TU-66SB	14 3/4	69 3/4	12	218
72	E6-20TU-72SB	14 1/4	76 1/8	11 1/2	218	E7-20TU-72SB	14 3/4	75 3/4	12	232
78	E6-20TU-78SB	14 1/4	82 1/8	11 1/2	231	E7-20TU-72SB	14 3/4	81 3/4	12	246
84	E6-20TU-84SB	14 3/8	88 1/8	11 5/8	294	E7-20TU-84SB	14 13/16	87 3/4	12 1/8	310
90	E6-20TU-90SB	14 3/8	94 1/8	11 5/8	310	E7-20TU-72SB	14 13/16	93 3/4	12 1/8	327
96	E6-20TU-96SB	14 3/8	100 1/8	11 5/8	326	E7-20TU-96SB	14 13/16	99 3/4	12 1/8	343

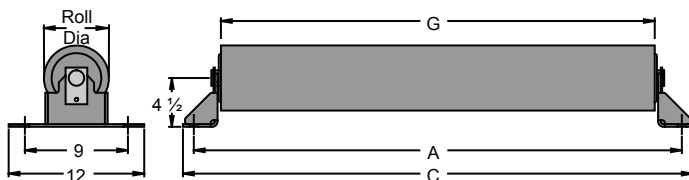

FLAT CARRIER

Belt Width	6" Roll Diameter		7" Roll Diameter		Standard Dimensions		
	Part Number	WT	Part Number	WT	A	C	G
36	E6-F-36SB	68	E7-F-36SB	75	45	47	40
42	E6-F-42SB	76	E7-F-42SB	84	51	53	46
48	E6-F-48SB	84	E7-F-48SB	92	57	59	52
54	E6-F-54SB	92	E7-F-54SB	101	63	65	58
60	E6-F-60SB	100	E7-F-60SB	110	69	71	64
66	E6-F-66SB	108	E7-F-66SB	119	75	77	70
72	E6-F-72SB	115	E7-F-72SB	127	81	83	76
78	E6-F-78SB	123	E7-F-78SB	136	87	89	82
84	E6-F-84SB	131	E7-F-84SB	145	93	95	88
90	E6-F-90SB	139	E7-F-90SB	154	99	101	94
96	E6-F-96SB	147	E7-F-96SB	163	105	107	100
102	E6-F-102SB	155	E7-F-102SB	171	111	113	106

CEMA E UNEQUAL IMPACT TROUGHING & FLAT CARRIER IDLERS

Belt Width	Standard Dimensions					Wide Base	
	A	B	C	D	G	A	C
36	45	7 1/2	49 3/8	12	23 3/4	51	53 1/2
42	51	7 1/2	55 3/8	12	29 3/4	57	59 1/2
48	57	7 1/2	61 3/8	12	35 3/4	63	65 1/2
54	63	7 1/2	67 3/8	12	41 3/4	69	71 1/2
60	69	7 1/2	73 3/8	12	47 3/4	75	77 1/2
66	75	8 1/2	79 3/8	12	53 3/4	81	83 1/2
72	81	8 1/2	85 3/8	12	59 3/4	87	89 1/2
78	87	8 1/2	91 3/8	12	65 3/4	93	95 1/2
84	93	9	97 3/8	14 1/2	71 3/4	99	101 1/2
90	99	9	102 7/8	14 1/2	77 3/4	102	107 1/2
96	105	9	109 3/8	14 1/2	83 3/4	111	113 1/2

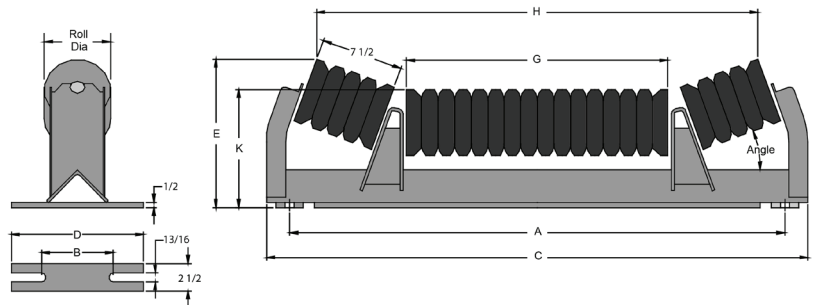

20° UNEQUAL IMPACT TROUGHING IDLER

Belt Width	6" Roll Diameter					7" Roll Diameter				
	Part Number	E	H	K	WT	Part Number	E	H	K	WT
36	E6-20TUI-36SB	13 1/2	40 3/16	10 3/4	190	E7-20TUI-36SB	13 15/16	39 13/16	11 1/4	192
42	E6-20TUI-42SB	13 1/2	46 3/16	10 3/4	203	E7-20TUI-42SB	13 15/16	45 13/16	11 1/4	206
48	E6-20TUI-48SB	13 1/2	52 3/16	10 3/4	217	E7-20TUI-48SB	13 15/16	51 13/16	11 1/4	221
54	E6-20TUI-54SB	13 1/2	58 3/16	10 3/4	240	E7-20TUI-54SB	13 15/16	57 13/16	11 1/4	244
60	E6-20TUI-60SB	13 1/2	64 3/16	10 3/4	262	E7-20TUI-60SB	13 15/16	63 13/16	11 1/4	267
66	E6-20TUI-66SB	14 1/4	70 1/8	11 1/2	293	E7-20TUI-66SB	14 3/4	69 3/4	12	298
72	E6-20TUI-72SB	14 1/4	76 1/8	11 1/2	316	E7-20TUI-72SB	14 3/4	75 3/4	12	322
78	E6-20TUI-78SB	14 1/4	82 1/8	11 1/2	374	E7-20TUI-72SB	14 3/4	81 3/4	12	380
84	E6-20TUI-84SB	14 3/8	88 1/8	11 5/8	400	E7-20TUI-84SB	14 13/16	87 3/4	12 1/8	407
90	E6-20TUI-90SB	14 3/8	94 1/8	11 5/8	426	E7-20TUI-72SB	14 13/16	93 3/4	12 1/8	433
96	E6-20TUI-96SB	14 3/8	100 1/8	11 5/8	502	E7-20TUI-96SB	14 13/16	99 3/4	12 1/8	509

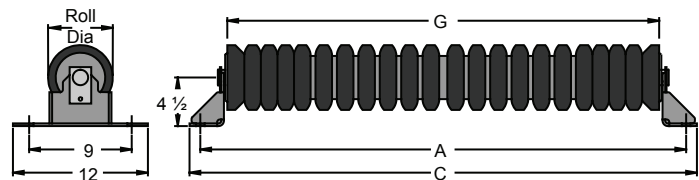

FLAT RUBBER DISC CARRIER

Belt Width	6" Roll Diameter		7" Roll Diameter		Standard Dimensions		
	Part Number	WT	Part Number	WT	A	C	G
36	E6-FRD-36SB	104	E7-FRD-36SB	106	45	47	40
42	E6-FRD-42SB	116	E7-FRD-42SB	119	51	53	46
48	E6-FRD-48SB	129	E7-FRD-48SB	132	57	59	52
54	E6-FRD-54SB	142	E7-FRD-54SB	145	63	65	58
60	E6-FRD-60SB	155	E7-FRD-60SB	159	69	71	64
66	E6-FRD-66SB	167	E7-FRD-66SB	172	75	77	70
72	E6-FRD-72SB	180	E7-FRD-72SB	185	81	83	76
78	E6-FRD-78SB	195	E7-FRD-78SB	200	87	89	82
84	E6-FRD-84SB	208	E7-FRD-84SB	214	93	95	88
90	E6-FRD-90SB	221	E7-FRD-90SB	227	99	101	94
96	E6-FRD-96SB	234	E7-FRD-96SB	240	105	107	100
102	E6-FRD-102SB	246	E7-FRD-102SB	253	111	113	106

CEMA E RETURN & V-RETURN

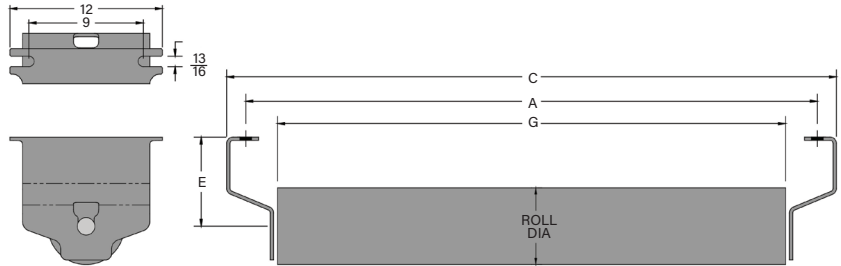

FLAT RETURN 7" DROP

Belt Width	6" Roll Diameter		7" Roll Diameter		Standard Dimensions			
	Part Number		Part Number		A	C	E	G
36	E6-R-36SB	77	E7-R-36SB	84	45	48 1/2	7	40
42	E6-R-42SB	85	E7-R-42SB	93	51	54 1/2	7	46
48	E6-R-48SB	93	E7-R-48SB	102	57	60 1/2	7	52
54	E6-R-54SB	101	E7-R-54SB	110	63	66 1/2	7	58
60	E6-R-60SB	109	E7-R-60SB	119	69	72 1/2	7	64
66	E6-R-66SB	117	E7-R-66SB	128	75	78 1/2	7	70
72	E6-R-72SB	125	E7-R-72SB	137	81	84 1/2	7	76
78	E6-R-78SB	133	E7-R-78SB	146	87	90 1/2	7	82
84	E6-R-84SB	141	E7-R-84SB	154	93	96 1/2	7	88
90	E6-R-90SB	148	E7-R-90SB	163	99	102 1/2	7	94
96	E6-R-96SB	156	E7-R-96SB	172	105	108 1/2	7	100
102	E6-R-102SB	164	E7-R-102SB	181	111	114 1/2	7	106

Belt Width	Standard Dimensions		
	A	C	G
36	45	48 3/8	19
42	51	54 3/8	22
48	57	60 3/8	25 1/8
54	63	66 3/8	28 1/8
60	69	72 3/8	31 1/8
66	75	78 3/8	34 1/4
72	81	84 3/8	37 1/4
78	87	90 3/8	40 3/8
84	93	96 3/8	43 3/8
90	99	102 3/8	46 3/8
96	105	108 3/8	49 1/2
102	111	114 3/8	52 1/2

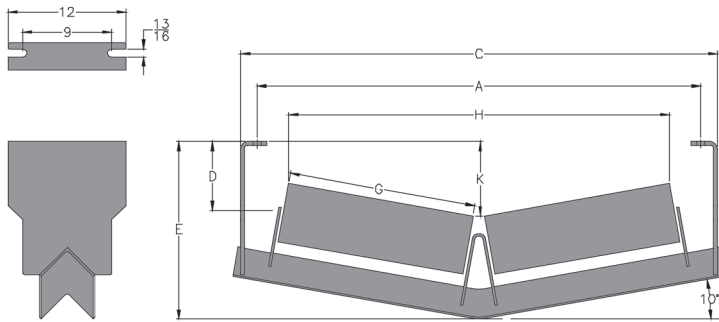

V-RETURN 7" DROP

Belt Width	6" Roll Diameter						7" Roll Diameter					
	Part Number	D	E	H	K	WT	Part Number	D	E	H	K	WT
36	E6-10VR-36SB-7	7	17 15/16	38 5/8	7 1/2	127	E7-10VR-36SB-7	7	17 15/16	38 7/16	7	136
42	E6-10VR-42SB-7	7	18 1/2	44 9/16	8	138	E7-10VR-42SB-7	7	18 1/2	44 3/8	7 9/16	148
48	E6-10VR-48SB-7	7	19	50 11/16	8 9/16	149	E7-10VR-48SB-7	7	19	50 1/2	8 1/16	160
54	E6-10VR-54SB-7	7	19 1/2	56 5/8	9 1/16	160	E7-10VR-54SB-7	7	19 1/2	56 7/16	8 9/16	172
60	E6-10VR-60SB-7	7	20 1/16	62 1/2	9 5/8	171	E7-10VR-60SB-7	7	20 1/16	62 5/16	9 1/8	184
66	E6-10VR-66SB-7	7	20 9/16	68 11/16	10 1/8	182	E7-10VR-66SB-7	7	20 9/16	68 1/2	9 5/8	197
72	E6-10VR-72SB-7	7	21 1/8	74 9/16	10 11/16	193	E7-10VR-72SB-7	7	21 1/8	74 3/8	10 3/16	208
78	E6-10VR-78SB-7	7	21 5/8	80 3/4	11 3/16	204	E7-10VR-78SB-7	7	21 5/8	80 9/16	10 11/16	220
84	E6-10VR-84SB-7	7	22 15/16	86 5/8	11 3/4	245	E7-10VR-84SB-7	7	22 15/16	86 7/16	11 1/4	263
90	E6-10VR-90SB-7	7	23 7/16	92 9/16	12 1/4	258	E7-10VR-90SB-7	7	23 7/16	92 3/8	11 3/4	277
96	E6-10VR-96SB-7	7	24	98 11/16	12 13/16	271	E7-10VR-96SB-7	7	24	98 1/2	12 5/16	291
102	E6-10VR-102SB-7	7	24 1/2	104 5/8	13 5/16	284	E7-10VR-102SB-7	7	24 1/2	104 7/16	12 15/16	305

CEMA E RETURN RUBBER DISC & V-RETURN RUBBER DISC

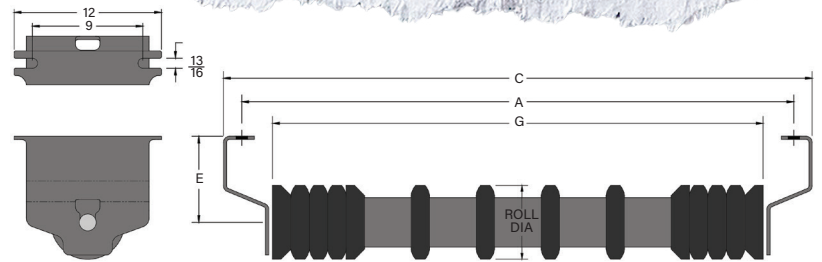

FLAT RETURN RUBBER DISC 7" DROP

Belt Width	6" Roll Diameter		7" Roll Diameter		Standard Dimensions			
	Part Number	WT	Part Number	WT	A	C	E	G
36	E6-RRD-36SB	96	E7-RRD-36SB	98	45	48 1/2	7	40
42	E6-RRD-42SB	106	E7-RRD-42SB	107	51	54 1/2	7	46
48	E6-RRD-48SB	116	E7-RRD-48SB	118	57	60 1/2	7	52
54	E6-RRD-54SB	126	E7-RRD-54SB	128	63	66 1/2	7	58
60	E6-RRD-60SB	136	E7-RRD-60SB	138	69	72 1/2	7	64
66	E6-RRD-66SB	145	E7-RRD-66SB	148	75	78 1/2	7	70
72	E6-RRD-72SB	156	E7-RRD-72SB	159	81	84 1/2	7	76
78	E6-RRD-78SB	166	E7-RRD-78SB	169	87	90 1/2	7	82
84	E6-RRD-84SB	176	E7-RRD-84SB	178	93	96 1/2	7	88
90	E6-RRD-90SB	187	E7-RRD-90SB	190	99	102 1/2	7	94
96	E6-RRD-96SB	196	E7-RRD-96SB	199	105	108 1/2	7	100
102	E6-RRD-102SB	206	E7-RRD-102SB	209	111	114 1/2	7	106

Belt Width	Standard Dimensions		
	A	C	G
36	45	48 3/8	19
42	51	54 3/8	22
48	57	60 3/8	25 1/8
54	63	66 3/8	28 1/8
60	69	72 3/8	31 1/8
66	75	78 3/8	34 1/4
72	81	84 3/8	37 1/4
78	87	90 3/8	40 3/8
84	93	96 3/8	43 3/8
90	99	102 3/8	46 3/8
96	105	108 3/8	49 1/2
102	111	114 3/8	52 1/2

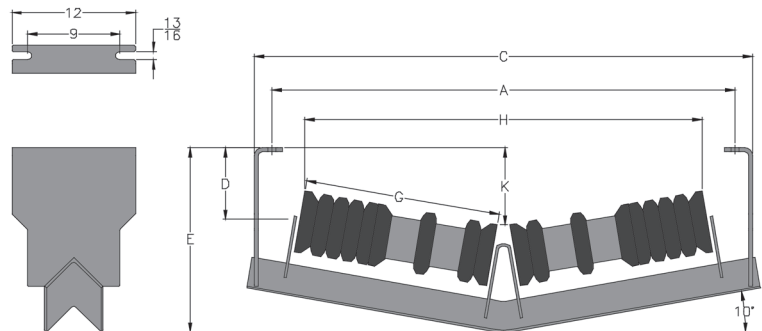

V-RETURN RUBBER DISC 7" DROP

Belt Width	6" Roll Diameter						7" Roll Diameter					
	Part Number	D	E	H	K	WT	Part Number	D	E	H	K	WT
36	E6-10VRI-36SB-7	7	17 15/16	38 5/8	7 1/2	150	E7-10VRI-36SB-7	7	17 15/16	38 7/16	7	152
42	E6-10VRI-42SB-7	7	18 1/2	44 9/16	8	164	E7-10VRI-42SB-7	7	18 1/2	44 3/8	7 9/16	166
48	E6-10VRI-48SB-7	7	19	50 11/16	8 9/16	179	E7-10VRI-48SB-7	7	19	50 1/2	8 1/16	182
54	E6-10VRI-54SB-7	7	19 1/2	56 5/8	9 1/16	192	E7-10VRI-54SB-7	7	19 1/2	56 7/16	8 9/16	194
60	E6-10VRI-60SB-7	7	20 1/16	62 1/2	9 5/8	206	E7-10VRI-60SB-7	7	20 1/16	62 5/16	9 1/8	209
66	E6-10VRI-66SB-7	7	20 9/16	68 11/16	10 1/8	221	E7-10VRI-66SB-7	7	20 9/16	68 1/2	9 5/8	224
72	E6-10VRI-72SB-7	7	21 1/8	74 9/16	10 11/16	234	E7-10VRI-72SB-7	7	21 1/8	74 3/8	10 3/16	236
78	E6-10VRI-78SB-7	7	21 5/8	80 3/4	11 3/16	249	E7-10VRI-78SB-7	7	21 5/8	80 9/16	10 11/16	251
84	E6-10VRI-84SB-7	7	22 15/16	86 5/8	11 3/4	291	E7-10VRI-84SB-7	7	22 15/16	86 7/16	11 1/4	294
90	E6-10VRI-90SB-7	7	23 7/16	92 9/16	12 1/4	308	E7-10VRI-90SB-7	7	23 7/16	92 3/8	11 3/4	311
96	E6-10VRI-96SB-7	7	24	98 11/16	12 13/16	325	E7-10VRI-96SB-7	7	24	98 1/2	12 5/16	328
102	E6-10VRI-102SB-7	7	24.1875	104 5/8	13 7/16	339	E7-10VRI-102SB-7	7	24.1875	104 7/16	12 15/16	342

CEMA E LSI & INVERTED V-RETURN

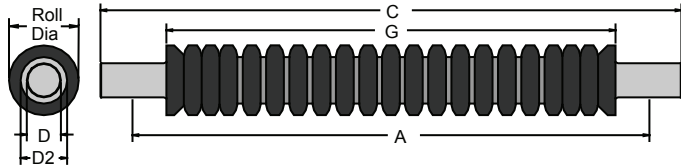

Live Shaft Idlers are available in several different configurations, with different bearing journal diameters or in steel.

Please contact PPI with your requirements.

LIVE SHAFT IMPACT FLAT CARRIER

Belt Width	6" Roll Diameter		7" Roll Diameter		Standard Dimensions				
	Part Number	WT	Part Number	WT	A	C	D	D2	G
36	E6-39LSI-36	205	E7-39LSI-36	207	45	50	2 7/16	4	38 5/8
42	E6-39LSI-42	230	E7-39LSI-42	232	51	56	2 7/16	4	44 5/8
48	E6-39LSI-48	255	E7-39LSI-48	258	57	62	2 7/16	4	50 5/8
54	E6-39LSI-54	279	E7-39LSI-54	282	63	68	2 7/16	4	56 5/8
60	E6-39LSI-60	305	E7-39LSI-60	309	69	74	2 7/16	4	62 5/8
66	E6-39LSI-66	329	E7-39LSI-66	333	75	80	2 7/16	4	68 5/8
72	E6-39LSI-72	354	E7-39LSI-72	358	81	86	2 7/16	4	74 5/8
78	E6-39LSI-78	379	E7-39LSI-78	384	87	92	2 7/16	4	80 5/8
84	E6-39LSI-84	404	E7-39LSI-84	409	93	98	2 7/16	4	86 5/8
90	E6-39LSI-90	429	E7-39LSI-90	434	99	104	2 7/16	4	92 5/8
96	E6-39LSI-96	454	E7-39LSI-96	460	105	110	2 7/16	4	98 5/8
102	E6-39LSI-102	481	E7-39LSI-102	487	111	116	2 7/16	4	104 5/8

Belt Width	Standard Dimensions		
	A	C	G
36	45	48 1/4	19 3/4
42	51	54 1/4	21 3/4
48	57	60 1/4	25 3/4
54	63	66 1/4	28
60	69	72 1/4	31 3/4
66	75	78 1/4	34 3/4
72	81	84 1/4	37 3/4
84	93	96 1/4	43 3/4
96	105	108 1/4	49 3/4
102	111	114 1/4	52 3/4

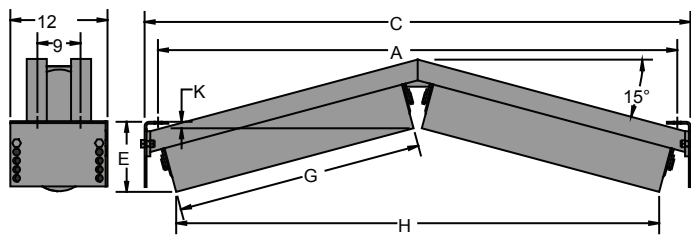

INVERTED V-RETURN

Belt Width	6" Roll Diameter					7" Roll Diameter				
	Part Number	E	H	K	WT	Part Number	E	H	K	WT
36	E6-15IVR-36SB-7	8 9/16	40 1/4	3 7/16	167	E7-15IVR-36SB-7	9 1/16	40 1/4	2 15/16	176
42	E6-15IVR-42SB-7	8 5/16	44 1/8	2 11/16	181	E7-15IVR-42SB-7	8 13/16	44 1/8	2 3/16	190
48	E6-15IVR-48SB-7	8 9/16	51 7/8	1 7/8	201	E7-15IVR-48SB-7	9 1/16	51 7/8	1 3/8	210
54	E6-15IVR-54SB-7	8 5/16	56 1/4	1 1/16	215	E7-15IVR-54SB-7	8 13/16	56 1/4	9/16	225
60	E6-15IVR-60SB-7	8 1/2	63 7/16	5/16	235	E7-15IVR-60SB-7	9	63 7/16	- 3/16	245
66	E6-15IVR-66SB-7	8 9/16	70 5/8	- 7/16	255	E7-15IVR-66SB-7	9 1/16	70 5/8	- 15/16	265
72	E6-15IVR-72SB-7	8 9/16	77 13/16	- 1 3/16	270	E7-15IVR-72SB-7	9 1/16	77 13/16	- 1 11/16	280
84	E6-15IVR-84SB-7	8 9/16	92 3/16	- 2 11/16	290	E7-15IVR-84SB-7	9 1/16	92 3/16	- 2 11/16	300
96	E6-15IVR-96SB-7	8 9/16	106 9/16	- 4 3/16	310	E7-15IVR-96SB-7	9 1/16	106 9/16	- 4 3/16	320
102	E615IVR102SB-7	8 9/16	113 3/4	- 4 15/16	325	E715IVR102SB-7	9 1/16	113 3/4	- 4 15/16	335

*Dimensions are for top position. There are four additional positions available.

CEMA E LSI & INVERTED V-RETURN RUBBER DISC

Live Shaft Idlers are available in several different configurations, with different bearing journal diameters or in steel.

Please contact PPI with your requirements.

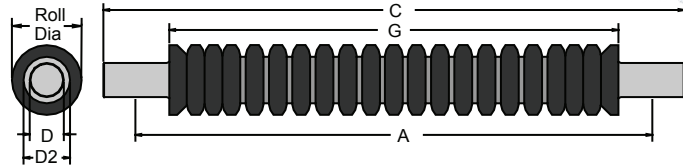

LIVE SHAFT IMPACT FLAT CARRIER

Belt Width	6" Roll Diameter		7" Roll Diameter		Standard Dimensions				
	Part Number	WT	Part Number	WT	A	C	D	D2	G
36	E6-47LSI-36	211	E7-47LSI-36	213	45	50	2 15/16	4	38 5/8
42	E6-47LSI-42	236	E7-47LSI-42	238	51	56	2 15/16	4	44 5/8
48	E6-47LSI-48	261	E7-47LSI-48	264	57	62	2 15/16	4	50 5/8
54	E6-47LSI-54	285	E7-47LSI-54	288	63	68	2 15/16	4	56 5/8
60	E6-47LSI-60	311	E7-47LSI-60	315	69	74	2 15/16	4	62 5/8
66	E6-47LSI-66	335	E7-47LSI-66	339	75	80	2 15/16	4	68 5/8
72	E6-47LSI-72	360	E7-47LSI-72	364	81	86	2 15/16	4	74 5/8
78	E6-47LSI-78	385	E7-47LSI-78	390	87	92	2 15/16	4	80 5/8
84	E6-47LSI-84	410	E7-47LSI-84	415	93	98	2 15/16	4	86 5/8
90	E6-47LSI-90	435	E7-47LSI-90	440	99	104	2 15/16	4	92 5/8
96	E6-47LSI-96	460	E7-47LSI-96	466	105	110	2 15/16	4	98 5/8
102	E6-47LSI-102	487	E7-47LSI-102	493	111	116	2 15/16	4	104 5/8

Belt Width	Standard Dimensions		
	A	C	G
36	45	47	19 3/4
42	51	53	21 3/4
48	57	59	25 3/4
54	63	65	28
60	69	71	31 3/4
66	75	78 1/4	34 3/4
72	81	84 1/4	37 3/4
84	93	108 1/4	43 3/4
96	105	108 3/8	49 3/4
102	111	114 3/8	52 3/4

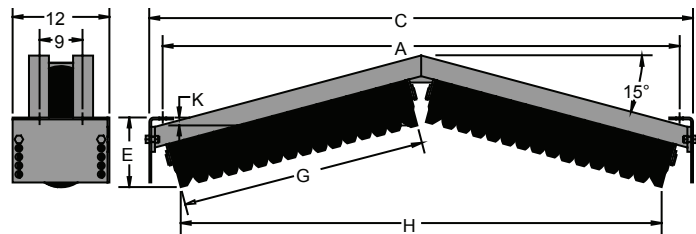

INVERTED V-RETURN RUBBER DISC

Belt Width	6" Roll Diameter					7" Roll Diameter				
	Part Number	E	H	K	WT	Part Number	E	H	K	WT
36	E615IVRI36SB-7	8 9/16	40 1/4	3 7/16	180	E715IVRI36SB-7	9 1/16	40 1/4	2 15/16	190
42	E615IVRI42SB-7	8 5/16	44 1/8	2 11/16	194	E715IVRI42SB-7	8 13/16	44 1/8	2 3/16	204
48	E615IVRI48SB-7	8 9/16	51 7/8	1 7/8	221	E715IVRI48SB-7	9 1/16	51 7/8	1 3/8	231
54	E615IVRI54SB-7	8 5/16	56 1/4	1 1/16	238	E715IVRI54SB-7	8 13/16	56 1/4	9/16	248
60	E615IVRI60SB-7	8 1/2	63 7/16	5/16	261	E715IVRI60SB-7	9	63 7/16	- 3/16	271
66	E615IVRI66SB-7	8 9/16	70 5/8	- 7/16	284	E715IVRI66SB-7	9 1/16	70 5/8	- 15/16	294
72	E615IVRI72SB-7	8 9/16	77 13/16	- 1 3/16	302	E715IVRI72SB-7	9 1/16	77 13/16	- 1 11/16	312
84	E615IVRI84SB-7	8 9/16	92 3/16	- 2 11/16	328	E715IVRI84SB-7	9 1/16	92 3/16	- 3 3/16	338
96	E615IVRI96SB-7	8 9/16	106 9/16	- 4 3/16	354	E715IVRI96SB-7	9 1/16	106 9/16	- 4 11/16	364
102	E615IVRI102SB-7	8 9/16	113 3/4	- 4 15/16	373	E715IVRI102SB-7	9 1/16	113 3/4	- 5 7/16	383

*Dimensions are for top position. There are four additional positions available.

CEMA E SELF-ALIGNER - TROUGHING IDLERS

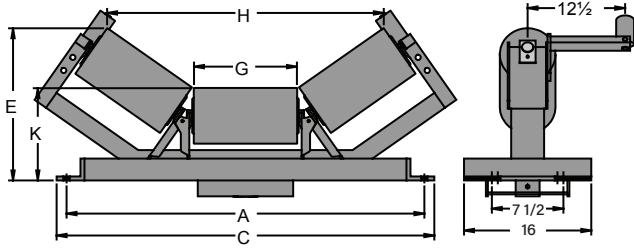

Belt Width	Standard Dimensions			Wide Base	
	A	C	G	Aw	Cw
36	45	47 1/2	13	51	53 1/2
42	51	53 1/2	15	57	59 1/2
48	57	59 1/2	17 3/4	63	65 1/2
54	63	65 1/2	19 3/4	69	71 1/2
60	69	71 1/2	21 3/4	75	77 1/2
66	75	77 1/2	23 3/4	81	83 1/2
72	81	83 1/2	25 3/4	87	89 1/2
78	87	89 1/2	27 3/4	93	95 1/2
84	93	95 1/2	29 3/4	99	101 1/2
90	99	101 1/2	31 3/4	102	107 1/2
96	105	107 1/2	33 3/4	111	113 1/2

20° TROUGHING EQUAL SELF-ALIGNER

Belt Width	6" Roll Diameter					7" Roll Diameter				
	Part Number	E	H	K	WT	Part Number	E	H	K	WT
36	E6-20TESA-36SB	15 3/4	39 3/4	10 7/8	200	E7-20TESA-36SB	16 1/4	39 3/8	11 3/8	209
42	E6-20TESA-42SB	16 7/16	45 1/2	10 7/8	215	E7-20TESA-42SB	16 15/16	45 1/8	11 3/8	225
48	E6-20TESA-48SB	17.4375	53 7/16	10 7/8	254	E7-20TESA-48SB	17 15/16	53 1/16	11 3/8	265
54	E6-20TESA-54SB	18 1/16	59 3/16	10 7/8	278	E7-20TESA-54SB	18 9/16	58 7/8	11 3/8	290
60	E6-20TESA-60SB	18 3/4	64 15/16	10 7/8	303	E7-20TESA-60SB	19 1/4	64 9/16	11 3/8	315
66	E6-20TESA-66SB	20 9/16	70 11/16	11 5/8	336	E7-20TESA-66SB	21 1/16	70 5/16	12 1/8	349
72	E6-20TESA-72SB	21 1/4	76 7/16	11 5/8	387	E7-20TESA-72SB	21 3/4	76 1/8	12 1/8	402
78	E6-20TESA-78SB	21 7/16	82 3/16	11 5/8	408	E7-20TESA-78SB	21 15/16	81 15/16	12 1/8	423
84	E6-20TESA-84SB	22 5/8	87 15/16	11 3/4	429	E7-20TESA-84SB	23 1/8	87 9/16	12 1/4	445
90	E6-20TESA-90SB	23 5/16	93 3/4	11 3/4	450	E7-20TESA-90SB	23 13/16	93 3/8	12 1/4	467
96	E6-20TESA-96SB	23 15/16	99 1/2	11 3/4	471	E7-20TESA-96SB	24 7/16	99 1/8	12 1/4	489

35° TROUGHING EQUAL SELF-ALIGNER

Belt Width	6" Roll Diameter					7" Roll Diameter				
	Part Number	E	H	K	WT	Part Number	E	H	K	WT
36	E6-35TESA-36SB	18 3/4	35 3/8	10 7/8	204	E7-35TESA-36SB	19 3/16	34 3/4	11 3/8	212
42	E6-35TESA-42SB	19 7/8	40 5/8	10 7/8	219	E7-35TESA-42SB	20 5/16	40 1/16	11 3/8	228
48	E6-35TESA-48SB	21 7/16	47 7/8	10 7/8	258	E7-35TESA-48SB	21 7/8	47 5/16	11 3/8	269
54	E6-35TESA-54SB	22 9/16	53 3/16	10 7/8	282	E7-35TESA-54SB	23	52 5/8	11 3/8	293
60	E6-35TESA-60SB	23 3/4	58 7/16	10 7/8	306	E7-35TESA-60SB	24 3/16	57 7/8	11 3/8	318
66	E6-35TESA-66SB	26 1/16	63 3/4	11 5/8	341	E7-35TESA-66SB	26 1/2	63 1/8	12 1/8	354
72	E6-35TESA-72SB	27 3/16	69	11 5/8	392	E7-35TESA-72SB	27 5/8	68 7/16	12 1/8	406
78	E6-35TESA-78SB	27 7/8	74 1/4	11 5/8	413	E7-35TESA-78SB	28.3125	73 11/16	12 1/8	428
84	E6-35TESA-84SB	29 7/16	79 9/16	11 3/4	434	E7-35TESA-84SB	29 7/8	78 15/16	12 1/4	450
90	E6-35TESA-90SB	30 5/8	84 7/8	11 3/4	455	E7-35TESA-90SB	31 1/16	84 1/4	12 1/4	472
96	E6-35TESA-96SB	31 3/4	90 1/8	11 3/4	476	E7-35TESA-96SB	32 3/16	89 1/2	12 1/4	493

45° TROUGHING EQUAL SELF-ALIGNER

Belt Width	6" Roll Diameter					7" Roll Diameter				
	Part Number	E	H	K	WT	Part Number	E	H	K	WT
36	E6-45TESA-36SB	20 1/2	32 9/16	10 7/8	208	E7-45TESA-36SB	20 7/8	31 7/8	11 3/8	216
42	E6-45TESA-42SB	21 15/16	37 3/8	10 7/8	223	E7-45TESA-42SB	22 5/16	36 11/16	11 3/8	232
48	E6-45TESA-48SB	23 1/2	44 1/16	10 7/8	262	E7-45TESA-48SB	23 7/8	43 5/16	11 3/8	272
54	E6-45TESA-54SB	25 5/16	48 7/8	10 7/8	279	E7-45TESA-54SB	25 11/16	48 1/8	11 3/8	291
60	E6-45TESA-60SB	26 11/16	53 11/16	10 7/8	301	E7-45TESA-60SB	27 1/16	52 15/16	11 3/8	313
66	E6-45TESA-66SB	29 1/4	58 9/16	11 5/8	339	E7-45TESA-66SB	29 5/8	57 13/16	12 1/8	352
72	E6-45TESA-72SB	30 5/8	63 3/8	11 5/8	397	E7-45TESA-72SB	31	62 5/8	12 1/8	411
78	E6-45TESA-78SB	31 5/8	68 3/16	11 5/8	418	E7-45TESA-78SB	32	67 1/2	12 1/8	433
84	E6-45TESA-84SB	33 7/16	73	11 3/4	439	E7-45TESA-84SB	33 13/16	72 5/16	12 1/4	454
90	E6-45TESA-90SB	34 13/16	77 13/16	11 3/4	459	E7-45TESA-90SB	35 1/4	77 1/8	12 1/4	476
96	E6-45TESA-96SB	36 11/83	82 5/8	11 3/4	480	E7-45TESA-96SB	36 11/16	81 15/16	12 1/4	498

CEMA E RETURN SELF-ALIGNER

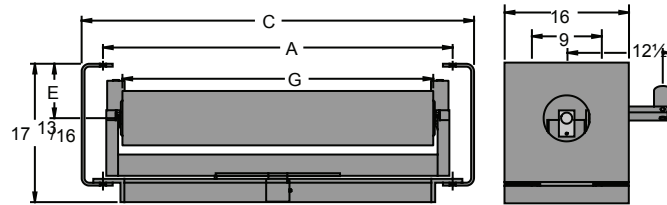

RETURN SELF-ALIGNER 7" DROP

Belt Width	6" Roll Diameter		7" Roll Diameter		Standard Dimensions			Wide Base	
	Part Number	WT	Part Number	WT	A	C	G	Aw	Cw
36	E6-RSA-36SB	358	E7-RSA-36SB	365	45	50 1/2	40	51	56 1/2
42	E6-RSA-42SB	378	E7-RSA-42SB	386	51	56 1/2	46	57	62 1/2
48	E6-RSA-48SB	396	E7-RSA-48SB	404	57	62 1/2	52	63	68 1/2
54	E6-RSA-54SB	412	E7-RSA-54SB	422	63	68 1/2	58	69	74 1/2
60	E6-RSA-60SB	433	E7-RSA-60SB	443	69	74 1/2	64	75	80 1/2
66	E6-RSA-66SB	449	E7-RSA-66SB	461	75	80 1/2	70	81	86 1/2
72	E6-RSA-72SB	466	E7-RSA-72SB	478	81	86 1/2	76	87	92 1/2
78	E6-RSA-78SB	482	E7-RSA-78SB	495	87	92 1/2	82	93	98 1/2
84	E6-RSA-84SB	503	E7-RSA-84SB	517	93	98 1/2	88	99	104 1/2
90	E6-RSA-90SB	520	E7-RSA-90SB	534	99	104 1/2	94	105	110 1/2
96	E6-RSA-96SB	536	E7-RSA-96SB	552	105	110 1/2	100	111	116 1/2

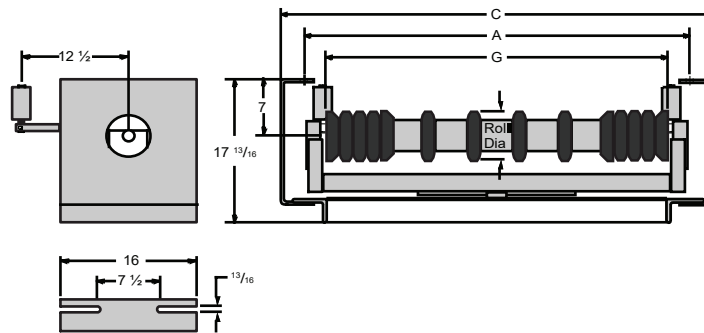

RETURN RUBBER DISC SELF-ALIGNER 7" DROP

Belt Width	6" Roll Diameter		7" Roll Diameter		Standard Dimensions			Wide Base	
	Part Number	WT	Part Number	WT	A	C	G	Aw	Cw
36	E6-RRDSA-36SB	376	E7-RRDSA-36SB	378	45	50 1/2	40	51	56 1/2
42	E6-RRDSA-42SB	398	E7-RRDSA-42SB	400	51	56 1/2	46	57	62 1/2
48	E6-RRDSA-48SB	419	E7-RRDSA-48SB	421	57	62 1/2	52	63	68 1/2
54	E6-RRDSA-54SB	437	E7-RRDSA-54SB	439	63	68 1/2	58	69	74 1/2
60	E6-RRDSA-60SB	460	E7-RRDSA-60SB	462	69	74 1/2	64	75	80 1/2
66	E6-RRDSA-66SB	478	E7-RRDSA-66SB	480	75	80 1/2	70	81	86 1/2
72	E6-RRDSA-72SB	497	E7-RRDSA-72SB	500	81	86 1/2	76	87	92 1/2
78	E6-RRDSA-78SB	515	E7-RRDSA-78SB	518	87	92 1/2	82	93	98 1/2
84	E6-RRDSA-84SB	538	E7-RRDSA-84SB	541	93	98 1/2	88	99	104 1/2
90	E6-RRDSA-90SB	557	E7-RRDSA-90SB	560	99	104 1/2	94	105	110 1/2
96	E6-RRDSA-96SB	575	E7-RRDSA-96SB	579	105	110 1/2	100	111	116 1/2

MOUNTING DETAILS FOOTPADS & BRACKETS

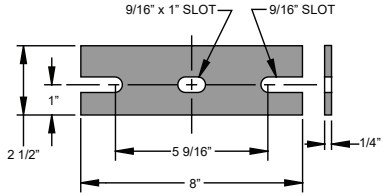
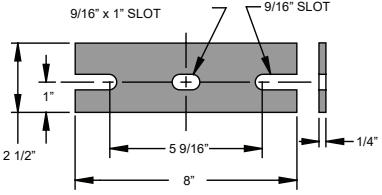
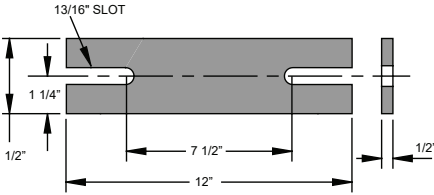
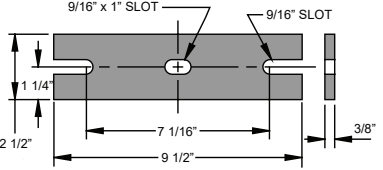
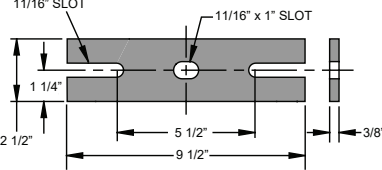
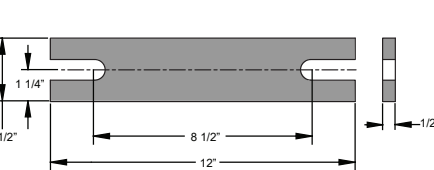
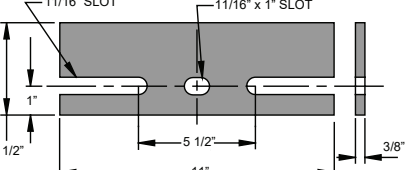
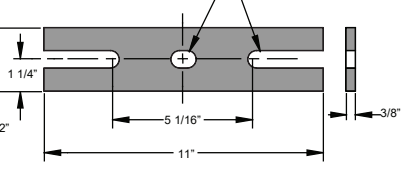
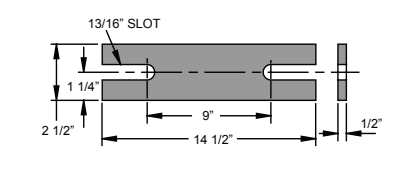
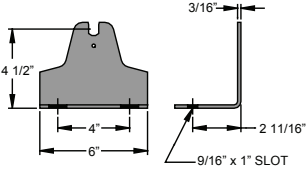
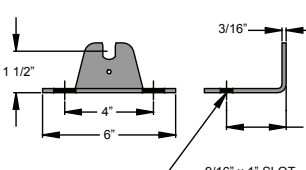
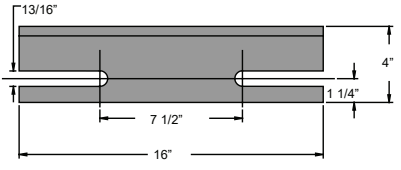
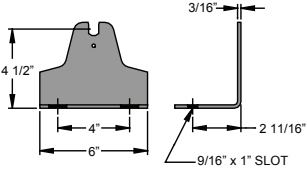
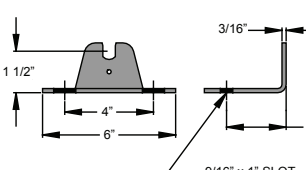
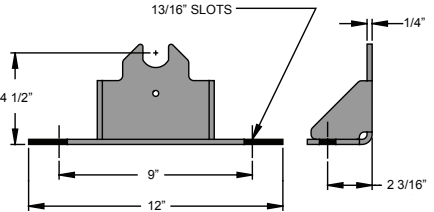
CEMA B Details	CEMA C/D Details	CEMA E Details
<p>Trougher 14-36 belts</p> 	<p>Trougher 18-24 belts</p> 	<p>Trougher 36-60 belts</p> 
<p>Trougher 42-48 belts</p> 	<p>Trougher 30-48 belts</p> 	<p>E 66\" to 78\" belts</p> 
<p>B,C,D TESA, FSA</p> 	<p>C 54\" and 60\" belts</p> 	<p>Trougher E 84-96 belts</p> 
<p>B,C,D 4 1/2\" Endstand (standard) - #01990</p> 	<p>B,C,D 1 1/2\" Endstand (optional) - #15001</p> 	<p>E Self-Aligner</p> 
<p>B,C,D 4 1/2\" Endstand (standard) - #01990</p> 	<p>B,C,D 1 1/2\" Endstand (optional) - #15001</p> 	<p>4 1/2\" E - Endstand (standard) - #42330</p> 

MOUNTING DETAILS FOOTPADS & BRACKETS

B,C - 4½" Drop Bracket (standard) - #14200

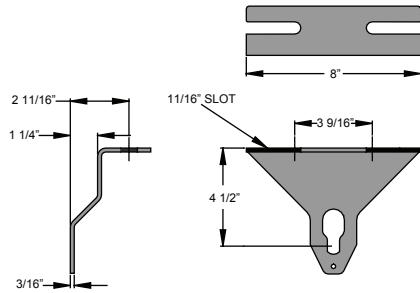

B,C - 1½" Drop Bracket (optional) - #02200

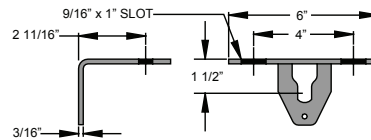

D - 4½" Drop Bracket (standard) - #14206

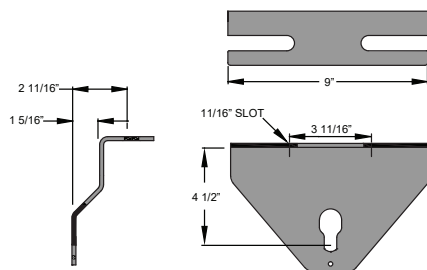

D - 1½" Drop Bracket (optional) - #02201

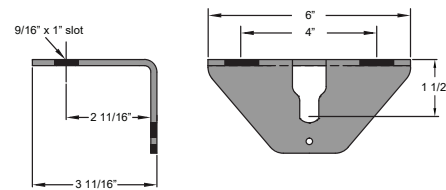

7" E - Drop Bracket (standard) - #41210

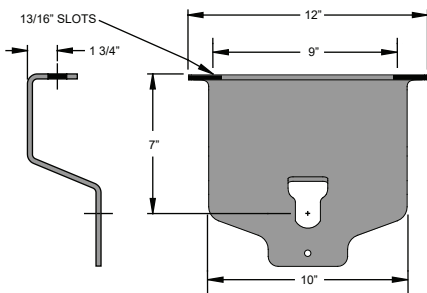

4½" E Drop Bracket (optional) - #41213

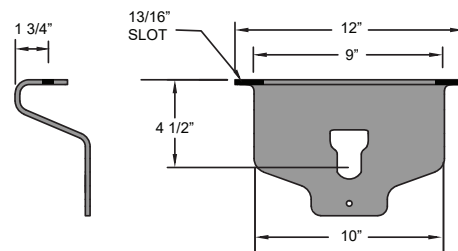

1½" E - Drop Bracket (optional) - #41211

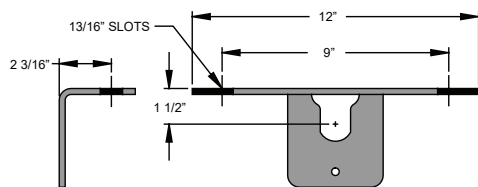

C,D V-Return Foot Pad

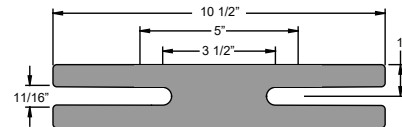

B, C, D 4½" Belt Saver II Drop Bracket (optional) - #14207

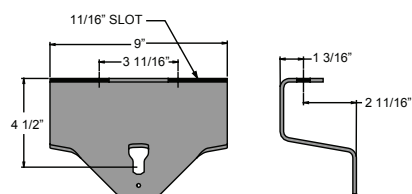

E V-Return Foot Pad

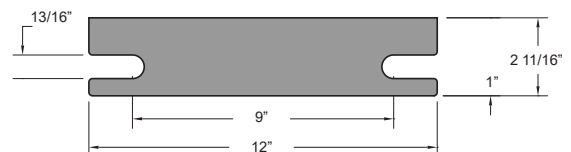

MOUNTING DETAILS FOOTPADS & BRACKETS

2" CIT Drop Bracket (standard) - #24390

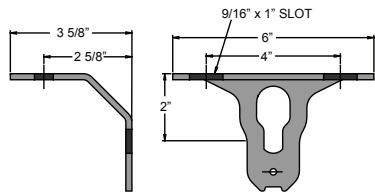

4" CIT Web Drop Bracket (optional) - #30640

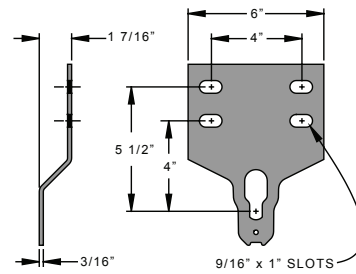

CEMA C - CIT End Bracket (detail end view)

See pages 28 & 29
for complete frame
dimensions

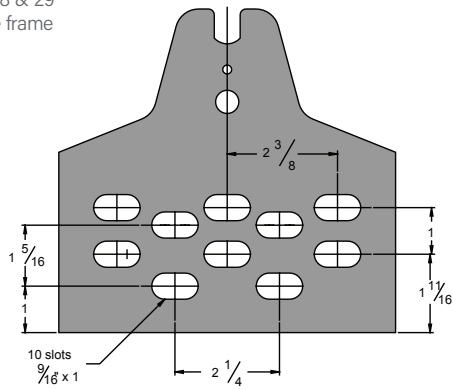

4 1/2" C/D - IVR Drop Bracket

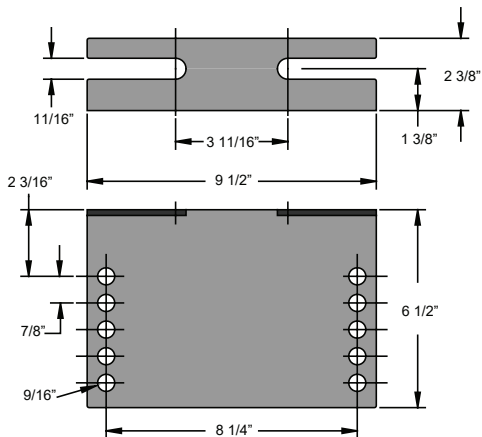

7" E - IVR Drop Bracket

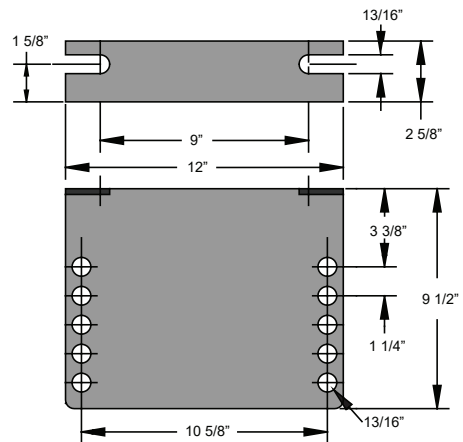

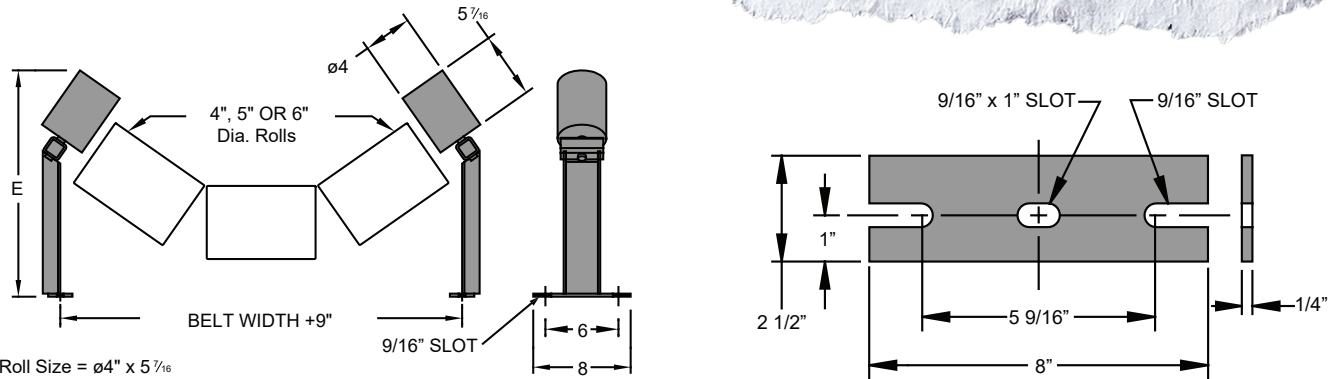

GRT - GUIDE ROLLER TROUGHED BELT WITH MOUNTING BRACKET

Belt Width	20° Trough				35° Trough				45° Trough			
	Description	Part Number	Height "E"	WT	Description	Part Number	Height "E"	WT	Description	Part Number	Height "E"	WT
14	GRT-20-14	13911	11 13/16	7	GRT-35-14	14161	13 13/16	7	GRT-45-14	23390	14 13/16	8
16	GRT-20-16	13912	11 13/16	7	GRT-35-16	14162	13 13/16	7	GRT-45-16	23391	14 13/16	8
18	GRT-20-18	13900	13 11/16	7	GRT-35-18	14110	16 1/8	8	GRT-45-18	23392	17 1/8	9
20	GRT-20-20	13960	14	7	GRT-35-20	14170	16 5/8	8	GRT-45-20	23393	17 5/16	9
24	GRT-20-24	13910	14 7/16	7	GRT-35-24	14120	17 3/8	9	GRT-45-24	23394	18 11/16	10
30	GRT-20-30	13920	15 3/16	8	GRT-35-30	14130	18 5/8	9	GRT-45-30	23395	20 3/16	10
36	GRT-20-36	13930	15 15/16	8	GRT-35-36	14140	19 3/16	9	GRT-45-36	23396	22 1/16	14
42	GRT-20-42	13940	17 1/16	8	GRT-35-42	14150	21 1/2	10	GRT-45-42	24570	24 5/8	15
48	GRT-20-48	13950	17 13/16	9	GRT-35-48	14160	22 3/4	10	GRT-45-48	23397	25 1/16	16
54	GRT-20-54	28040	18 1/2	9	GRT-35-54	14163	23 15/16	14	GRT-45-54	23398	26 11/16	17
60	GRT-20-60	13913	19 1/8	9	GRT-35-60	14164	25 1/8	15	GRT-45-60	22740	28 1/8	18
72	GRT-20-72	13914	20 11/16	10	GRT-35-72	14165	27 9/16	17	GRT-45-72	23399	31 1/8	20

GRF - GUIDE ROLLER FLAT BELT WITH MOUNTING BRACKET

Part Number	WT
GRF	6

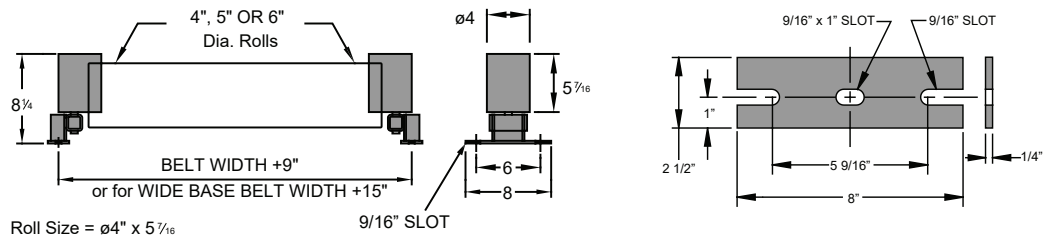

GRR - GUIDE ROLLER RETURN WITH MOUNTING BRACKET

Part Number	Drop "E"	WT
GRR	4 1/2	6
GRR-1	11/2	5

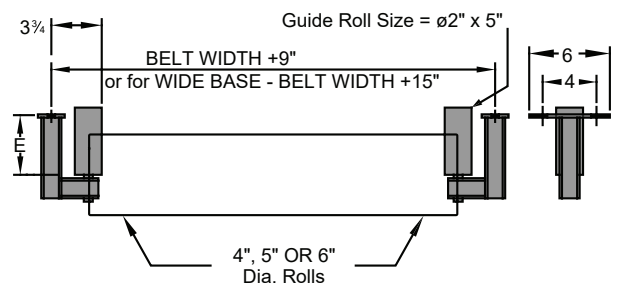
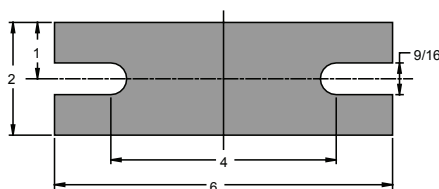

Guide rollers above are sold individually, not by the pair. Guide rollers to be set clear of the belt edges so as to restrain the belt only when it strays. Guide rollers are not intended for use as belt training devices. Constant roller contact with the belt could result in belt and roller damage.

STUB IDLERS

0° STUB IDLER ASSEMBLY

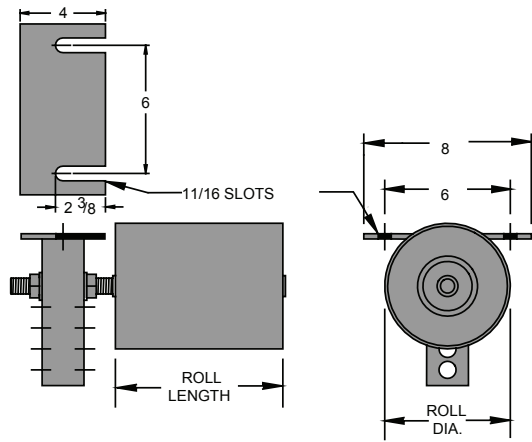

5° STUB IDLER ASSEMBLY

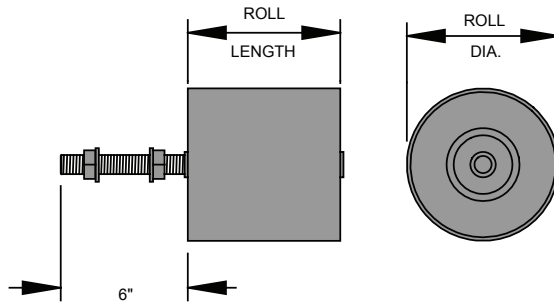
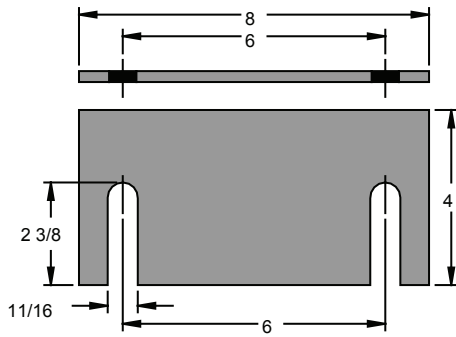
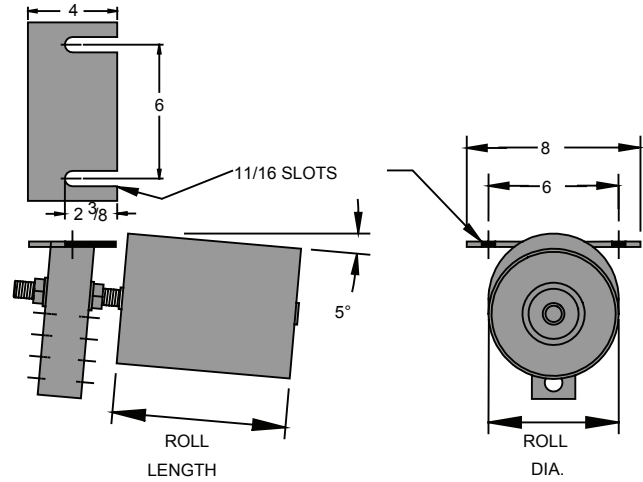

STUB IDLER PART NUMBERS

Diameter	Roll Length	3/4" Shaft Diameter			1" Shaft Diameter		
		Roll P/N	0° Assembly P/N	5° Assembly P/N	Roll P/N	0° Assembly P/N	5° Assembly P/N
4"	4 1/2"	C4-STUB-4.50	C4-OSTUB-4.50	C4-5STUB-4.50	-	-	-
	5"	C4-STUB-5.00	C4-OSTUB-5.00	C4-5STUB-5.00	-	-	-
	6"	C4-STUB-6.00	C4-OSTUB-6.00	C4-5STUB-6.00	-	-	-
	7"	C4-STUB-7.00	C4-OSTUB-7.00	C4-5STUB-7.00	-	-	-
	8"	C4-STUB-8.00	C4-OSTUB-8.00	C4-5STUB-8.00	-	-	-
5"	4 1/2"	C5-STUB-4.50	C5-OSTUB-4.50	C5-5STUB-4.50	-	-	-
	5"	C5-STUB-5.00	C5-OSTUB-5.00	C5-5STUB-5.00	D5-STUB-5.00	D5-OSTUB-5.00	D5-5STUB-5.00
	6"	C5-STUB-6.00	C5-OSTUB-6.00	C5-5STUB-6.00	D5-STUB-6.00	D5-OSTUB-6.00	D5-5STUB-6.00
	7"	C5-STUB-7.00	C5-OSTUB-7.00	C5-5STUB-7.00	D5-STUB-7.00	D5-OSTUB-7.00	D5-5STUB-7.00
	8"	C5-STUB-8.00	C5-OSTUB-8.00	C5-5STUB-8.00	D5-STUB-8.00	D5-OSTUB-8.00	D5-5STUB-8.00
6"	4 1/2"	C6-STUB-4.50	C6-OSTUB-4.50	C6-5STUB-4.50	-	-	-
	5"	C6-STUB-5.00	C6-OSTUB-5.00	C6-5STUB-5.00	D6-STUB-5.00	D6-OSTUB-5.00	D6-5STUB-5.00
	6"	C6-STUB-6.00	C6-OSTUB-6.00	C6-5STUB-6.00	D6-STUB-6.00	D6-OSTUB-6.00	D6-5STUB-6.00
	7"	C6-STUB-7.00	C6-OSTUB-7.00	C6-5STUB-7.00	D6-STUB-7.00	D6-OSTUB-7.00	D6-5STUB-7.00
	8"	C6-STUB-8.00	C6-OSTUB-8.00	C6-5STUB-8.00	D6-STUB-8.00	D6-OSTUB-8.00	D6-5STUB-8.00
Mounting Bracket only P/N			34600	34610		34615	31582

Note: Mounting brackets have 5 mounting positions on 1" centers. Roll P/N includes roll, shaft, and nuts.

SPECIALTY PRODUCTS

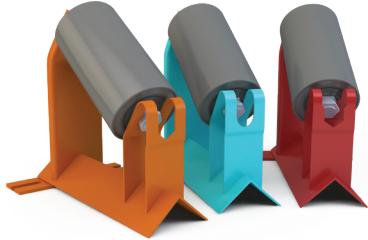

RETRO ROLLS® Fit different brands of CEMA B, C, D & E as well as ISO idlers.

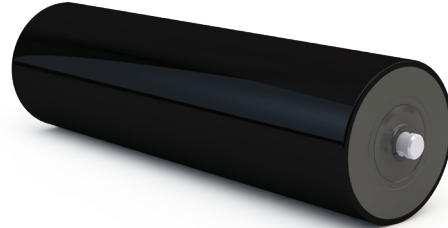

ROLL COVERINGS are available in Poly, SBR, Neoprene to extend the life of a PPI roll.

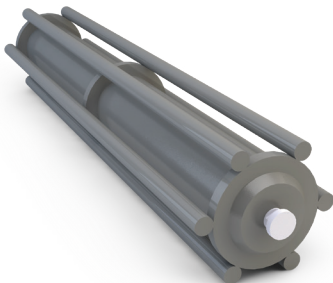

BEATER BAR RETURN
PPI problem solver reduces material buildup.



RETURN RUBBER GROOVED
Rugged 1-piece construction for abusive situations.

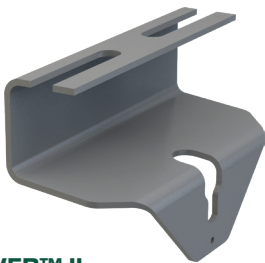

BELTSAVER™ II
Protect your belt from rubbing, uses standard rolls.

SMART ROLL™

Belt speed indicator with sensor protection, overload protection, multifunction, maintenance-free.

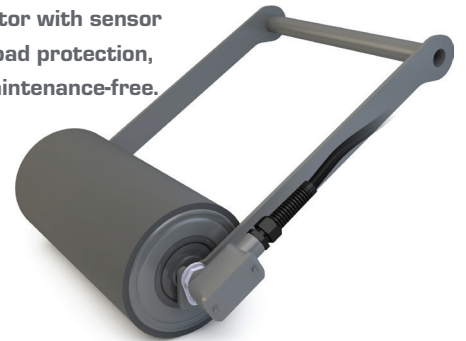

SCALE QUALITY ROLLS

PPI produces scale quality rolls with TIR of .015" or less.

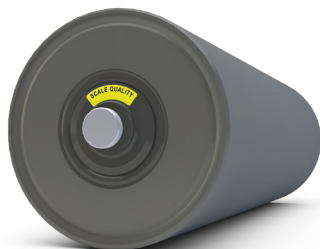

RETURN ROLL GUARD

Available in 1½ & 4½ drop, as well as heavy duty.

SPECIALTY PRODUCTS



TRUE IMPACT SYSTEM
Rugged multi-action shock absorption system that reduces impact damage to your belt.



EZ SLIDER SERIES
Rugged Retro-Fit sliders that fit standard PPI frames.

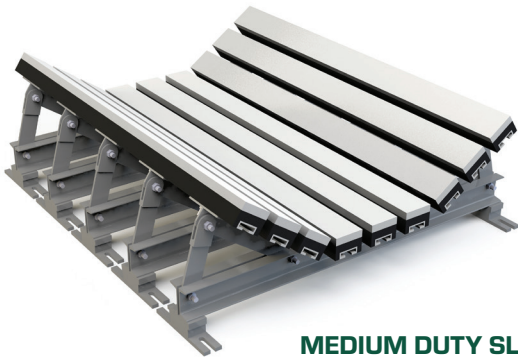

MEDIUM DUTY SLIDER BED
This bed is an ideal combination of impact absorption and belt support that provides a tight seal for skirt boarding.

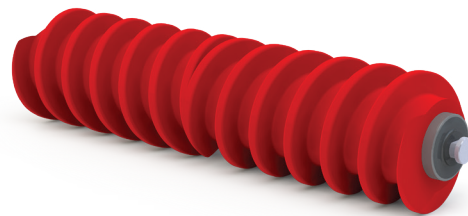

SPIRAL URETHANE ROLL
Ever changing point of contact on the belt surface that provides cleaning action without beating the belt.

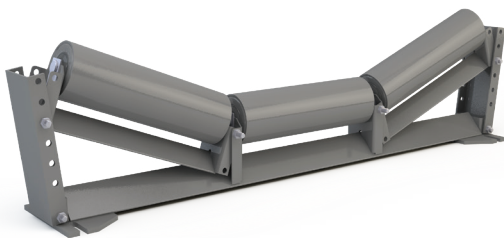

TRANSITION EQUAL TROUGHING IDLERS - TET
Adjustable troughing angle for belt transitions.

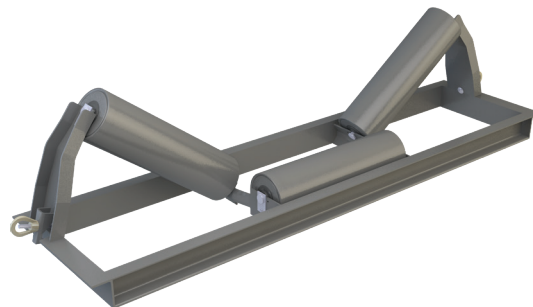

WIRE ROPE IDLERS
Attach to steel cable or rigid channel frames.

TERMS & CONDITIONS

APPLICABILITY:	These terms and conditions of sale (these "Terms") are the only terms which govern the sale of the goods ("Goods") by Precision, Inc. ("Seller") to the purchaser of the Goods ("Buyer"). The accompanying Buyer's purchase order (the "PO") and these Terms (collectively, this "Agreement") comprise the entire agreement between the parties, and supersede all prior or contemporaneous understandings, agreements, negotiations, representations and warranties, and communications, both written and oral. These Terms prevail over any of Seller's general terms and conditions of purchase. POs SHALL BE PROMPTLY FORWARDED TO SELLER ELECTRONICALLY AND ARE SUBJECT TO SELLER'S ACCEPTANCE AT ITS OFFICE IN PELLA, IOWA BEFORE BECOMING BINDING ON SELLER.
DELIVERY:	Subject to the availability of finished Goods and unless otherwise specified by Buyer and agreed to by Seller, the Goods will be delivered within a reasonable time after receipt of the PO. Delivery shall be FOB shipping point (the "Shipping Point"). Title and risk of loss pass to Buyer upon delivery of the Goods to the Shipping Point. All shipments are insured at Buyer's expense and made at Buyer's risk and cost.
SHIPPING TERMS AND PACKAGING:	The method and route of shipment, including packaging are at Seller's discretion unless otherwise specified by Buyer and agreed to by Seller.
INSPECTION AND REJECTION OF NONCONFORMING GOODS:	Buyer shall inspect the Goods within thirty (30) days of receipt ("Inspection Period"). Buyer will be deemed to have accepted the Goods unless it notifies Seller in writing of any Nonconforming Goods during the Inspection Period. "Nonconforming Goods" means Goods that are different from those identified in the PO. Seller shall, at its option: (i) replace Nonconforming Goods with conforming Goods, or (ii) credit or refund the Price for such Nonconforming Goods. If Seller elects to replace the Nonconforming Goods, Seller shall, after receiving Buyer's shipment of Nonconforming Goods, ship to Buyer, at Buyer's expense and risk of loss, the conforming Goods. Any terms and conditions in the PO which deletes from, alters, or adds to these Terms will not be binding upon Seller unless such terms and conditions are expressly agreed to in writing by Seller.
PRICE:	Buyer shall purchase the Goods from Seller at the prices (the "Price") agreed upon between Buyer and Seller. All prices are subject to change without notice. All Prices are exclusive of any local, state, or federal taxes.
PAYMENT TERMS:	Unless otherwise agreed by Buyer and Seller, payment shall be net thirty (30) days from the date of Seller's invoice. As collateral security for the payment of the Price, Buyer hereby grants to Seller a lien on and security interest in and to all of the right, title and interest of Buyer in the Goods, wherever located, and whether now existing or hereafter acquired, and in all accessions thereto and replacements or modifications thereof, as well as all proceeds therefrom. The security interest granted under this provision constitutes a purchase money security interest under the Iowa Uniform Commercial Code. In the event an order is received based on the PO and is later cancelled, placed on hold or delayed due to a lack of Buyer-supplied information, Seller reserves the right to add storage charges and/or invoices for total payment for Goods in process or completed. In the event of cancellation of an order, Buyer will be liable for the reasonable costs and expenses incurred by Seller prior to notice of cancellation of the order. Cancellation requests from the Buyer require the written consent of Seller.
NON-DELIVERY:	The Seller shall not be liable for any non-delivery of Goods (even if caused by Seller's negligence) unless Buyer gives written notice to Seller of the non-delivery within five (5) days of the date when the Goods would have been received in the ordinary course of business. Any liability of Seller for non-delivery of the Goods shall be limited to replacing the Goods within a reasonable time or adjusting the invoice respecting such Goods to reflect the actual quantity delivered.
LIMITED WARRANTY:	Seller warrants to Buyer that: 1) for a period of twelve (12) months from the date of delivery of the Goods other than "specialty pulleys", Engineered Class pulleys, or ProDuty pulleys; 2) the lesser of twelve (12) months or two thousand (2,000) hours of use for "specialty pulleys"; 3) two (2) years for Engineered Class pulleys or 4) ten (10) years for ProDuty pulleys ("Warranty Period"), that such Goods will be free from material defects in material and workmanship, when used under normal load and operating conditions and installed and maintained properly. Warranties shall not apply to any Goods which have been subject to misuse, misapplication, accident, neglect, modification, repair, improper maintenance, improper storage or improper installation. Misuse includes, but is not limited to, deterioration by chemical action, wear by presence of abrasive material, improper lubrication. System design is the sole responsibility of Buyer and excessive or undefined loads shall not be warranted. EXCEPT FOR THE WARRANTY SET FORTH IN THIS SECTION 8, SELLER MAKES NO WARRANTY WHATSOEVER WITH RESPECT TO THE GOODS, INCLUDING ANY (a) WARRANTY OF MERCHANTABILITY; (b) WARRANTY OF FITNESS FOR A PARTICULAR PURPOSE (EXCEPT AS MAY BE AGREED TO BETWEEN BUYER AND SELLER); (c) WARRANTY OF TITLE; OR (d) WARRANTY AGAINST INFRINGEMENT OF INTELLECTUAL PROPERTY RIGHTS OF A THIRD PARTY; WHETHER EXPRESS OR IMPLIED BY LAW, COURSE OF DEALING, COURSE OF PERFORMANCE, USAGE OF TRADE OR OTHERWISE. Products manufactured by a third party ("Third Party Product") may be incorporated in, attached to or packaged together with, the Goods. SELLER MAKES NO REPRESENTATIONS OR WARRANTIES WITH RESPECT TO ANY THIRD PARTY PRODUCT (EXCEPT AS MAY BE SPECIFIED BY SELLER). With respect to any such Goods during the Warranty Period, Seller shall, at its option, either: (i) repair or replace such Goods (or the defective part) or (ii) credit or refund the Price of such Goods. If Seller so requests, Buyer shall, at Buyer's expense (including but not limited to removal of the Goods and in-coming and out-going freight), return such Goods to Seller. THE REMEDIES SET FORTH IN THIS SECTION 8 SHALL BE THE BUYER'S SOLE AND EXCLUSIVE REMEDY AND SELLER'S ENTIRE LIABILITY FOR ANY BREACH OF THE LIMITED WARRANTY SET FORTH IN THIS SECTION 8. Any action for a breach of warranty must be commenced within one (1) month following expiration of the applicable Warranty Period. Seller hereby disclaims any liability for injuries which may result from the use of the Goods contrary to its instructions.

TERMS & CONDITIONS

- RETURNS:** The Goods may not be returned without prior written authorization by the Seller. Goods returned without prior written authorization will not be accepted. Expenses which result from the return of Goods must be borne by the Buyer. Returned Goods are subject to restocking charges plus outgoing and incoming freight charges. No cash refunds. Credit will be applied to future orders.
- COMPLIANCE WITH LAW:** Buyer shall comply with all applicable laws, regulations and ordinances in carrying out its obligations under this Agreement. Buyer shall maintain in effect all the licenses, permissions, authorizations, consents and permits that it needs to carry out its obligations under this Agreement.
- SAFETY:** Seller disclaims any liability and Buyer agrees to fully indemnify Seller and its employees for all loss and expense, including attorney's fees, relating to any claim or liability or injury resulting from misuse, alteration, or the use of the Goods contrary to written instructions, including but not limited to those included in Seller's catalog. Seller recommends supplementing federal, state and owner safety programs with ANSI B20.1-2012, "Safety Standards for Conveyors and Related Equipment," and ANSI spec z244.1-2003(2008), "Control of Hazardous Energy - Lockout/Tagout and Alternative Methods" **NEVER OPERATE, ADJUST OR INSTALL EQUIPMENT ON A MOVING CONVEYOR.**
- CHANGES AND CANCELLATIONS:** A request to cancel or change a PO must be made in writing at least thirty (30) days before the requested shipment date of the Goods and is subject to Seller's approval. Buyer acknowledges that a change, if accepted by Seller, may affect the price and the delivery of the Goods. In the event of a cancellation or termination, Customer shall, as a condition of such cancellation or termination, be obligated to pay Seller's reasonable costs and expenses incurred or committed to prior to the date of such cancellation or termination plus a reasonable allowance for Seller's lost profits with respect to the Goods. Buyer agrees to pay such costs and expenses promptly following receipt of Seller's invoice therefore, which shall be submitted to Buyer as soon as practicable after such termination or cancellation.
- MISCELLANEOUS:** Seller shall not be liable or responsible to Buyer, or be deemed to have defaulted or breached this Agreement, for any failure or delay in performing any term of this Agreement when and to the extent such failure or delay is caused by or results from circumstances beyond the reasonable control of Seller including, without limitation, acts of God, flood, fire or earthquake. Buyer shall not assign any of its rights or delegate any of its obligations under this Agreement without the prior written consent of Seller. The relationship between the parties is that of independent contractors. Nothing contained in this Agreement shall be construed as creating any agency, partnership, joint venture or other form of joint enterprise, employment or fiduciary relationship between the parties and neither party shall have authority to contract for or bind the other party in any manner whatsoever. This Agreement is for the sole benefit of the parties hereto and their respective successors and permitted assigns and nothing herein, express or implied, is intended to or shall confer upon any other person or entity any legal or equitable right, benefit or remedy of any nature whatsoever under or by reason of these Terms. All matters arising out of or relating to this Agreement are to be governed by and construed in accordance with the internal laws of the State of Iowa without giving effect to any choice or conflict of law provision or rule (whether of the State of Iowa or any other jurisdiction) that would cause the application of the laws of any jurisdiction other than those of the State of Iowa. Any legal suit, action or proceeding arising out of or relating to this Agreement shall be instituted in the federal courts of the United States of America or the courts of the State of Iowa in each case located in the City of Des Moines and County of Polk, and each party irrevocably submits to the exclusive jurisdiction of such courts in any such suit, action or proceeding. All notices, requests, consents, claims, demands, waivers and other communications hereunder (each, a "**Notice**") shall be in writing and addressed to the parties at the addresses set forth on the face of the PO or to such other address that may be designated by the receiving party in writing. All Notices shall be delivered by personal delivery, nationally recognized overnight courier (with all fees pre-paid), facsimile (with confirmation of transmission) or certified or registered mail (in each case, return receipt requested, postage prepaid). Except as otherwise provided in this Agreement, a Notice is effective only (a) upon receipt of the receiving party, and (b) if the party giving the Notice has complied with the requirements of this Section. If any term or provision of this Agreement is invalid, illegal or unenforceable in any jurisdiction, such invalidity, illegality or unenforceability shall not affect any other term or provision of this Agreement or invalidate or render unenforceable such term or provision in any other jurisdiction. Provisions of these Terms which by their nature should apply beyond their terms will remain in force after any termination. The Agreement embodies the entire understanding between the parties with respect to the subject matter hereof and supersedes any prior agreement or understanding between the parties with respect to such matters. In the event that Seller hires an attorney to assert any of its rights or defenses in connection herewith or to collect amounts due, Buyer agrees to be responsible for all of Seller's legal fees and expenses as well as costs of collection.



PPI[®]

WWW.PPI-GLOBAL.COM | SALES@PPI-GLOBAL.COM

Product shown are for illustrative purposes only and may display optional accessories or components. Please contact your sales representative for more information on product specifications. PPI respectively reserves the right to make changes in engineering, design and specifications; add improvements; or discontinue manufacturing at any time without notice obligation. PPI and its respective logos are trademarks of Precision, Inc. in the US and or other countries.