

# RIGHT ANGLE SHAFT MOUNTED DRIVE ASSEMBLY DATA SHEET (2 MOTOR)

FORM: OHL\_RGHTANG2  
PAGE 1  
REV. 4, EC018-913  
12/26/18

**NOTES:**

- 1) DATA NOT NEEDED IF USING FLEXIBLE LOW SPEED COUPLINGS.
- 2) RIGID COUPLING MAY NOT BE PRESENT.
- 3) IF MORE THEN 1 DRIVE PULLEY EXISTS ON THE CONVEYOR, PROVIDE SEPARATE SHEET FOR EACH PULLEY.
- 4) IS THIS A TRIPPER CONVEYOR? ( Y / N )
- 5) FILL OUT EITHER TYPE A, TYPE B, OR TYPE C SECTION DEPENDING ON ORIENTATION

T1: \_\_\_\_\_  
T2: \_\_\_\_\_  
MOTOR HP: \_\_\_\_\_  
BELT SPEED: \_\_\_\_\_

**TYPE A:**

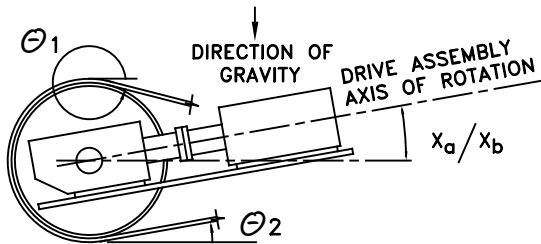
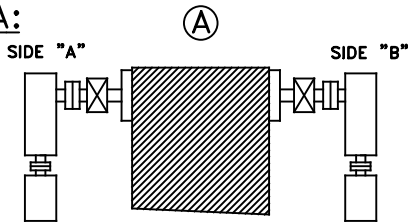

CIRCLE BELT DIRECTION

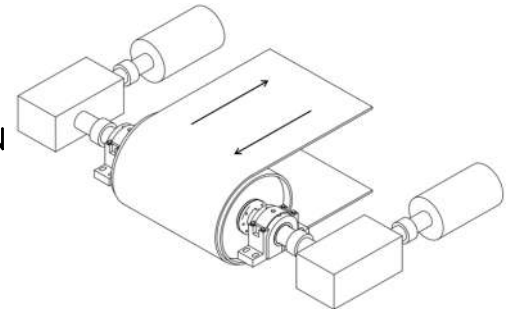

BELT ANGLE COMING OFF PULLEY IN CW DIRECTION ( $\theta_1$ ): \_\_\_\_\_  
 BELT ANGLE COMING OFF PULLEY IN CCW DIRECTION( $\theta_2$ ): \_\_\_\_\_  
 DRIVE ASSEMBLY ANGLE ( $x_a$ ): \_\_\_\_\_  
 DRIVE ASSEMBLY ANGLE ( $x_b$ ): \_\_\_\_\_

**TYPE B:**

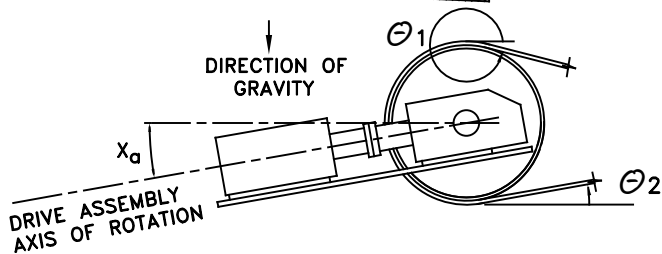
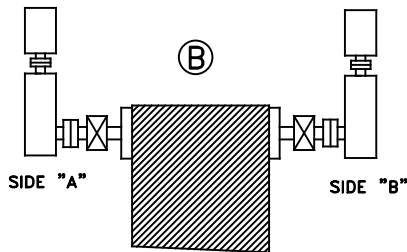

CIRCLE BELT DIRECTION

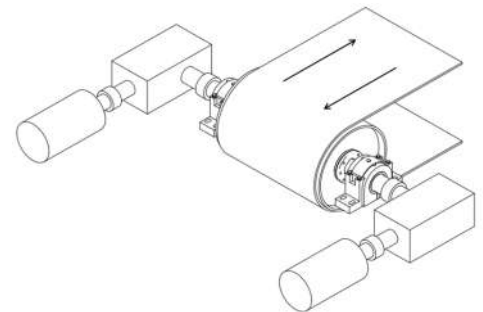

BELT ANGLE COMING OFF PULLEY IN CW DIRECTION ( $\theta_1$ ): \_\_\_\_\_  
 BELT ANGLE COMING OFF PULLEY IN CCW DIRECTION( $\theta_2$ ): \_\_\_\_\_  
 DRIVE ASSEMBLY ANGLE ( $x_a$ ): \_\_\_\_\_  
 DRIVE ASSEMBLY ANGLE ( $x_b$ ): \_\_\_\_\_

**TYPE C:**

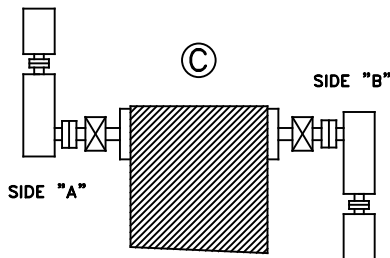

CIRCLE BELT DIRECTION

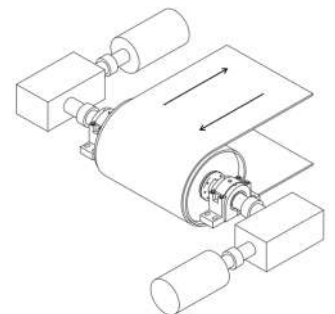

BELT ANGLE COMING OFF PULLEY IN CW DIRECTION ( $\theta_1$ ): \_\_\_\_\_  
 BELT ANGLE COMING OFF PULLEY IN CCW DIRECTION( $\theta_2$ ): \_\_\_\_\_  
 DRIVE ASSEMBLY ANGLE ( $x_a$ ): \_\_\_\_\_  
 DRIVE ASSEMBLY ANGLE ( $x_b$ ): \_\_\_\_\_



# RIGHT ANGLE SHAFT MOUNTED DRIVE ASSEMBLY DATA SHEET (2 MOTOR)

FORM: OHL\_RGHTANG2  
PAGE 2  
REV. 4, EC018-913  
12/26/18

## DRIVE ASSEMBLY DATA

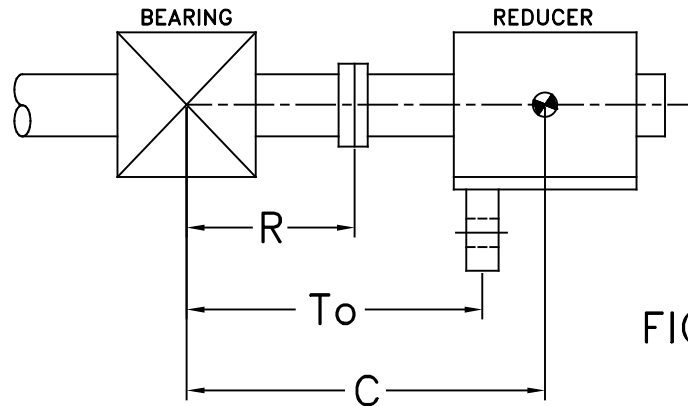

FIG. 1

**FIG. 1**

REDUCER/BEARING CENTER DISTANCE (C): .....	_____
TORQUE ARM/BEARING CENTER DISTANCE (To): .....	_____
RIGID COUPLING/BEARING CENTER DISTANCE (R): .....	_____
RIGID COUPLING WEIGHT: .....	_____

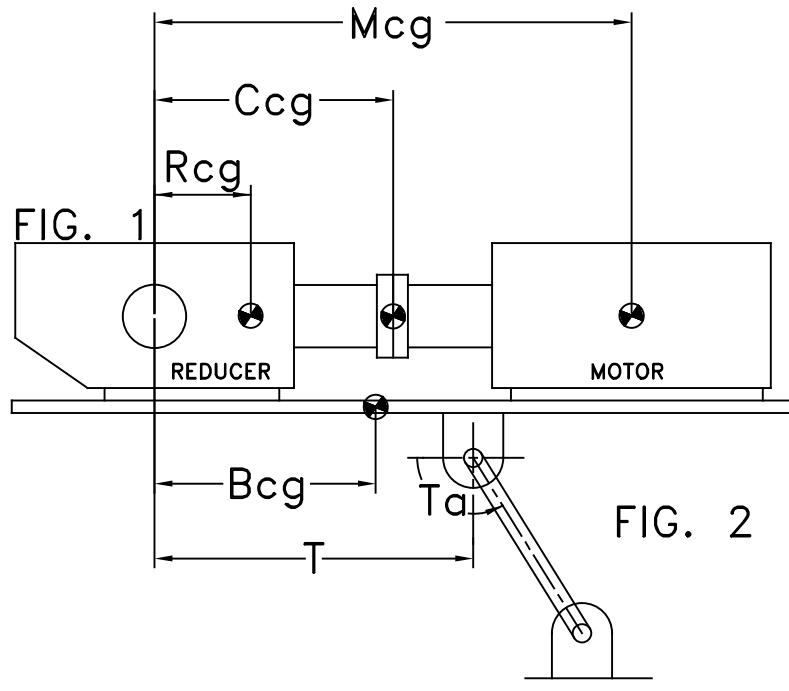

FIG. 2

**FIG. 2**

TORQUE ARM DISTANCE (T): .....	_____
TORQUE ARM ANGLE ( $T_a$ ): .....	_____
REDUCER CENTER OF GRAVITY ( $R_{cg}$ ): .....	_____
REDUCER WEIGHT INCLUDING OIL: .....	_____
HIGH SPEED COUPLING CENTER OF GRAVITY ( $C_{cg}$ ): .....	_____
HIGH SPEED COUPLING WEIGHT: .....	_____
MOTOR CENTER OF GRAVITY ( $M_{cg}$ ): .....	_____
MOTOR WEIGHT: .....	_____
BASE CENTER OF GRAVITY ( $B_{cg}$ ): .....	_____
BASE WEIGHT: .....	_____



\* PPI WILL NOT BE RESPONSIBLE FOR ISSUES RELATED TO OVERHUNG LOADS.