

CENTER MOUNT WING ASSEMBLY DATA SHEET

Wing Type: Standard Duty, Mine Duty, Quarry Duty, Herringbone, or ContinuWing

Pulley Diameter (D) _____

Face Width (FW) _____

Bearing Centers (BC) _____

Overall Shaft Length (OAL) _____

Shaft Drill and Taps _____

Shaft Dia. @ Bushing (d1) _____

Bushing Type and Size _____

Shaft Dia. @ Bearing (d2) _____

Bearing Type and Size _____

Shaft Journal Length (J1) _____

Shaft Journal Length (J2) _____

Right Hand Extension (RHE) _____

Left Hand Extension (LHE) _____

Lagging Type _____

Lagging Thickness _____

Estimated Belt Wrap _____

COMPANY NAME _____

LOCATION _____

CONTACT NAME _____

PHONE _____

EMAIL _____

Identify type of wing needed

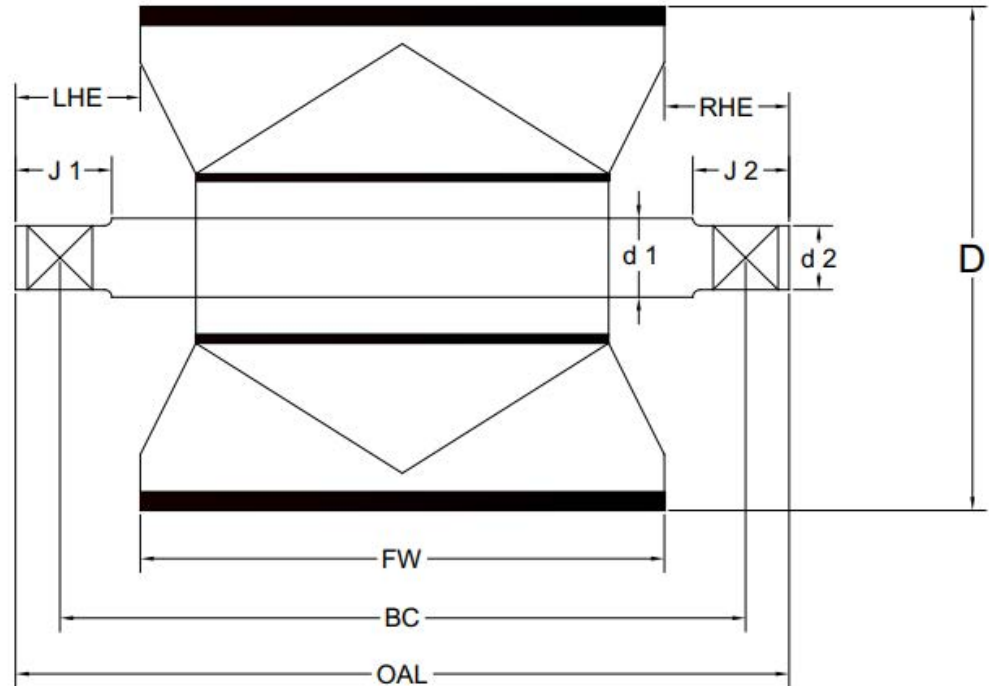

NOTES
