

READ THESE INSTRUCTIONS CAREFULLY BEFORE STARTING INSTALLATION



OPERATION & MAINTENANCE

SMART ROLL & SMART MONITOR



TABLE OF CONTENTS

1. Smart Roll Selection Guide	3
Selecting how many pulses per revolution for the Smart Roll	3
Selecting the Smart Roll Mounting Option and Location	3
Selecting which Smart Monitor to use.....	3
2. Installing and Mounting the Smart Roll	4
Clean Side Return Mounting Instructions	4
Setting up the pivot/hinge	4
Test Fit the Mounting Assembly	5
Final Installation of the Mounting Assembly	5
Pivot / Hinge Option 1: Welding pivot rod to conveyor frame.....	6
Pivot / Hinge Option 2: Use of mounting brackets.....	6
Clean Side Return Smart Roll Diagram & Parts List	7
3. Wiring the Smart Roll.....	8
4. Wiring the Smart Monitor	9
5. Smart Monitor Set-up	12
Trip Point Set-up	12
Ramp-up Timer Set-up	12
Testing Procedure	12
Adjust Ramp-up Timer after Smart Monitor is Installed and Wired into Control Circuit	12
6. Using a PLC.....	13
What is a Pulse?.....	13
What if the pulses are too fast for my electronics?.....	13
Converting pulses to belt speed?.....	13
7. Frequently Asked Questions:	14
Appendix.....	16
A1. Universal Mount Smart Roll	16
Universal Mount Smart Roll Mounting Instructions:	16
Universal Mount Smart Roll Wiring:	16
Universal Mount Smart Roll Diagram & Parts List:	17
A2. Troughing Smart Roll	18
Troughing Smart Roll Mounting Instructions:.....	18
Troughing Smart Roll Wiring:.....	18
Troughing Smart Roll Diagram and Parts List:	19
A3. Return Smart Roll	20
Return Smart Roll Mounting Instructions:	20
Return Smart Roll Wiring:	20
Return Smart Roll Diagram & Parts List:	21
A4. Smart Roll Sensor Wiring Diagrams and Specifications.....	22
A5. Additional Smart Monitors	23
Part number 37545 Smart Monitor 120VAC 4-20mA output	23
Part number 47268 Smart Monitor 9-36 VDC	25
Part number 47269 Smart Monitor 220VAC 4-20mA output	27
A6. Part Numbers.....	29
Smart Monitor Part Numbers	29
Clean Side Return Smart Roll Part Numbers	29
Universal Mount Smart Roll Part Numbers.....	29
Troughing Equal Smart Roll Part Numbers	30
Flat Return Smart Roll Part Numbers.....	31

IMPORTANT – SAFETY INSTRUCTIONS

The Smart Roll needs to be used with a Smart Monitor, PLC, or similar device that can monitor the pulses and select a desired output. Read the complete manual and understand all wiring, pulse selection, and mounting instructions prior to installation. Refer to Section 7: “Frequently Asked Questions” in this manual. If necessary, contact a PPI Applications Engineer.

The Smart Roll and Smart Monitor should be installed by trained personnel using appropriate safety practices per the National Electric Code, including electrical disconnect and lockout practices reference ANSI Z244.1. This device is not intended for use in hazardous areas as defined by the NEC articles 500-504. Intrinsically Safe Smart Rolls and Smart Monitors are not presently available. Follow all procedures for power disconnect, lockout-tagout, mechanical blocking, etc. to ensure safety.

1. SMART ROLL SELECTION GUIDE

SELECTING HOW MANY PULSES PER REVOLUTION FOR THE SMART ROLL

The PPI Smart Roll is a preset sensor switch. As the roll rotates, an electrical circuit is opened and closed to create pulses. It is available in options of 1, 2, or 6 pulses per revolution. The most commonly used is the 2 pulse option. Belt speed, roll diameter, and electronics capabilities are selection considerations. Using the lowest number of pulses per revolution will maximize the time duration of each pulse. The Clean Side Return SAD5CSRSB-2PL4 is the most versatile and most commonly used Smart Roll. Table 1.1 is based on using a Smart Monitor and the Clean Side Return Smart Roll using a 5 inch diameter roll. The actual speed limitations may differ from these limits depending on the roll diameter and electronics.

# PULSES	SPEED (FPM) MIN	SPEED (FPM) MAX	APPLICATION
6	5	700	Feeders/Metering
1-2	20	1000	Normal

TABLE 1.1 – Smart Roll Speed Limitations

SELECTING THE SMART ROLL MOUNTING OPTION AND LOCATION

The Smart Roll is available in 4 mounting options, and can fit most locations on a conveyor.

1. Clean Side Return (CSR) – Preferred
2. Universal Mount – An 11.125” long roll in a mounting bracket with two slots for mounting.
3. Return Roll positions in CEMA C and D sizes. Belt widths from 24-60 inches.
4. Troughing Idler (wing roll only) positions in CEMA C and D sizes. Belt widths from 24-60 inches.

In order for the Smart Roll to provide reliable feedback follow these guidelines:

- The roll must maintain belt contact at all times. Areas with high vibration should be avoided.
- Avoid areas where material can build up on the roll. This can increase the roll diameter and cause errors.
- Select an area and location where the Smart Roll will be best protected from abuse.
- PPI typically recommends the Clean Side Return (CSR) mounting option.
- The next best option is typically the Universal Mount.
- Mounting the Smart Roll in a troughing frame or return position should be considered as a last option.
- The CSR is the most commonly used Smart Roll. This Operation and Maintenance Manual uses this model when explaining the installation and wiring.

SELECTING WHICH SMART MONITOR TO USE

Several models of the Smart Monitor are available. The most commonly used is part number 37543 Smart Monitor 120VAC. This Operation and Maintenance Manual uses this model when explaining the installation and wiring.

- 37543 Smart Monitor 120VAC; Relay Contacts
- 37545 Smart Monitor 120VAC 4-20mA output
- 47268 Smart Monitor 9-36 VDC; Relay Contacts
- 47269 Smart Monitor 220VAC 4-20mA output

Attention must be given to the location of the Smart Roll so that it is always in contact with the belt. Failure to mount properly may void warranty and could cause damage to conveyor belt and other components.

2. INSTALLING AND MOUNTING THE SMART ROLL

NOTE: Care must be taken to avoid scraped, pinched, or crushed wiring. Wires that are scraped, pinched, or crushed during shipping, handling or installation will void the warranty.

Installing the Clean Side Return (CSR) Smart Roll is shown to the right. This is the most commonly used Smart Roll. For mounting the Universal, Trougher or Return Smart Rolls see the appendix.

CLEAN SIDE RETURN MOUNTING INSTRUCTIONS

Setting up the pivot/hinge

Typically, the CSR is mounted on the clean side of the belts return run using a $\frac{3}{4}$ inch diameter rod as a pivot or hinge. Figure 2.1 shows a typical installation for a Clean Side Return Smart Roll on the clean side of the return run of the belt. Care must be taken to select a location allowing free movement of the CSR hinge, see Figure 2.2.

Mounting the CSR in locations restricting free movement of the roll and/or mounting arm may cause premature failure and void the warranty. *CSR should not be used on a reversing belt.* The angle from the belt to the CSR mounting arm should not exceed 45 degrees as shown in Figure 2.2. Proper orientation with belt travel direction, as shown, is critical. Severe roll and/or belt damage may occur if mounted incorrectly.

Two options are shown for mounting the CSR Smart Roll.

Option 1 is welding the pivot shaft to the conveyor frame work and **Option 2** is using mounting brackets bolted to the frame work. Diagrams for the pivot/hinge options are shown at the end of this section.

Option 1:

At the conveyor mounting location, measure the distance between the conveyor framework where the $\frac{3}{4}$ inch diameter shaft will be attached. Cut the shaft to length, removing burrs, and all sharp edges.

Option 2:

At the conveyor mounting location, measure the distance between the conveyor framework where the holes will be located for the mounting brackets. This measurement will determine which mounting bracket hinge option to use.

Options 1 & 2:

Insert the $\frac{3}{4}$ inch diameter shaft through the CSR hinge point. Center the shaft with the hinge point, and install one retaining collar on each end of the shaft as shown in Figure 2.3. Turn shaft collars so set screws are aligned and lightly tighten the set screws.



FIGURE 2.1: Clean Side Return roll in a typical installation. Optional CSR mounting hardware shown. Conduit and wire tire not included.

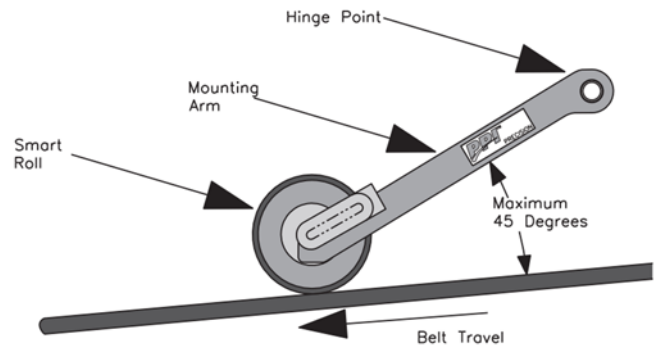

FIGURE 2.2: CSR Mounting



FIGURE 2.3: CSR Mounting Accessories test fit in CSR hinge point.
CSR Mounting Accessories sold separately.

Test Fit the Mounting Assembly

Option 1:

Test fit the CSR and Mounting assembly in the conveyor framework before doing the final installation. Place the CSR and Mounting assembly in conveyor framework as shown in Figure 2.4. *Be sure the travel direction and path of the wire and/or conduit is correct, and that the set screws are accessible. The Smart Roll should be in the center of the belt.* Check to make sure the roll is free to rotate and mounting arm is free to pivot through its full range of motion. If there are any obstructions, move the CSR and Mounting assembly out of the way and make the necessary adjustments.

Option 2:

Install both mounting brackets to the conveyor framework. One bracket will be installed on each side of the belt with slots facing upward and toward the center of the belt. Holes might be needed in the structure for attaching the brackets.

Option 1 & 2:

Move both collars to within 1/8 inch of CSR hinge and tighten securely.

Final Installation of the Mounting Assembly

Option 1:

Prepare the site for welding the 3/4 inch diameter shaft to the conveyor framework by providing adequate protection for the belt and other components. Welding to be performed by qualified individuals trained to AWS, or equivalent. *PPI is not capable of being aware of all site specific and industry welding requirements for an application, and cannot be held liable for non-compliant installations.* Proper weld ground location is critical to prevent damage to bearings and sensor inside the Smart Roll. These components will not tolerate welding current through them and will be permanently damaged. Improper ground placement will void warranty.

Figure 2.5 shows a typical welding set-up. Weld ground is placed in a location keeping the flow of current away from the roll. Keep the belt splice at least six inches away from the Smart Roll to further reduce the chance of welding current damage.

When welding is completed remove welding protection, clamps, welding ground, and any other objects used in installation. Clean weld area and provide paint or other protective coating per accepted site practice.

Option 2:

With the 3/4 inch diameter rod installed in the CSR hinge, slide the slots at the ends of the rod into the slots on the brackets. On each end of the shaft install the teardrop shaped end clip over the end of the shaft. Then install the screw into the hole in the end clip and bracket. This is a self-threading screw; take care not to strip the threads on the screw or the hole in the bracket.



FIGURE 2.4: Test fit of CSR and Mounting Accessory assembly in conveyor framework, typical both sides.



FIGURE 2.5: Permanent attachment of 3/4 inch shaft to framework. Component protection for welding has been removed for clarity.

PIVOT / HINGE OPTION 1: WELDING PIVOT ROD TO CONVEYOR FRAME

PART # 42971 – COMPONENTS 4 FEET LONG – CARBON STEEL			
ITEM	QTY	DESCRIPTION	PART #
1	1	3/4" diameter x 4' long rod	43180
2	2	Shaft Collar	SC0012

PART# 42971S4 – COMPONENTS 4 FEET LONG – STAINLESS STEEL			
ITEM	QTY	DESCRIPTION	PART #
1	1	3/4" diameter x 4' long rod	43180S4
2	2	Shaft Collar - Stainless Steel	SC0012S4

PART# 42972 – COMPONENTS 7 FEET LONG – CARBON STEEL			
ITEM	QTY	DESCRIPTION	PART #
1	1	3/4" diameter x 7' long rod	43181
2	2	Shaft Collar	SC0012

PART# 42972S4 – COMPONENTS 7 FEET LONG – STAINLESS STEEL			
ITEM	QTY	DESCRIPTION	PART #
1	1	3/4" diameter x 7' long rod	43181S4
2	2	Shaft Collar	SC0012S4

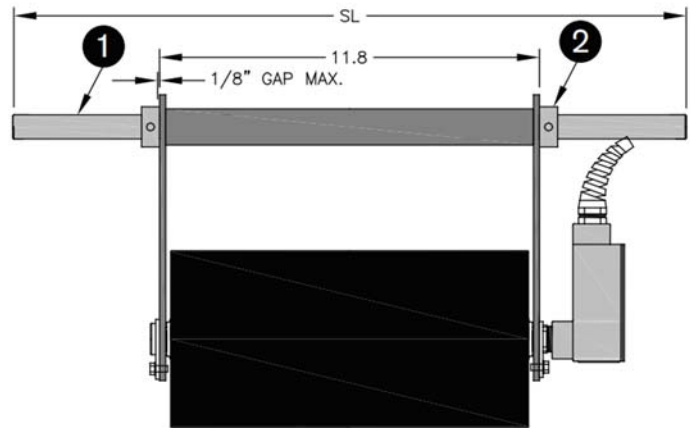

PIVOT / HINGE OPTION 2: USE OF MOUNTING BRACKETS

ASSEMBLIES WITH RODS – CARBON STEEL				
ASSEMBLY PART #	SHAFT PART #	SL	HC	BELT WIDTH
CSR-24	43521	28.625	33.0	24
CSR-30	43522	34.625	39.0	30
CSR-36	43523	40.625	45.0	36
CSR-42	43524	46.625	51.0	42
CSR-48	43525	52.625	57.0	48
CSR-54	43526	58.625	63.0	54
CSR-60	43527	64.625	69.0	60
CSR-66	43528	70.625	75.0	66
CSR-72	43529	76.625	81.0	72
CSR-78	43670	82.625	87.0	78
CSR-84	43671	88.625	93.0	84
CSR-90	43672	94.625	99.0	90
CSR-96	43673	100.625	105.0	96

COMPONENTS – CARBON STEEL RODS			
ITEM	QTY	DESCRIPTION	PART #
1	1	3/4" diameter rod	TABLE
2	2	Shaft Collar	SC0012
3	2	1-1/2" End Stand	15001
4	2	C End Clip	31790
5	2	#12-3/8" Self Tapping Screw	31880

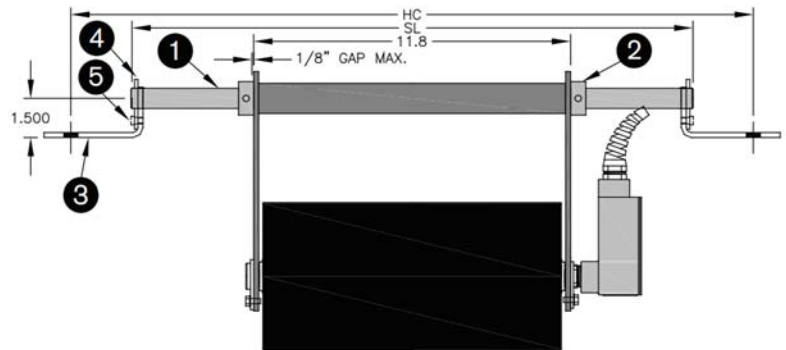

ASSEMBLIES WITH RODS – STAINLESS STEEL				
ASSEMBLY PART #	SHAFT PART #	SL	HC	BELT WIDTH
CSR-24S4	43521S4	28.625	33.0	24
CSR-30S4	43522S4	34.625	39.0	30
CSR-36S4	43523S4	40.625	45.0	36
CSR-42S4	43524S4	46.625	51.0	42
CSR-48S4	43525S4	52.625	57.0	48
CSR-54S4	43526S4	58.625	63.0	54
CSR-60S4	43527S4	64.625	69.0	60
CSR-66S4	43528S4	70.625	75.0	66
CSR-72S4	43529S4	76.625	81.0	72
CSR-78S4	43670S4	82.625	87.0	78
CSR-84S4	43671S4	88.625	93.0	84
CSR-90S4	43672S4	94.625	99.0	90
CSR-96S4	43673S4	100.625	105.0	96

COMPONENTS – STAINLESS STEEL RODS			
ITEM	QTY	DESCRIPTION	PART #
1	1	3/4" diameter rod	TABLE
2	2	Shaft Collar	SC0012S4
3	2	1-1/2" End Stand	15001
4	2	C End Clip	31790
5	2	#12 x 3/8 Self Tapping Screw	31880

CLEAN SIDE RETURN SMART ROLL DIAGRAM & PARTS LIST

ASSEMBLY COMPONENTS			
ITEM	QTY	DESCRIPTION	PART #
1	1	Smart Roll	TABLE
2	1	CSR Bracket	40820
3	1	D End Clip	47117
4	2	#12-3/8" Self Tapping Screw	31880
5	1	B End Clip	31800
6	1	Hex Bushing	34461
7	1	90° Elbow Conduit Access Port	34452
8	1	Strain Relief Fitting	40824

CSR SMART ROLLS		
ROLL Ø	ASSEMBLY PART #	ROLL ONLY PART #
5.5	SAD5CSRSB – 1PL4	SAD5TE30SB – 1PL4
5.5	SAD5CSRSB – 2PL4	SAD5TE30SB – 2PL4
5.5	SAD5CSRSB – 6PL4	SAD5TE30SB – 6PL4
6.5	SAD6CSRSB – 1PL4	SAD6TE30SB – 1PL4
6.5	SAD6CSRSB – 2PL4	SAD6TE30SB – 2PL4
6.5	SAD6CSRSB – 6PL4	SAD6TE30SB – 6PL4

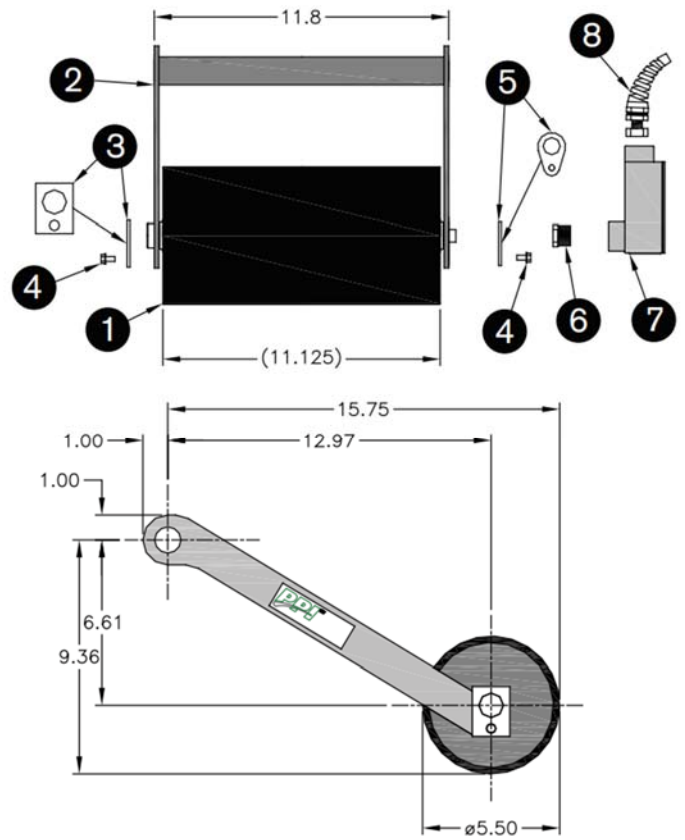

3. WIRING THE SMART ROLL

1. Disconnect and lockout power before starting wiring procedure.

The CSR Smart Roll is provided with a ½ inch 90° elbow conduit access port and a strain relief. The Smart Roll cable is 2 wire, 22 AWG, PVC jacket, PVC insulation, and 6 feet in length. No set-up is required to the sensor inside the Smart Roll. It is factory set and maintenance free.

DO NOT apply voltage directly across the wires of the Smart Roll Sensor, permanent damage may result. The Smart Roll is designed to be used with a Smart Monitor, PLC, or similar device.

DO NOT use an incandescent light bulb as a load. An overload will occur due to extremely high cold current.

DO NOT operate without a load. A dead short will result which may cause irreparable damage.

DO NOT directly operate a motor with the sensor. Always use a relay or other appropriate device.

2. At this point a 2 wire cable needs to be routed from the control box housing the Smart Monitor to the Smart Roll. It is recommended to use minimum of 22 AWG shielded cable. Shielded cable eliminates electromagnetic interference (EMI). *It is advisable to route the wires/conduit for the Smart Roll away from electrical power conduit as the electrical power may cause electromagnetic interference (EMI) in the signal from the Smart Roll. If EMI is present the signal from the Smart Roll may not make it to the Smart Monitor or PLC. This will result in the Smart Monitor or PLC getting faulty readings.*

Conduit from the control box to the Smart Roll offers more protection to the cable. Any nick, gouge, or cut in the cable wiring could prevent the sensor signal from reaching the Smart Monitor.

If flexible conduit is used then the strain relief is not needed and can be removed. PPI recommends the wires or flexible conduit be routed along the side of the CSR bracket and towards the hinge point. This will allow for free motion of the hinge. Be sure the wires or conduit will not hinder the pivoting of the smart roll.

PPI is not capable of being aware of all site and industry electrical requirements for an application, and cannot be held liable for non-compliant installations. The product has been designed to be capable of meeting many requirements, and a qualified individual should review the connection plan prior to installation. Connection of conduit to 90° elbow conduit access port does not meet intrinsically safe requirements.

DO NOT PULL THE WIRES CONNECTED TO THE SMART ROLL. Pulling wire from inside the roll will cause damage and void warranty. Be sure to protect the wire near elbow threads and all corners, as this may damage the wire/insulation.

3. Remove the cover from the 90° elbow conduit access port and route the Smart Roll wires and the wires from the control box through the conduit opening in the 90° elbow access port and out the rectangular opening.
4. Attach the conduit to the 90° elbow access port.
5. Attach the Smart Roll wires to the wires from the control box. Cut wires to proper length to fit in junction box. DO NOT apply power to the sensor at this time. The Smart Monitor or PLC provides the power for the Smart Roll. To avoid damage, verify the circuit meets the sensor specifications shown in Appendix A4 prior to applying power.
6. Reinstall junction box lid and tighten screws to secure.

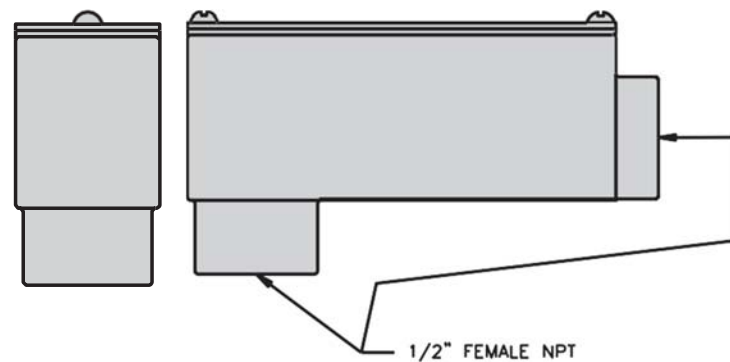

FIGURE 3.1: 90° Elbow Conduit Access Port.

4. WIRING THE SMART MONITOR

The Smart Monitor provides an under speed switch by monitoring 6-3,000 pulses per minute (PPM) and has a user-programmable 0-30 second ramp-up timer. The Smart Monitor is designed to be located in an electrical panel or OEM control box. A removable plate allows for mounting to a DIN rail. The digital display shows the current PPM in real time. This eliminates setting “guesswork” by constantly showing the actual PPM being monitored.



The digital display shows “RPM” next to the monitored speed. This can be misleading with a 2 or 6 pulse Smart Roll, as the monitor is actually displaying pulses per minute (PPM).

As with any electrical equipment, the Smart Monitor should be installed by trained personnel using appropriate safety practices per the National Electric Code, including electrical disconnect and lockout practices reference ANSI Z244.1.

This device is not intended for use in hazardous areas as defined by the NEC articles 500-504. Intrinsically Safe Smart Monitors are not presently available.

Several models of the Smart Monitor are available. This section will show wiring for the 120VAC model part number 37543.

Specification – 37543 Smart Monitor 120VAC

- AC Input: 120 VAC 10 W
- Fuse Protected: 1 amp
- Speed Range: 6-3000 pulses per minute
- Relay Contacts: DPDT 5 amp @ 120VAC
- Safety Delay: 1 second
- Response Time: 1 second or less

Additional models of the Smart Monitor are available.

Specifications for these are shown in the appendices:

- Part number 37545 Smart Monitor 120VAC 4-20mA output
- Part number 47268 Smart Monitor 9-36 VDC
- Part number 47269 Smart Monitor 220VAC 4-20mA output

1. Mount the Smart Monitor inside an existing control panel or other suitable protective enclosure. See Figure 4.1 for Smart Monitor mounting dimensions.
2. Disconnect AC power before proceeding with installation.
3. Table 4.2 shows connection details for the terminal strip.
4. Figure 4.3 shows a sample wiring diagram of how the Smart Monitor can be wired into your system. If you are familiar with PPI's older Smart Monitor, see Figure 4.4 comparing the wiring diagrams.

5. Connect Smart Roll wires to terminals 7 and 8. Polarity of the wires is not important.
6. Connect the wiring for the 120 VAC to terminals 15 and 16 to power the Smart Monitor.
7. The Smart Monitor provides the power for the Smart Roll through terminals 7 and 8.
8. Terminals 9 through 14 are customer contacts to be used for system control.
9. Remove lockouts and apply power to the Smart Monitor.

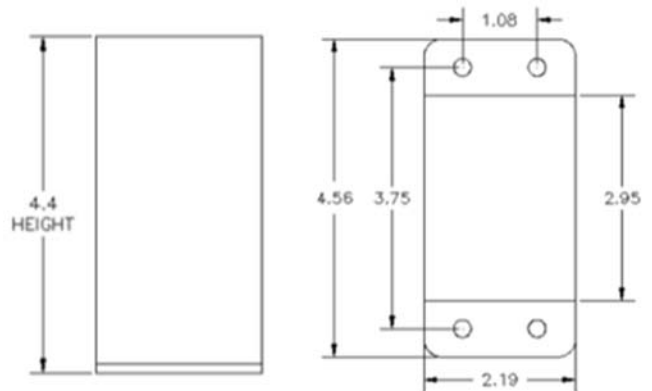
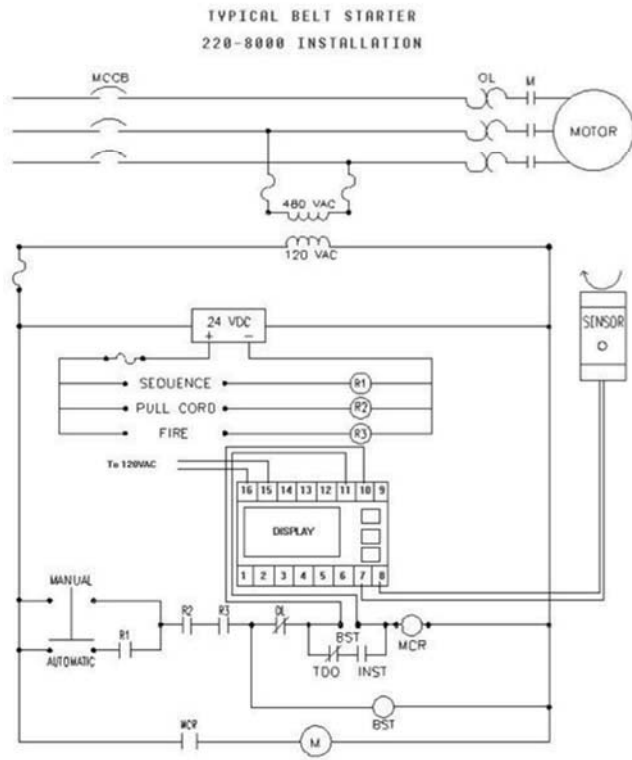

FIGURE 4.1: 37543 Smart Monitor dimensions.

TERMINAL	CONNECTION
FRONT	
1	NO CONNECTION
2	NO CONNECTION
3	NO CONNECTION
4	NO CONNECTION
5	NO CONNECTION
6	NO CONNECTION
7	Sensor Input (+)
8	Sensor Input Common (-)
BACK	
9	N/C (2)
10	Common (2)
11	N/O (2)
12	N/C (1)
13	Common (1)
14	N/O (1)
15	AC Input (N)
16	AC Input (H)

TABLE 4.2: 37543 Smart Monitor terminal connections.

**TYPICAL BELT STARTER
(Ramp-up Timer Disabled (Default))**



**TYPICAL BELT STARTER
(Ramp-up Timer Enabled)**

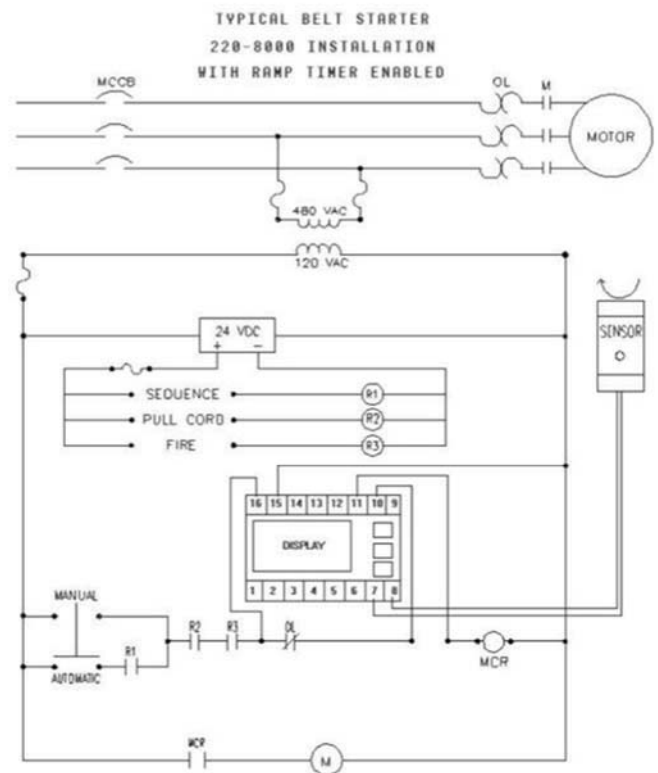

Figure 4.3 Sample Wiring Diagram

INSTALLATION CROSS REFERENCE

Old Socket Mounted Tac Switch

New Plate Mounted Tac Switch



TAC-SWITCH
Critical Speed Switch
MODEL 22-8000

TAC-SWITCH
Digital Speed Switch
MODEL 220-8000

TYPICAL BELT STARTER
22-8000 INSTALLATION

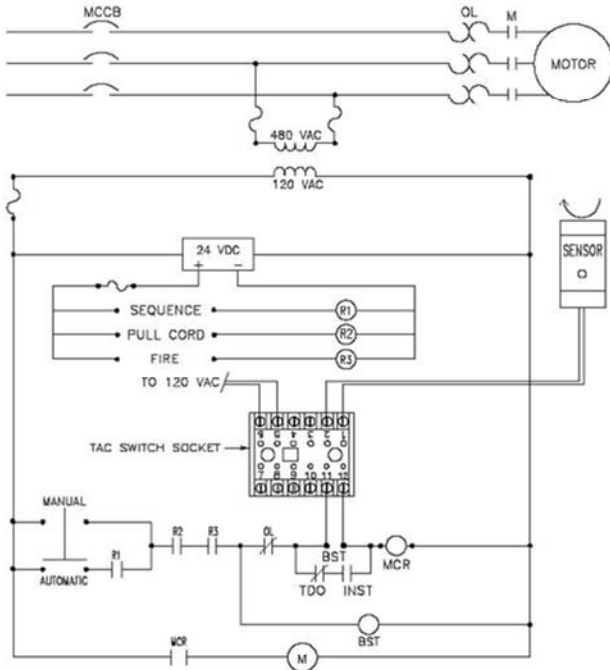

TYPICAL BELT STARTER
220-8000 INSTALLATION

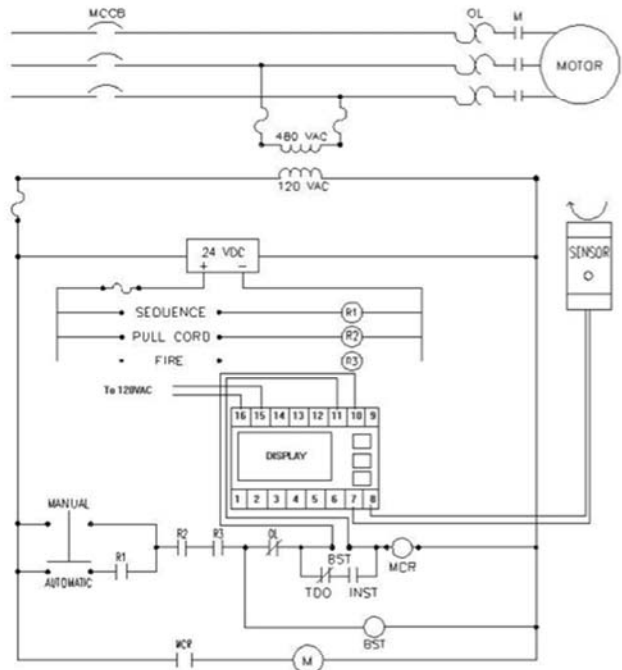

Old Model
22-8000

New Model
220-8000



TERMINAL	CONNECTION	TERMINAL
1	Sensor - Common (-)	8
2	Sensor - Positive (+)	7
4	Earth Ground	8
5	120 VAC (H)	16
6	120VAC (N)	15
11	Relay - Common (2)	10
12	Relay - N/O (2)	11

Note – as connections for the new Tac Switch are located on the top of the unit, you may need to extend your connecting wires. This is perfectly acceptable.

Figure 4 .4: Installation cross reference for old and new Smart Monitors.

TRIP POINT SET-UP

Apply power to the Smart Monitor. If this is the first time powering the unit up, the default trip point is 6 RPM or PPM, the built-in ramp-uptimer is disabled and the relay is off (TRIP: 0006 / RAMP: 0S / REL: OFF). Read through the following instructions before starting the set-up procedure.

1. Momentarily depress the down arrow button once to highlight "TEST."
2. Momentarily depress the down arrow a second time to highlight "TRIP."
3. Momentarily depress the SET button to begin setting unit to the trip speed desired, starting with the 4th digit (the 1000s place). When highlighted, use the up/down arrow buttons to change number as needed. When 4th place is set correctly, momentarily depress the SET button to begin setting the 3rd (100s place) digit. Again, use the up/down arrow buttons to change the number. When set correctly, momentarily depress the SET button to begin setting the 2nd (10s place) digit. Use up/down arrow buttons as before to change the number, and once set, momentarily depress the SET button to begin setting the 1st and final digit. The selection will time out and reset after approximately 15 seconds with no new input.
4. Review your settings for accuracy. If a digit needs to be adjusted, momentarily depress the SET button one or more times to get to the proper digit, then use the up/down arrows to switch number and when satisfied, press and hold the SET button – the RPM setting will highlight and then go back to normal. The SET button can then be released. The RPM setting will be maintained in non-volatile memory until changed by the operator.

RAMP-UP TIMER SET-UP

The default setting for the ramp-up timer is 0 seconds (timer disabled). To set the timer for a 1 to 30 second ramp-up period, follow the procedure below:

1. Momentarily depress the down arrow to highlight "RAMP."
2. Momentarily depress the SET button to highlight the timer in seconds.
3. Use the up/down arrow buttons to increment the timer from 0 seconds up to a max of 30 seconds. The selection will time out and reset after approximately 15 seconds with no new input.

When satisfied, press and hold the SET button – the timer setting will highlight then return to normal.

TESTING PROCEDURE

1. A test function has been provided to allow the operator to de-energize the internal control relay and stop the monitored equipment. To activate a test shutdown,
2. Momentarily depress the down arrow button once to highlight "TEST."
3. Depress and HOLD the SET button for approximately 3 seconds – the control relay will de-energize.
4. Release the SET button. There is a safety delay that will keep the control relay off for 10 seconds after it has de-energized. The relay will automatically re-energize after the delay if RPM above the programmed trip point is detected.

ADJUST RAMP-UP TIMER AFTER SMART MONITOR IS INSTALLED AND WIRED INTO CONTROL CIRCUIT

There may be times when after installation the ramp-up timer is found to be set too short a period of time. This presents a problem because when the equipment being monitored is shut down, there is also no power going through the Smart Monitor. The following procedure should be performed to allow setting of the ramp-up timer on the next equipment start-up cycle:

1. Before starting the monitored equipment, depress and hold the SET button until the equipment start-up sequence has been initiated – the display of the Smart Monitor will be powered on, "RAMP" will be highlighted and the control relay (REL) will be "ON" (energized).
2. Release the SET button then use the up arrow button to increment the ramp-up timer to the desired number of seconds (max of 30).
3. Depress and release the SET button to "write" the new ramp-up timer setting in to the Smart Monitor. The new setting will be used on the next equipment start-up sequence.

The Programmable Logic Controller (PLC) and Smart Roll work together to give the desired output. Typically, the pulses from a Smart Roll are read by a PLC and converted to a speed output. This speed output can then be used by the PLC to create actions, such as shutting down a conveyor due to an under speed condition.

If the roll is rotating too fast or the PLC is not sampling often enough, the output will not work as desired. There are specifications you will need to know about your conveyor setup, PLC, and Smart Roll sensor. These specifications are belt speed, outside diameter including lagging of the Smart Roll, pulses per revolution of the Smart Roll, sampling rate of the PLC and/or the minimum sample duration, and power supplied to the sensor from the PLC.

The Smart Roll sensor has a maximum switching frequency of 20 Hz, or 20 pulses per second. Digital electronic equipment, such as a PLC, takes intermittent sensor readings rather than continuously monitoring the sensor. If the switching of the sensor pulses is faster than the sampling rate of the equipment, errors may occur. Marginal cases may have erroneous speed output from missed pulses, and extreme cases may cause a complete lack of output.

WHAT IS A PULSE?

As the roll rotates, it opens and closes an electrical circuit to create pulses a preset number of times per revolution. One pulse is defined as one complete on/off cycle.

Examples:

6 pulses per revolution the sensor creates 6 on/off cycles, or pulses for each revolution.

2 pulses per revolution the sensor creates 2 on/off cycles, or pulses for each revolution.

1 pulse per revolution the sensor creates 1 on/off cycle, or pulses for each revolution.

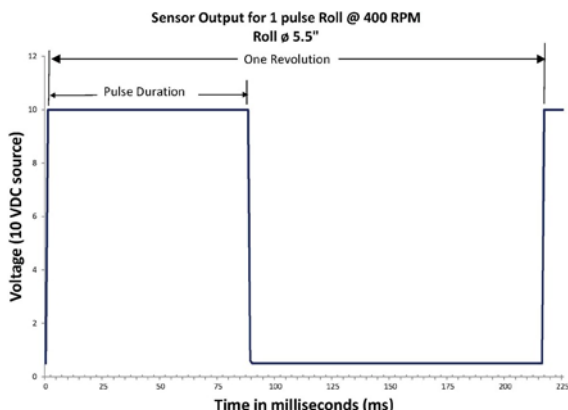

Figure 6.1: Example sensor output for a 1 pulse roll, P/N SAD5CSRSB-1PL4

The 1 and 2 pulse options have fewer pulses and greater pulse duration, i.e. the pulse will have a greater width on the chart. Figures 6.1 and 6.2 show pulses using 400 feet per minute belt speed, Smart Roll part numbers SAD5CSRSB-1PL4, and SAD5CSRSB-2PL4 respectively.

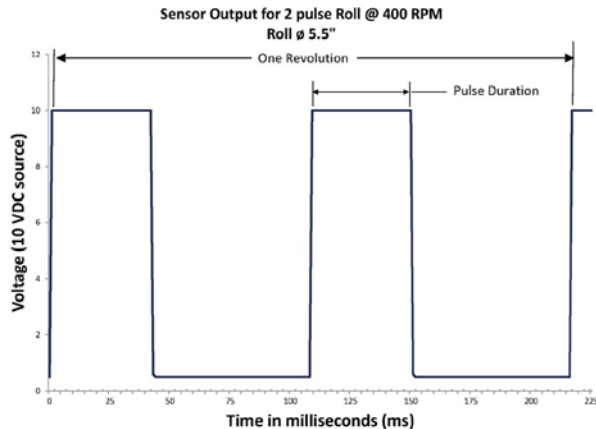

Figure 6.2: Example sensor output for a 2 pulse roll, P/N SAD5CSRSB-2PL4

WHAT IF THE PULSES ARE TOO FAST FOR MY ELECTRONICS?

There are several options in this case.

1. Select a roll with a lower number of pulses per revolution. If you are using a Smart Roll with 6 pulses per revolution, switch to a 2 pulse or 1 pulse per revolution Smart Roll. The PLC will have more time between pulses and longer pulse duration. This is the preferred method.
2. Reprogram the PLC or electronics to a faster sampling rate and/or longer sampling durations.
3. Change to a larger diameter roll. If you are using a 5" diameter Smart Roll without lagging, switch to a roll with ¼" of lagging to make the Smart Roll 5.5" diameter, or switch to a 6" diameter Smart roll with or without lagging.

CONVERTING PULSES TO BELT SPEED?

The following equation can be used to convert Smart Roll pulses to belt speed.

$$fpm = \left(\frac{15.708(count)(D)}{Time(\#pulse)} \right) = \left(\frac{\pi(count)(D)60}{Time(\#pulse)12} \right)$$

D = Roller Outside Diameter including lagging, in inches.
 Count = # of pulses counted per sampling time period.
 Time = Sampling time period in seconds.
 #pulse = # of pulses per revolution of the Smart Roll (1, 2, or 6).
 fpm = belt speed in feet per minute.

7. FREQUENTLY ASKED QUESTIONS

WHAT IS A PPI SMART ROLL?

The PPI Smart Roll is a PPI idler roll with a sensor built inside the roll. All the components inside the roll are aligned, ready to use, and maintenance free. As the roll rotates the sensor opens and closes a circuit to produce on/off pulses. Additional electronics such as the Smart Monitor or PLC are needed to convert these pulses into a usable function.

WHY IS THE CLEAN SIDE RETURN (CSR) PREFERRED?

More versatile: Because the CSR is independent of the belt width it can reduce your spares inventory. Putting Smart Rolls into troughing or return positions can cause increased inventory expenses because each belt width requires a different Smart Roll spare.

Lasts longer: The CSR Smart Roll practically eliminates load on the roll because it does not support the weight of the belt or material.

The CSR is more forgiving in dirty environments. The CSR can be mounted in a protected location. The CSR Mounting bracket is designed to rotate so that if material gets between the roll and belt, it is free to roll over the debris. The use of CSR is not recommended for reversing belts.

WHAT IS A PPI SMART MONITOR?

The PPI Smart Monitor is used to convert the pulses from the Smart Roll into a usable form. Using the Smart Monitor a critical speed is set, when the speed falls below the set point the Smart Monitor will energize a relay. The relays can then be wired into the conveyor controls. The Smart Monitor also has a ramp up timer that can be set from 0 seconds up to 30 seconds.

IS A PPI SMART MONITOR REQUIRED WHEN USING A PPI SMART ROLL?

A Smart Monitor, PLC, or other similar device is required to read the Smart Roll pulses and convert them into a usable form.

CAN A PLC BE USED WITH THE PPI SMART ROLL?

Yes, the Smart Roll uses an inductive proximity sensor capable of handling most situations. It is normally open and can be wired in a 20-250 VAC or 10-300 VDC circuit.

IS IT POSSIBLE TO TEST THE SMART ROLL SENSOR BEFORE IT IS INSTALLED?

Yes, the test equipment must be able to apply power and detect when the circuit is opened and closed. There are several sensor testers on the market; Contrinex, HTM, RS PRO, and others make sensor testers that can test the Smart Roll sensor.

IS IT POSSIBLE TO TEST THE ROLL AFTER IT IS INSTALLED ON THE CONVEYOR?

Yes. Using a sensor tester mentioned above, the Smart Roll must be disconnected from the Smart Monitor or PLC, whichever is being used, before the sensor tester is connected.

WHY DOES PPI NOT RECOMMEND USING A CLEAN SIDE RETURN SMART ROLL WITH REVERSING BELTS?

When the belt and material reverse the Smart Roll could catch and flex the wrong direction, damaging the wiring and Smart Roll.

WHAT DOES PPI RECOMMEND USING WITH A REVERSING BELT?

PPI recommends using a Universal Mount Smart Roll. This mounting option allows the Smart Roll to stay in contact with belt when the belt is moving in either direction.

CAN THE SMART ROLL / SMART MONITOR DETECT BELT DIRECTION?

No, the Smart Roll only produces pulses and the Smart Monitor reads the pulses. The Smart Roll / Smart Monitor can only indicate that the roll is turning, i.e. the belt is moving, but cannot indicate the direction in which the belt is traveling. In addition, the Smart Roll / Smart Monitor cannot be running one direction, stop, and then start running the other direction and continue uninterrupted operation. In this case, when the belt stops the Smart Roll / Smart Monitor will go below the trip point and energize the relay. If this is required, a Smart Roll with a 4-20 mA Smart Monitor (see Appendix A5) in conjunction with a PLC, this functionality could be programmed.

DOES THE SENSOR INSIDE THE SMART ROLL HAVE OVERLOAD PROTECTION?

To minimize possible damage the sensor includes short circuit and overload protection.

HOW IS THE SMART ROLL SENSOR RESET IF THE OVERLOAD PROTECTION HAS BEEN TRIGGERED?

To reset the sensor, power to the sensor must be removed and the roll turned. Turning the roll will move the target away from the sensor to allow it to be reset. Using the 90° elbow conduit access port, disconnect the wires that provide power to the Smart Roll. Rotate the Smart Roll several revolutions and then reconnect. The sensor is now reset and power can be reconnected. PPI recommends determining and correcting the cause of overload or short circuit prior to re-energizing the sensor.

IS THE SMART ROLL AND SMART MONITOR INTRINSICALLY SAFE?

No, Intrinsically Safe Smart Rolls and Smart Monitors are not presently available.

DOES THE SMART ROLL REQUIRE MAINTENANCE?

Maintenance is minimal, check the roll periodically as you would any idler roll for ease of turning and for buildup on the roll. Also make sure that the CSR is free and rolls smoothly on the belt surface. If mounted properly, it should give years of service.

WHY ISN'T MY SMART MONITOR RAMP-UP TIMER DOING ANYTHING WHEN I START MY CONVEYOR?

See the two options for wiring the Smart Monitor in Section 4 "Wiring the Smart Monitor." The ramp-up timer will only keep the relay energized when the Smart Monitor first receives power. When 120 VAC is applied to the power cable, the timer function will energize the control relay. After the time has elapsed the relay will de-energize unless the belt is running above the set speed.

UNIVERSAL MOUNT SMART ROLL MOUNTING INSTRUCTIONS

Attention must be given to the location of the Smart Roll so that it is always in contact with the belt. Failure to mount properly may void warranty and could cause damage to conveyor belt and other components.

NOTE: Care must be taken to avoid scraped, pinched, or crushed wiring. Wires that are scraped, pinched, or crushed during shipping, handling or installation will void the warranty.

1. Identify the Smart Roll as a Universal Mount Smart Roll and select the mounting site on the conveyor.
2. Determine which side of the conveyor is desirable for running the conduit/wires for the Smart Roll. *It is advisable to route the wires/ conduit for the Smart Roll away from electrical power conduit as the electrical power may cause electromagnetic interference (EMI) in the signal from the Smart Roll. If EMI is present the signal from the Smart Roll may not make it to the Smart Monitor or PLC. This will result in the Smart Monitor or PLC getting faulty readings.*
3. Unscrew the self-tapping screws on the end clips that hold the Smart Roll in the Universal Mount frame.
4. Remove the Smart Roll from the frame and set it and the end clips and screws aside for later assembly.
5. The Universal Mount frame has two 0.56" x 1" slots for attaching the frame to the customer designed mounting location. Fasten the Universal Mount frame in place using two ½" diameter bolts, lock washers, and nuts (not provided with the Universal Mount Smart Roll). This mounting location must keep the Smart Roll in constant contact with the conveyor belt to provide accurate information.
6. Place the Smart Roll in the Universal Mount frame and lock in place with the end clips and screws.

UNIVERSAL MOUNT SMART ROLL WIRING

1. Disconnect and lockout power before starting wiring procedure

The Smart Roll is provided with a ½ inch 90° elbow conduit access port. The Smart Roll cable is 2 wire, 22 AWG, PVC jacket, PVC insulation, and 6 feet in length. No set-up is required to the sensor inside the Smart Roll. It is factory set and maintenance free.

DO NOT apply voltage directly across the wires of the Smart Roll Sensor, permanent damage may result. The Smart Roll is designed to be used with a Smart Monitor, PLC or similar device.

DO NOT use an incandescent light bulb as a load. An overload will occur due to extremely high cold current.

DO NOT operate without a load. A dead short will result which may cause irreparable damage.

DO NOT directly operate a motor with the sensor. Always use a relay or other appropriate device.

2. At this point a 2 wire cable needs to be routed from the control box housing the Smart Monitor to the Smart Roll. It is recommended to use minimum of 22 AWG shielded cable. Shielded cable eliminates electromagnetic interference (EMI). It is advisable to route the wires/conduit for the Smart Roll away from electrical power conduit as the electrical power may cause electromagnetic interference (EMI) in the signal from the Smart Roll. If EMI is present the signal from the Smart Roll may not make it to the Smart Monitor or PLC. This will result in the Smart Monitor or PLC getting faulty readings.

Conduit from the control box to the Smart Roll offers more protection to the cable. Any nick, gouge or cut in the cable wiring could prevent the sensor signal from reaching the Smart Monitor.

PPI is not capable of being aware of all site and industry electrical requirements for an application, and cannot be held liable for non-compliant installations. The product has been designed to be capable of meeting many requirements, and a qualified individual should review the connection plan prior to installation. Connection of conduit to 90° elbow conduit access port does not meet intrinsically safe requirements.

DO NOT PULL THE WIRES CONNECTED TO THE SMART ROLL. Pulling wire from inside the roll will cause damage and void warranty. Be sure to protect the wire near elbow threads and all corners, as this may damage the wire/insulation.

3. Remove the cover from the 90° elbow conduit access port and route the Smart Roll wires and the wires from the control box through the conduit opening in the 90° elbow access port and out the rectangular opening.
4. Attach the conduit to the 90° elbow access port.
5. Attach the Smart Roll wires to the wires from the control box. Cut wires to proper length to fit in junction box. DO NOT apply power to the sensor at this time. The Smart Monitor or PLC provides the power for the Smart Roll. To avoid damage, verify the circuit meets the sensor specifications shown in Appendix A4 prior to applying power:
6. Reinstall junction box lid and tighten screws to secure.
7. Proceed to Section 4: "Wiring the Smart Monitor."

UNIVERSAL MOUNT SMART ROLL DIAGRAM & PARTS LIST:

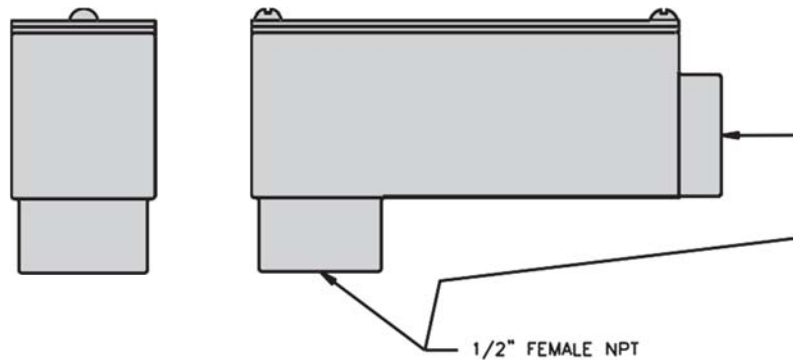
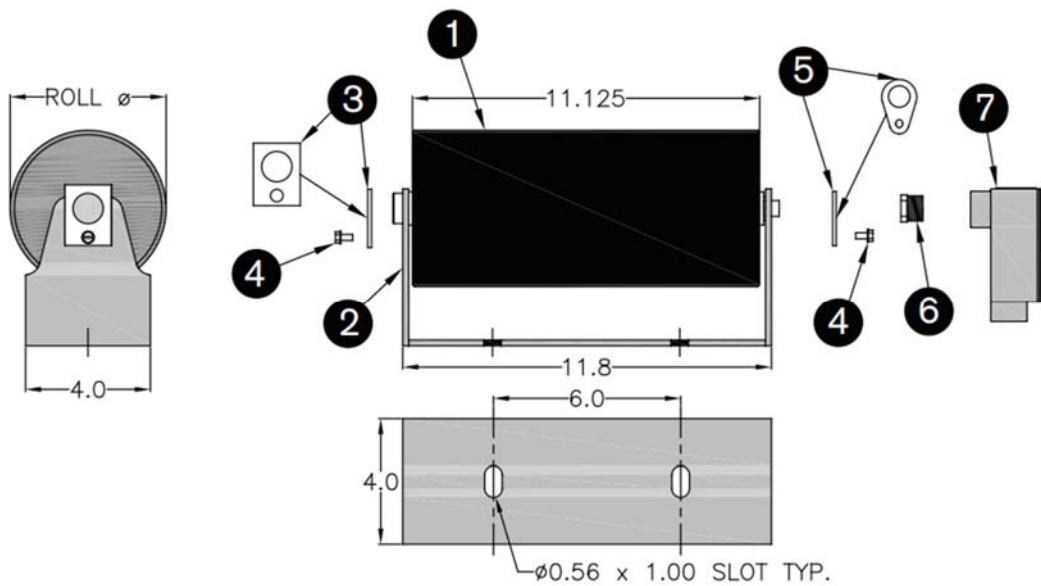

FIGURE 3.1: 90° Elbow Conduit Access Port.

ASSEMBLY COMPONENTS			
ITEM	QTY	DESCRIPTION	PART #
1	1	Smart Roll	TABLE
2	1	Universal Mount Frame	38040
3	1	D End Clip	47117
4	2	#12-3/8" Self Tapping Screw	31880
5	1	B End Clip	31800
6	1	Hex Bushing	34461
7	1	90° Elbow Conduit Access Port	34452

UNIVERSAL MOUNT SMART ROLLS		
ROLL Ø	ASSEMBLY PART #	ROLL ONLY PART #
5.0	SAD5UMSB – 1P	SAD5TE30SB – 1P
5.0	SAD5UMSB – 2P	SAD5TE30SB – 2P
5.0	SAD5UMSB – 6P	SAD5TE30SB – 6P
6.0	SAD6UMSB – 1P	SAD6TE30SB – 1P
6.0	SAD6UMSB – 2P	SAD6TE30SB – 2P
6.0	SAD6UMSB – 6P	SAD6TE30SB – 6P
5.5	SAD5UMSB – 2PL4	SAD5TE30SB – 2PL4
6.5	SAD5UMSB – 2PL4	SAD6TE30SB – 2PL4



TROUGHING SMART ROLL MOUNTING INSTRUCTIONS:

Attention must be given to the location of the Smart Roll so that it is always in contact with the belt. Failure to mount properly may void warranty and could cause damage to conveyor belt and other components.

NOTE: Care must be taken to avoid scraped, pinched, or crushed wiring. Wires that are scraped, pinched, or crushed during shipping, handling or installation will void the warranty.

1. Identify the Smart Roll as a Troughing Smart Roll and select the mounting site on the conveyor. The Troughing Smart Roll is designed to be placed in the wing roll position of a PPI CEMA C or D 20°, 35°, or 45° Equal Roll troughing frame.
2. Determine which side of the conveyor is desirable for running the conduit/wires for the Smart Roll. *It is advisable to route the wires/conduit for the Smart Roll away from electrical power conduit as the electrical power may cause electromagnetic interference (EMI) in the signal from the Smart Roll. If EMI is present the signal from the Smart Roll may not make it to the Smart Monitor or PLC. This will result in the Smart Monitor or PLC getting faulty readings.*
3. Remove the wing roll from the troughing idler on the side the wires/conduit will be run. Keep the end clip, screw, and the center clip.
4. Place the Smart Roll in the troughing idler with the wiring end in the end bracket and the non-wired end in the center bracket. Take care that the wiring is not crushed. Ensure that the slots on the Smart Roll shaft are turned in the correct orientation to allow the Smart Roll to drop fully into the brackets.
5. Replace the center clip in the center bracket.
6. Unscrew the hex bushing from the wired end of the Smart Roll and carefully slide it over the wiring and set aside to be replaced later.
7. Slide the wires through the largest hole of the end clip and lock this end of the Smart Roll into the end bracket using the end clip and the self-tapping screw.
8. Slide the hex bushing previously removed over the wiring and thread it onto the shaft.

TROUGHING SMART ROLL WIRING:

1. Disconnect and lockout power before starting wiring procedure.

The Smart Roll is provided with a ½ inch 90° elbow conduit access port. The Smart Roll cable is 2 wire, 22

AWG, PVC jacket, PVC insulation, and 6 feet in length. No set-up is required to the sensor inside the Smart Roll. It is factory set and maintenance free.

DO NOT apply voltage directly across the wires of the Smart Roll Sensor, permanent damage may result. The Smart Roll is designed to be used with a Smart Monitor, PLC or similar device.

DO NOT use an incandescent light bulb as a load. An overload will occur due to extremely high cold current.

DO NOT operate without a load. A dead short will result which may cause irreparable damage.

DO NOT directly operate a motor with the sensor. Always use a relay or other appropriate device.

2. At this point a 2 wire cable needs to be routed from the control box housing the Smart Monitor to the Smart Roll. It is recommended to use minimum of 22 AWG shielded cable. Shielded cable eliminates electromagnetic interference (EMI). It is advisable to route the wires/conduit for the Smart Roll away from electrical power conduit as the electrical power may cause electromagnetic interference (EMI) in the signal from the Smart Roll. If EMI is present the signal from the Smart Roll may not make it to the Smart Monitor or PLC. This will result in the Smart Monitor or PLC getting faulty readings.

Conduit from the control box to the Smart Roll offers more protection to the cable. Any nick, gouge or cut in the cable wiring could prevent the sensor signal from reaching the Smart Monitor.

PPI is not capable of being aware of all site and industry electrical requirements for an application, and cannot be held liable for non-compliant installations. The product has been designed to be capable of meeting many requirements, and a qualified individual should review the connection plan prior to installation. Connection of conduit to 90° elbow conduit access port does not meet intrinsically safe requirements.

DO NOT PULL THE WIRES CONNECTED TO THE SMART ROLL. Pulling wire from inside the roll will cause damage and void warranty. Be sure to protect the wire near elbow threads and all corners, as this may damage the wire/insulation.

3. Remove the cover from the 90° elbow conduit access port and route the Smart Roll wires and the wires from the control box through the conduit opening in the 90° elbow access port and out the rectangular opening.
4. Attach the conduit to the 90° elbow access port.
5. Attach the Smart Roll wires to the wires from the control box. Cut wires to proper length to fit in junction box. DO NOT apply power to the sensor at this time. The Smart Monitor or PLC provides the power for the Smart Roll. To avoid damage, verify the circuit meets the sensor specifications shown in Appendix A4 prior to applying power:
6. Reinstall junction box lid and tighten screws to secure.
7. Proceed to Section 4: "Wiring the Smart Monitor."

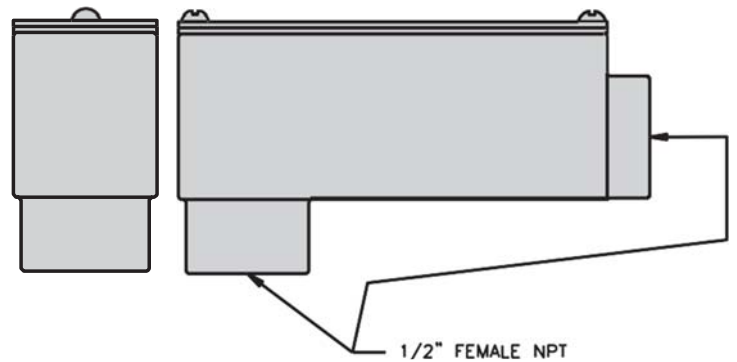

FIGURE 3.1: 90° Elbow Conduit Access Port

TROUGHING SMART ROLL DIAGRAM AND PARTS LIST:

See Troughing Smart Roll Part Numbers in Appendix A6.

ASSEMBLY COMPONENTS				
ITEM	QTY	DESCRIPTION	PART #	
1	1	Smart Roll	TABLE	
2	1	Hex Bushing	34461	Provided with Smart Roll
3	1	90° Elbow Conduit Access Port	34452	Provided with Smart Roll
4	1	20° Center Clip 35° Center Clip 45° Center Clip	00820 00835 00845	Not provided with Smart Roll. Use existing Center Clip or order required part number.
5	1	B End Clip	31800	Not provided with Smart Roll. Use existing End Clip or order part number 31800.
6	1	#12-3/8" Screw	31880	Not provided with Smart Roll. Use existing Screw or order part number 31880.

STANDARD PPI CEMA C OR D TROUGHING IDLER (NOT INCLUDED WITH SMART ROLL)

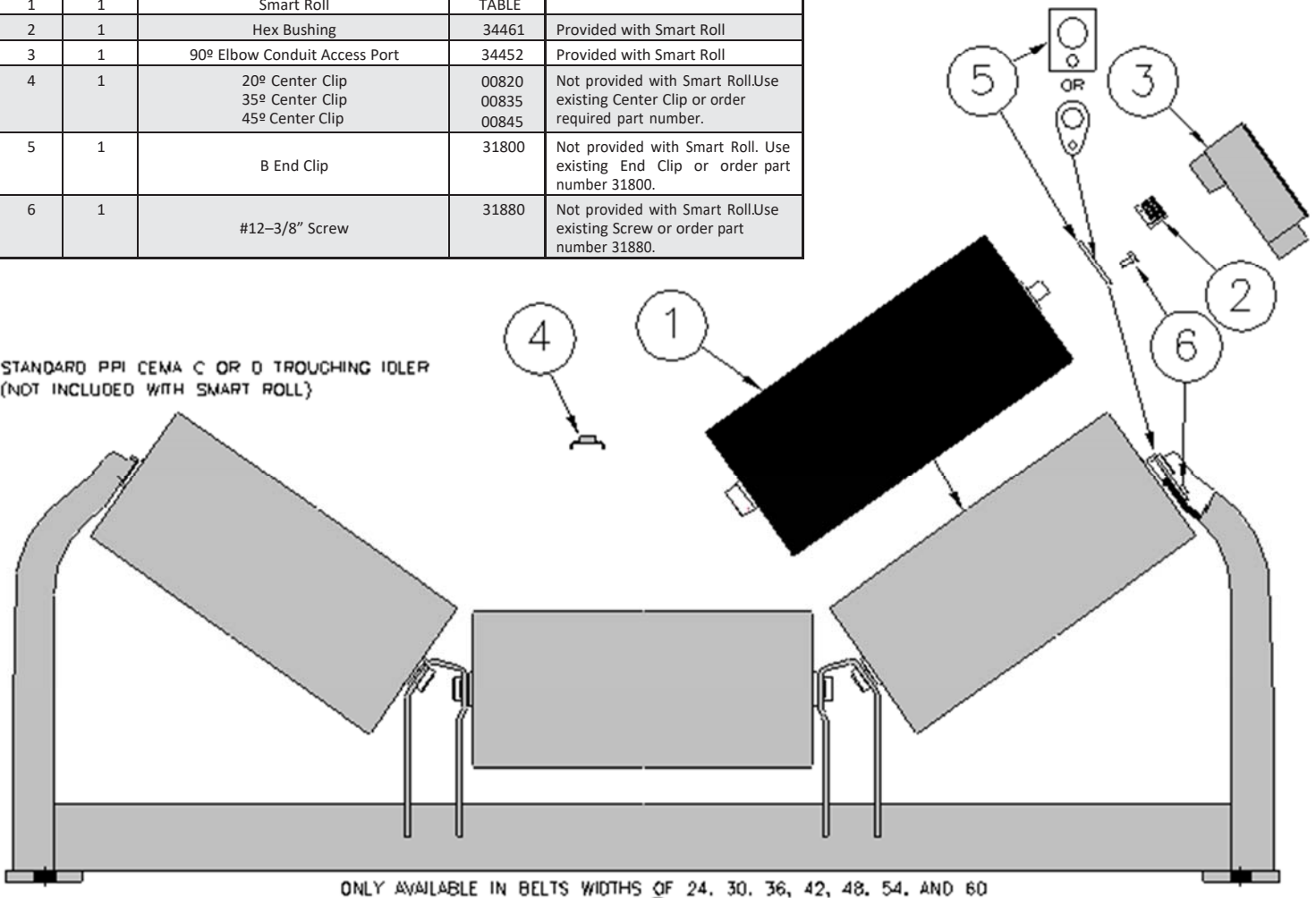

ONLY AVAILABLE IN BELTS WIDTHS OF 24, 30, 36, 42, 48, 54, AND 60

RETURN SMART ROLL MOUNTING INSTRUCTIONS:

Attention must be given to the location of the Smart Roll so that it is always in contact with the belt. Failure to mount properly may void warranty and could cause damage to conveyor belt and other components.

NOTE: Care must be taken to avoid scraped, pinched, or crushed wiring. Wires that are scraped, pinched, or crushed during shipping, handling or installation will void the warranty.

1. Identify the Smart Roll as a Return Smart Roll and select the mounting site on the conveyor. The Return Smart Roll is designed to be placed on the return belt side of the conveyor in PPI D drop brackets (not included).
2. Determine which side of the conveyor is desirable for running the conduit/wires for the Smart Roll. It is advisable to route the wires/conduit for the Smart Roll away from electrical power conduit as the electrical power may cause electromagnetic interference (EMI) in the signal from the Smart Roll. If EMI is present the signal from the Smart Roll may not make it to the Smart Monitor or PLC. This will result in the Smart Monitor or PLC getting faulty readings.
3. If existing PPI drop brackets are in place loosen the bolts holding the drop brackets to the conveyor structure. If existing drop brackets will not work install new PPI drop brackets loosely.
4. Unscrew the hex bushing from the wired end of the Smart Roll and carefully slide it over the wiring and set aside to be replaced later.
5. Wired end of the Smart Roll: Run the wires from the Smart Roll through the drop bracket on the side the conduit will run. Place the Smart Roll end into the drop bracket so the Smart Roll is held in the drop bracket by the flats on the shaft. Ensure that the Smart Roll wiring will not be crimped, scraped, pinched or crushed when installing the Smart Roll. Slide the wiring through the end clip and over the shaft and lock the Smart Roll into the drop bracket using this end clip with the self-tapping screw. Slide the wiring through the hex bushing previously removed and thread it onto the shaft.

6. Place the non-wired end of the Smart Roll in the other drop bracket so the roll is held in place by the flats on the shaft and the drop bracket slot. Lock this end of the Smart Roll into the drop bracket using the D end clip and self-tapping screw.
7. Align the Smart Roll so it is square and horizontal with the centerline of the conveyor frame. Tighten bolts on the drop brackets to the conveyor frame.

RETURN SMART ROLL WIRING:

1. Disconnect and lockout power before starting wiring procedure.

The Smart Roll is provided with a ½ inch 90° elbow conduit access port. The Smart Roll cable is a 2 wire, 22 AWG, PVC jacket, PVC insulation, and 6 feet in length. No set-up is required to the sensor inside the Smart Roll. It is factory set and maintenance free.

DO NOT apply voltage directly across the wires of the Smart Roll Sensor, permanent damage may result. The Smart Roll is designed to be used with a Smart Monitor, PLC or similar device.

DO NOT use an incandescent light bulb as a load. An overload will occur due to extremely high cold current.

DO NOT operate without a load. A dead short will result which may cause irreparable damage.

DO NOT directly operate a motor with the sensor. Always use a relay or other appropriate device.

2. At this point a 2 wire cable needs to be routed from the control box housing the Smart Monitor to the Smart Roll. It is recommended to use minimum of 22 AWG shielded cable. Shielded cable eliminates electromagnetic interference (EMI). *It is advisable to route the wires/conduit for the Smart Roll away from electrical power conduit as the electrical power may cause electromagnetic interference (EMI) in the signal from the Smart Roll. If EMI is present the signal from the Smart Roll may not make it to the Smart Monitor or PLC. This will result in the Smart Monitor or PLC getting faulty readings.*

Conduit from the control box to the Smart Roll offers more protection to the cable. Any nick, gouge or cut in the cable wiring could prevent the sensor signal from reaching the Smart Monitor.

PPI is not capable of being aware of all site and industry electrical requirements for an application, and cannot be held liable for non-compliant installations. The product has been designed to be capable of meeting many requirements, and a qualified individual should review the connection plan prior to installation. Connection of conduit to 90° elbow conduit access port does not meet intrinsically safe requirements.

DO NOT PULL THE WIRES CONNECTED TO THE SMART ROLL. Pulling wire from inside the roll will cause damage and void warranty. Be sure to protect the wire near elbow threads and all corners, as this may damage the wire/insulation.

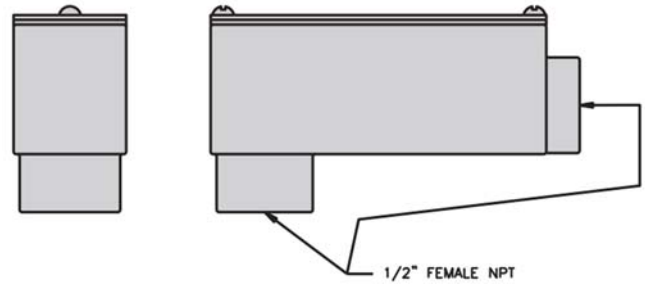

FIGURE 3.1 90° Elbow Conduit Access Port.

3. Remove the cover from the 90° elbow conduit access port and route the Smart Roll wires and the wires from the control box through the conduit opening in the 90° elbow access port and out the rectangular opening.
4. Attach the conduit to the 90° elbow access port.
5. Attach the Smart Roll wires to the wires from the control box. Cut wires to proper length to fit in junction box. DO NOT apply power to the sensor at this time. The Smart Monitor or PLC provides the power for the Smart Roll. To avoid damage, verify the circuit meets the sensor specifications shown in Appendix A4 prior to applying power:
6. Reinstall junction box lid and tighten screws to secure.
7. Proceed to Section 4: "Wiring the Smart Monitor."

RETURN SMART ROLL DIAGRAM & PARTS

LIST:

See Flat Return Smart Roll Part Numbers in Appendix A6.

ASSEMBLY COMPONENTS			
ITEM	QTY	DESCRIPTION	PART #
1	1	Smart Roll	TABLE
2	1	Drop Bracket	N/A
3	1	D End Clip	47117
4	2	#12-3/8" Self Tapping Screw	31880
5	1	B End Clip	31800
6	1	Hex Bushing	34461
7	1	90° Elbow Conduit Access Port	34452

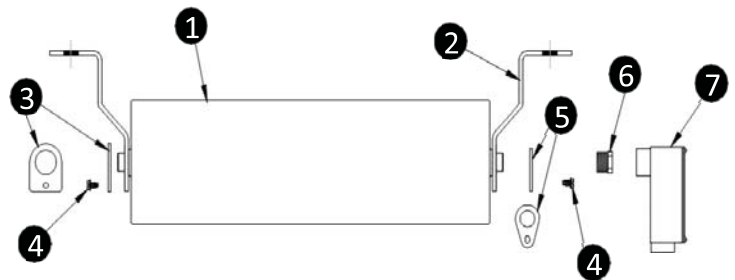

A4. SMART ROLL SENSOR WIRING DIAGRAMS AND SPECIFICATIONS

Figures A4.1, A4.2, and A4.3 show Smart Roll Sensor wiring diagrams. For these diagrams, the Smart Monitor or PLC provides the load.

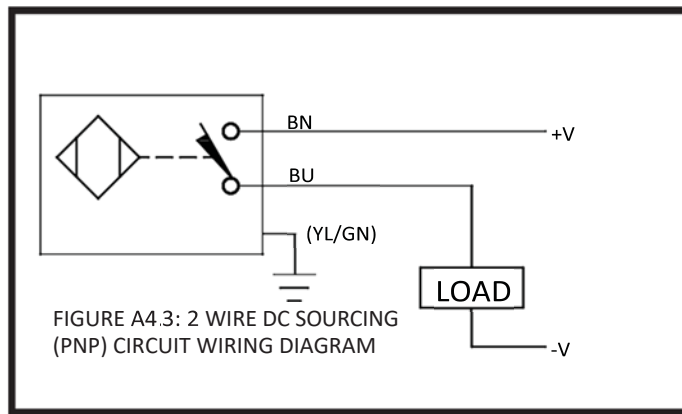
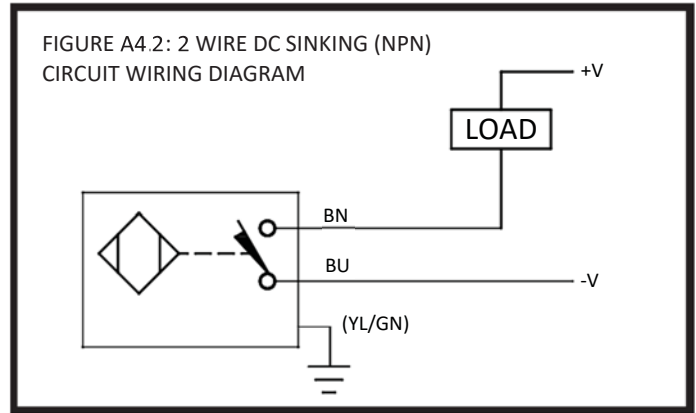
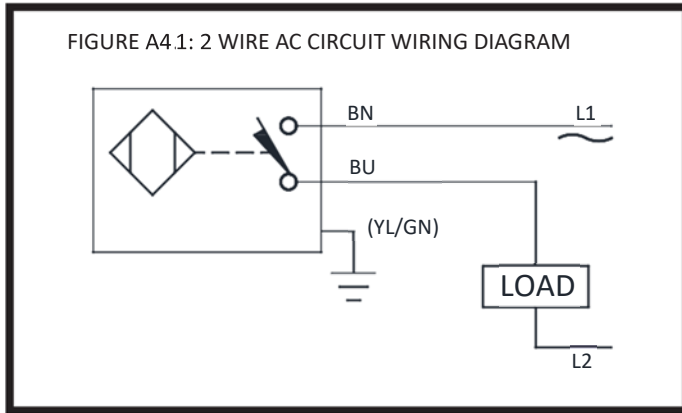

SENSOR SPECIFICATION:

- 2 wire AC/DC inductive sensor
- 20–250 VAC, 10 –300 VDC
- Short Circuit and Overload Protection
- Normally Open
- 2 meter cable, PVC jacket; 22 AWG copper conductors, PVC insulated line

Frequency: 50-60 Hz

Differential Travel (Hysteresis): 3-15% (5% typical)

Voltage Drop Across Conducting Sensor: $\leq 6.0V$ at 100 mA

Continuous Load Current: ≤ 100 mA

Trigger Current for Overload Protection: ≥ 220 mA Off

State (Leakage) Current: ≤ 1.7 mA

Minimum Load Current: ≥ 3.0 mA

Inrush Current: $\leq 1.0A$ ($\leq 30ms$, 15% Duty Cycle) Time

Delay Before Availability: ≤ 60 ms

Power-On Effect: Per IEC 947-5-2

Transient Protection: Per EN 60947-5-2

Operating Temperature: $-25^{\circ}C$ to $+70^{\circ}C$ ($-13^{\circ}F$ to $158^{\circ}F$)

Repeatability: $\leq 2\%$ of Rated Operating Distance

Temperature Drift: $\pm 10\%$

PART NUMBER 37545 SMART MONITOR 120VAC 4-20mA OUTPUT

Description:
Smart Monitor 37545 converts rotary shaft speed (RPM) into analog 4-20mA output. This allows “true-slip” monitoring during the critical ramp-up period of conveyors. The Smart Monitor 37545 interfaces directly with the customer’s PLC. The Smart Monitor conveniently mounts inside an existing electrical panel or O.E.M. control box. The aluminum mounting plate is removable for mounting to DIN rail. The up-front LCD screen conveniently shows the current RPM in real time.

Installation:

1. Disconnect AC power before proceeding with installation
2. Mount the Smart Monitor inside an existing control panel or other suitable protective enclosure. See Figure A5.3 for Smart Monitor mounting dimensions.
3. Table A5.1 shows connection details for the terminal strip. Make needed connections.
4. Install Smart Roll. See Section 2: “Installing and Mounting the Smart Roll.”

Set-up and Display Indicators:

When power is applied to the unit, the display will show the following: “000” RPM (Displays the actual RPM from the remote speed sensor).

“Line Open” – If displayed, indicates user should check 4-20mA line. 0-500 ohm is maximum line resistance.

“10-XXXX RPM” – Displays the current speed range. If this is NOT the correct range required for your installation, you can select from 23 other preset speed ranges by following the steps below:

1. Depress and hold the “set” button for approximately 4 seconds. The display will now change to show ranges from 100 RPM top range to 6000 RPM top range.
2. Now using the “arrow” keys, select the desired range from the list.
3. With the correct range “highlighted,” depress and hold the “set” button for approximately 4 seconds. The display will now change back to normal operation with the new RPM range shown on the screen.
NOTE: If you do not make a selection within approximately 10 seconds, the display will go back to normal operation and keep the existing speed range.
NOTE: This new model has ALL the “previous style” Smart Monitor speed ranges included in the firmware, this allows for the models to be replaced without having to change computer programming.

Application / Speed Information:

All models have a preset low end RPM range of 10 RPM (0.1666 Hz X 60). The following formulas/examples can be used to determine the Frequency Range (SPAN) and corresponding 4-20mA output at any monitored speed.

1. Convert top end RPM into a Frequency in hertz (Hz).
 $XXXX \text{ RPM} / 60 = XXX.X \text{ Hz}$
2. Subtract Frequency in hertz from 0.1666 Hz (10 RPM)
 $XXX.X \text{ Hz} - 0.1666 \text{ Hz} = XXX.X \text{ SPAN in RPM}$
3. Divide the SPAN in RPM by 160 = RPM per each 0.1mA increment of output.
 $XXX.X \text{ RPM} / 160 = XX \text{ RPM per .1mA output}$

TERMINAL	CONNECTION
FRONT	
1	No connection
2	No connection
3	4-20mA Output – Positive (+)
4	4-20mA Output – Negative (-)
5	No connection
6	No connection
7	Sensor Input (+)
8	Sensor Input Common (-)
BACK	
9	No connection
10	No connection
11	No connection
12	No connection
13	No connection
14	No connection
15	AC Input (N)
16	AC Input (H)

TABLE A5.1 37545 Smart Monitor terminal connections

AVAILABLE TOP END SPEED SETTINGS		
SCREEN 1		
100 RPM	225 RPM	350 RPM
150 RPM	260 RPM	360 RPM
160 RPM	300 RPM	400 RPM
200 RPM	325 RPM	500 RPM
SCREEN 2		
600 RPM	1200 RPM	4100 RPM
660 RPM	1800 RPM	4500 RPM
800 RPM	2000 RPM	6000 RPM
1000 RPM	2500 RPM	

TABLE A5.2: Available Top End Speed Settings

Example below shows the speed information for 150 RPM:

This example has an INPUT FREQUENCY RANGE of 0.166 Hz to 2.50 Hz. By installing 1 (one) target on the roller or shaft, the following formula can be used to convert to RPM's:

$$\text{INPUT FREQUENCY} * 60 = \text{RPM}$$

$$\text{Examples: } 0.166 \text{ Hz} * 60 = 9.96 \text{ RPM}$$

$$1.33 \text{ Hz} * 60 = 79.80 \text{ RPM}$$

$$2.50 \text{ Hz} * 60 = 150.00 \text{ RPM}$$

This example unit has a factory set span of 2.334 Hz (2.50 Hz - 0.166 Hz). Multiplying 2.334 Hz * 60 will give the span in RPM's.

$$2.334 \text{ Hz} * 60 = 140.04 \text{ RPM}$$

Dividing 140.04 / 160 will give the RPM resolution for each .1mA increment.

$$140.04 / 160 = 0.87 \text{ RPM per .1mA output}$$

By adding additional targets to the roller or shaft, a lower RPM range can be obtained. The following examples will show how to calculate the speed range for 4 (four) targets.

$$\text{INPUT FREQUENCY} * 60 / 4 \text{ TARGETS} = \text{ACTUAL RPM}$$

$$\text{Examples: } 0.166 \text{ Hz} * 60 / 4 = 2.49 \text{ RPM}$$

$$1.33 \text{ Hz} * 60 / 4 = 19.95 \text{ RPM}$$

$$2.50 \text{ Hz} * 60 / 4 = 37.50 \text{ RPM}$$

CONCLUSION:

By changing the number of targets on the roller or shaft, different speed ranges can be obtained from the same model.

Examples: 1 Target = 9.96 RPM to 150.00 RPM

2 Targets = 4.98 RPM to 75.00 RPM

4 Targets = 1.77 RPM to 37.50 RPM

Specification - 37545 Smart Monitor 120VAC
4029mA output

- AC Input: 90-140 VAC 50/60 Hz @ 6 W
- Fuse Protected: 1 amp
- Output: Proportional 4-20mA D. C.
- Linearity: Better than 1%
- Accuracy: Better than 1%
- Repeatability: Better than 5%

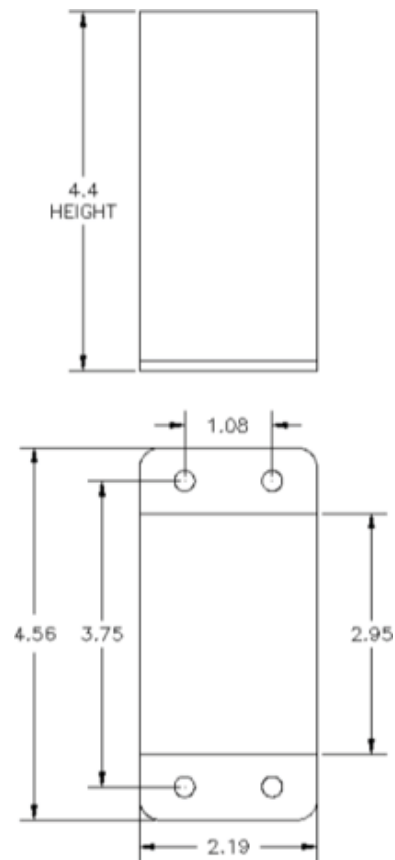

FIGURE A5.3: 37543
Smart Monitor dimensions

PART NUMBER 47268 SMART MONITOR 9-36 VDC

Description:

The Smart Monitor 47268 provides an under speed switch by monitoring 6-3,000 pulses per minute (PPM) and has a user-programmable 0-30 second ramp-up timer. The Smart Monitor is designed to be located in an electrical panel or O.E.M. control box. A removable plate allows for mounting to a DIN rail. The digital display shows the current PPM in real time. This eliminates setting "guesswork" by constantly showing the actual PPM being monitored.

Installation:

1. Disconnect AC power before proceeding with installation
2. Mount the Smart Monitor inside an existing control panel or other suitable protective enclosure. See Figure A5.5 for Smart Monitor mounting dimensions.
3. Table A5.4 shows connection details for the terminal strip. Make needed connections.
4. Install Smart Roll. See Section 2: "Installing and Mounting the Smart Roll."

Trip Point Set-up:

Apply power to Smart Monitor. If this is the first time powering unit up, the default trip point is 6 RPM or PPM, the built-in ramp-up timer is disabled and the relay is off (TRIP: 0006 / RAMP: 0S / REL: OFF). Read through the following instructions before starting the set-up procedure.

1. Momentarily depress the down arrow button once to highlight "TEST."
2. Momentarily depress the down arrow a second time to highlight "TRIP."
3. Momentarily depress the SET button to begin setting unit to the trip speed desired, starting with the 4 digit (the 1000s place). When highlighted, use the up/down arrow buttons to change number as needed. When 4th place is set correctly, momentarily depress the SET button to begin setting the 3rd (100s place) digit. Again, use the up/down arrow buttons to change the number. When set correctly, momentarily depress the SET button to begin setting the 2nd (10s place) digit. Use up/down arrow buttons as before to change the number, and once set, momentarily depress the SET button to begin setting the 1st and final digit.
4. Review your settings for accuracy. If a digit needs to be adjusted, momentarily depress the SET button one or more times to get to the proper digit, then use the up/down arrows to switch number and when satisfied, press and hold the SET button – the RPM setting will highlight and then go back to normal. The SET button can then be released. The RPM setting will be maintained in non-volatile memory until changed by the operator.

TERMINAL	CONNECTION
FRONT	
1	No connection
2	No connection
3	No connection
4	No connection
5	No connection
6	No connection
7	Sensor Input (+)
8	Sensor Input Common (-)
BACK	
9	N/C (2)
10	Common (2)
11	N/O (2)
12	N/C (1)
13	Common (1)
14	N/O (1)
15	(-) 9-36VDC
16	(+) 9-36VDC

TABLE A5.4: 47268 Smart Monitor terminal connections

Ramp-up Timer Set-up:

The default setting for the ramp-up timer is 0 seconds (timer disabled). To set the timer for a 1 to 30 second ramp-up period, follow the procedure below:

1. Momentarily depress the down arrow to highlight "RAMP."
2. Momentarily depress the SET button to highlight the timer in seconds.
3. Use the up/down arrow buttons to increment the timer from 0 seconds up to a max of 30 seconds.
4. When satisfied, press and hold the SET button – the timer setting will highlight then return to normal.

Testing Procedure:

A test function has been provided to allow the operator to de-energize the internal control relay and stop the monitored equipment. To activate a test shutdown,

1. Momentarily depress the down arrow button once to highlight "TEST."
2. Depress and HOLD the SET button for approximately 3 seconds – the control relay will de-energize.
3. Release the SET button. There is a safety delay that will keep the control relay off for 10 seconds after it has de-energized. The relay will automatically re-energize after the delay if RPM speed above the programmed trip point is detected.

Adjusting Ramp-up Timer after Smart Monitor is Installed and Wired into Control Circuit:

There may be times when after installation the ramp-up timer is found to be set to too short a period of time. This presents a problem because when the equipment being monitored is shut down, there is also no power going through the Smart Monitor. The following procedure should be performed to allow setting of the ramp-up timer on the next equipment start-up cycle:

1. Before starting the monitored equipment, depress and hold the SET button until the equipment start-up sequence has been initiated – the display of the Smart Monitor will be powered on, "RAMP" will be highlighted and the control relay (REL) will be "ON" (energized).
2. Release the SET button then use the up arrow button to increment the ramp-up timer to the desired number of seconds (max of 30).
3. Depress and release the SET button to "write" the new ramp-up timer setting in to the Smart Monitor. The new setting will be used on the next equipment start-up sequence.

Specification - 47268 Smart Monitor 9-36 VDC

- DC Input: 9-36 VDC
- Fuse Protected: 1 amp
- Speed Range: 6-3000 pulses per minute
- Relay Contacts: DPDT 5 amp @ 120VAC
- Safety Delay 1 second
- Response Time: 1 second or less

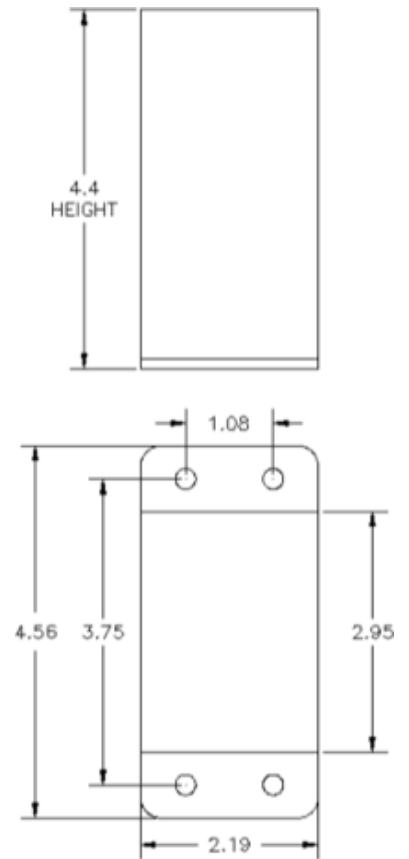

FIGURE A5.5: 47268 Smart Monitor dimensions.

PART NUMBER 47269 SMART MONITOR 220VAC 4-20MA OUTPUT

Description:

Smart Monitor 47269 converts rotary shaft speed (RPM) into analog 4-20mA output. This allows “true-slip” monitoring during the critical ramp-up period of conveyors. The Smart Monitor 37545 interfaces directly with the customer’s PLC. The Smart Monitor conveniently mounts inside an existing electrical panel or O.E.M. control box. The aluminum mounting plate is removable for mounting to DIN rail. The up-front LCD screen conveniently shows the current RPM in real time.

Installation:

1. Disconnect AC power before proceeding with installation
2. Mount the Smart Monitor inside an existing control panel or other suitable protective enclosure. See Figure A5.8 for Smart Monitor mounting dimensions.
3. Table A5.6 shows connection details for the terminal strip. Make needed connections.
4. Install Smart Roll. See Section 2: “Installing and Mounting the Smart Roll”.

Set-up and Display Indicators:

When power is applied to the unit, the display will show the following: “000” RPM (Displays the actual RPM from the remote speed sensor).

“Line Open” – If displayed, indicates user should check 4-20mA line. 0-500 ohm is maximum line resistance.

“10-XXXX RPM” – Displays the current speed range. If this is NOT the correct range required for your installation, you can select from 23 other preset speed ranges by following the steps below:

5. Depress and hold the “set” button for approximately 4 seconds. The display will now change to show ranges from 100 RPM top range to 6000 RPM top range.
6. Now using the “arrow” keys, select the desired range from the list.
7. With the correct range “highlighted,” depress and hold the “set” button for approximately 4 seconds. The display will now change back to normal operation with the new RPM range shown on the screen.

NOTE: If you do not make a selection within approximately 10 seconds, the display will go back to normal operation and keep the existing speed range.

NOTE: This new model has ALL the “previous style” Smart Monitor speed ranges included in the firmware, this allows for the models to be replaced without having to change computer programming.

Application / Speed Information:

All models have a preset low end RPM range of 10 RPM (0.1666 Hz X 60).

The following formulas/examples can be used to determine the Frequency Range (SPAN) and corresponding 4-20mA output at any monitored speed.

1. Convert top end RPM into a Frequency in hertz (Hz).
 $XXXX \text{ RPM} / 60 = XXX.X \text{ Hz}$
2. Subtract Frequency in hertz from 0.1666 Hz (10 RPM)
 $XXX.X \text{ Hz} - 0.1666 \text{ Hz} = XXX.X \text{ SPAN in RPM's}$
3. Divide the SPAN in RPM by 160 = RPM's per each 0.1mA increment of the output.
 $XXX.X \text{ RPM} / 160 = XX \text{ RPM per } 1\text{mA output}$

TERMINAL	CONNECTION
FRONT	
1	No connection
2	No connection
3	4-20mA Output – Positive (+)
4	4-20mA Output – Common (-)
5	No connection
6	No connection
7	Sensor Input (+)
8	Sensor Input Common (-)
BACK	
9	No connection
10	No connection
11	No connection
12	No connection
13	No connection
14	No connection
15	AC Input – 200-250VAC
16	AC Input – 200-250VAC

TABLE A5.6: 47269 Smart Monitor terminal connections

AVAILABLE TOP END SPEED SETTINGS		
SCREEN 1		
100 RPM	225 RPM	350 RPM
150 RPM	260 RPM	360 RPM
160 RPM	300 RPM	400 RPM
200 RPM	325 RPM	500 RPM
SCREEN 2		
600 RPM	1200 RPM	4100 RPM
660 RPM	1800 RPM	4500 RPM
800 RPM	2000 RPM	6000 RPM
1000 RPM	2500 RPM	

TABLE A5.2: Available Top End Speed Settings

Example below shows the speed information for 150 RPM:
 This example has an INPUT FREQUENCY RANGE of 0.166 Hz to 2.50 Hz. By installing 1 (one) target on the roller or shaft, the following formula can be used to convert to RPM's:

INPUT FREQUENCY * 60 = RPM

Examples: 0.166 Hz * 60 = 9.96 RPM

1.33 Hz * 60 = 79.80 RPM

2.50 Hz * 60 = 150.00 RPM

This example unit has a factory set span of 2.334 Hz (2.50 Hz - 0.166 Hz). Multiplying 2.334 Hz * 60 will give the span in RPM's.

2.334 Hz * 60 = 140.04 RPM

Dividing 140.04 / 160 will give the RPM resolution for each .1mA increment.

140.04 / 160 = 0.87 RPM per .1mA output

By adding additional targets to the roller or shaft, a lower RPM range can be obtained. The following examples will show how to calculate the speed range for 4 (four) targets.

INPUT FREQUENCY * 60 / 4 TARGETS = ACTUAL RPM

Examples: 0.166 Hz * 60 / 4 = 2.49 RPM

1.33 Hz * 60 / 4 = 19.95 RPM

2.50 Hz * 60 / 4 = 37.50 RPM

CONCLUSION: By changing the number of targets on the roller or shaft, different speed ranges can be obtained from the same model.

Examples: 1 Target = 9.96 RPM to 150.00 RPM

2 Targets = 4.98 RPM to 75.00 RPM

4 Targets = 1.77 RPM to 37.50 RPM

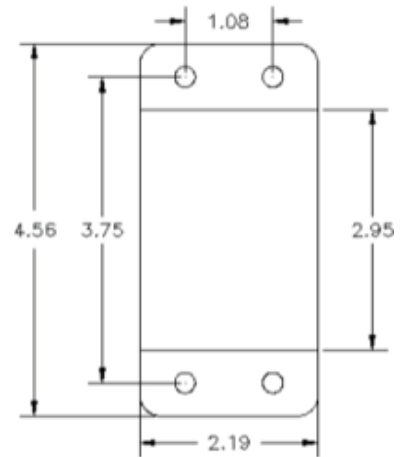
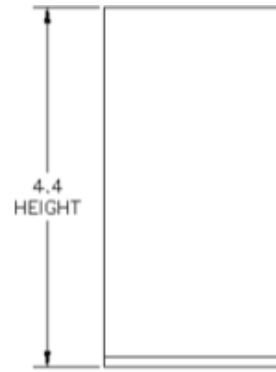

FIGURE A5.8: 47269 Smart Monitor dimensions.

Specification - 47269 Smart Monitor 220VAC 4-20mA output

- AC Input: 90-140 VAC 50/60 Hz @ 6 W
- Fuse Protected: 1 amp
- Output: Proportional 4-20mA D. C.
- Linearity: Better than 1%
- Accuracy: Better than 1%
- Repeatability: Better than 5%

A6. PART NUMBERS

SMART MONITOR PART NUMBERS

PART NUMBER	PULSES PER REVOLUTION	INPUT VOLTAGE	OUTPUT
37543	6 – 3,000	120 VAC 10 W	Relay contacts
37545	6 – 3,000	120 VAC 6 W	4-20 mA
47268	6 – 3,000	9-36 vdc	Relay contacts
47269	6 – 3,000	220 VAC 4 W	4-20mA

CLEAN SIDE RETURN SMART ROLL PART NUMBERS

PART NUMBER	PULSES PER REVOLUTION		LAGGING THICKNESS	DIAMETER	ROLL LENGTH	BELT WIDTH
SAD5CSRSB-1PL4	1	PULSE	1/4" Lagging	5.5	11.125	All
SAD5CSRSB-2PL4	2	PULSE	1/4" Lagging	5.5	11.125	All
SAD5CSRSB-6PL4	6	PULSE	1/4" Lagging	5.5	11.125	All
SAD6CSRSB-1PL4	1	PULSE	1/4" Lagging	6.5	11.125	All
SAD6CSRSB-2PL4	2	PULSE	1/4" Lagging	6.5	11.125	All
SAD6CSRSB-6PL4	6	PULSE	1/4" Lagging	6.5	11.125	All

UNIVERSAL MOUNT SMART ROLL PART NUMBERS

PART NUMBER	PULSES PER REVOLUTION		LAGGING THICKNESS	DIAMETER	ROLL LENGTH	BELT WIDTH
SAD5UMSB-2PL4	2	PULSE	1/4" Lagging	5.5	11.125	All
SAD6UMSB-2PL4	2	PULSE	1/4" Lagging	6.5	11.125	All
SAD5UMSB-1P	1	PULSE	No Lagging	5.0	11.125	All
SAD5UMSB-2P	2	PULSE	No Lagging	5.0	11.125	All
SAD5UMSB-6P	6	PULSE	No Lagging	5.0	11.125	All
SAD6UMSB-1P	1	PULSE	No Lagging	6.0	11.125	All
SAD6UMSB-2P	2	PULSE	No Lagging	6.0	11.125	All
SAD6UMSB-6P	6	PULSE	No Lagging	6.0	11.125	All

TROUGHING EQUAL SMART ROLL PART NUMBERS

PART NUMBER	PULSES PER REVOLUTION	LAGGING THICKNESS	ROLL DIA	ROLL LENGTH	BELT WIDTH	
SAD5TE24SB-1P	1	PULSE	no lagging	5.0	8.938	24
SAD5TE30SB-1P	1	PULSE	no lagging	5.0	11.125	30
SAD5TE36SB-1P	1	PULSE	no lagging	5.0	13.250	36
SAD5TE42SB-1P	1	PULSE	no lagging	5.0	15.438	42
SAD5TE48SB-1P	1	PULSE	no lagging	5.0	17.625	48
SAD5TE54SB-1P	1	PULSE	no lagging	5.0	19.750	54
SAD5TE60SB-1P	1	PULSE	no lagging	5.0	21.750	60

SAD5TE24SB-2P	2	PULSES	no lagging	5.0	8.938	24
SAD5TE30SB-2P	2	PULSES	no lagging	5.0	11.125	30
SAD5TE36SB-2P	2	PULSES	no lagging	5.0	13.250	36
SAD5TE42SB-2P	2	PULSES	no lagging	5.0	15.438	42
SAD5TE48SB-2P	2	PULSES	no lagging	5.0	17.625	48
SAD5TE54SB-2P	2	PULSES	no lagging	5.0	19.750	54
SAD5TE60SB-2P	2	PULSES	no lagging	5.0	21.750	60

SAD5TE24SB-6P	6	PULSES	no lagging	5.0	8.938	24
SAD5TE30SB-6P	6	PULSES	no lagging	5.0	11.125	30
SAD5TE36SB-6P	6	PULSES	no lagging	5.0	13.250	36
SAD5TE42SB-6P	6	PULSES	no lagging	5.0	15.438	42
SAD5TE48SB-6P	6	PULSES	no lagging	5.0	17.625	48
SAD5TE54SB-6P	6	PULSES	no lagging	5.0	19.750	54
SAD5TE60SB-6P	6	PULSES	no lagging	5.0	21.750	60

SAD5TE24SB-1PL4	1	PULSE	1/4" lagging	5.5	8.938	24
SAD5TE30SB-1PL4	1	PULSE	1/4" lagging	5.5	11.125	30
SAD5TE36SB-1PL4	1	PULSE	1/4" lagging	5.5	13.250	36
SAD5TE42SB-1PL4	1	PULSE	1/4" lagging	5.5	15.438	42
SAD5TE48SB-1PL4	1	PULSE	1/4" lagging	5.5	17.625	48
SAD5TE54SB-1PL4	1	PULSE	1/4" lagging	5.5	19.750	54
SAD5TE60SB-1PL4	1	PULSE	1/4" lagging	5.5	21.750	60

SAD5TE24SB-2PL4	2	PULSES	1/4" lagging	5.5	8.938	24
SAD5TE30SB-2PL4	2	PULSES	1/4" lagging	5.5	11.125	30
SAD5TE36SB-2PL4	2	PULSES	1/4" lagging	5.5	13.250	36
SAD5TE42SB-2PL4	2	PULSES	1/4" lagging	5.5	15.438	42
SAD5TE48SB-2PL4	2	PULSES	1/4" lagging	5.5	17.625	48
SAD5TE54SB-2PL4	2	PULSES	1/4" lagging	5.5	19.750	54
SAD5TE60SB-2PL4	2	PULSES	1/4" lagging	5.5	21.750	60

SAD5TE24SB-6PL4	6	PULSES	1/4" lagging	5.5	8.938	24
SAD5TE30SB-6PL4	6	PULSES	1/4" lagging	5.5	11.125	30
SAD5TE36SB-6PL4	6	PULSES	1/4" lagging	5.5	13.250	36
SAD5TE42SB-6PL4	6	PULSES	1/4" lagging	5.5	15.438	42
SAD5TE48SB-6PL4	6	PULSES	1/4" lagging	5.5	17.625	48
SAD5TE54SB-6PL4	6	PULSES	1/4" lagging	5.5	19.750	54
SAD5TE60SB-6PL4	6	PULSES	1/4" lagging	5.5	21.750	60

PART NUMBER	PULSES PER REVOLUTION	LAGGING THICKNESS	ROLL DIA	ROLL LENGTH	BELT WIDTH	
SAD6TE24SB-1P	1	PULSE	no lagging	6.0	8.938	24
SAD6TE30SB-1P	1	PULSE	no lagging	6.0	11.125	30
SAD6TE36SB-1P	1	PULSE	no lagging	6.0	13.250	36
SAD6TE42SB-1P	1	PULSE	no lagging	6.0	15.438	42
SAD6TE48SB-1P	1	PULSE	no lagging	6.0	17.625	48
SAD6TE54SB-1P	1	PULSE	no lagging	6.0	19.750	54
SAD6TE60SB-1P	1	PULSE	no lagging	6.0	21.750	60

SAD6TE24SB-2P	2	PULSES	no lagging	6.0	8.938	24
SAD6TE30SB-2P	2	PULSES	no lagging	6.0	11.125	30
SAD6TE36SB-2P	2	PULSES	no lagging	6.0	13.250	36
SAD6TE42SB-2P	2	PULSES	no lagging	6.0	15.438	42
SAD6TE48SB-2P	2	PULSES	no lagging	6.0	17.625	48
SAD6TE54SB-2P	2	PULSES	no lagging	6.0	19.750	54
SAD6TE60SB-2P	2	PULSES	no lagging	6.0	21.750	60

SAD6TE24SB-6P	6	PULSES	no lagging	6.0	8.938	24
SAD6TE30SB-6P	6	PULSES	no lagging	6.0	11.125	30
SAD6TE36SB-6P	6	PULSES	no lagging	6.0	13.250	36
SAD6TE42SB-6P	6	PULSES	no lagging	6.0	15.438	42
SAD6TE48SB-6P	6	PULSES	no lagging	6.0	17.625	48
SAD6TE54SB-6P	6	PULSES	no lagging	6.0	19.750	54
SAD6TE60SB-6P	6	PULSES	no lagging	6.0	21.750	60

SAD6TE24SB-1PL4	1	PULSE	1/4" lagging	6.5	8.938	24
SAD6TE30SB-1PL4	1	PULSE	1/4" lagging	6.5	11.125	30
SAD6TE36SB-1PL4	1	PULSE	1/4" lagging	6.5	13.250	36
SAD6TE42SB-1PL4	1	PULSE	1/4" lagging	6.5	15.438	42
SAD6TE48SB-1PL4	1	PULSE	1/4" lagging	6.5	17.625	48
SAD6TE54SB-1PL4	1	PULSE	1/4" lagging	6.5	19.750	54
SAD6TE60SB-1PL4	1	PULSE	1/4" lagging	6.5	21.750	60

SAD6TE24SB-2PL4	2	PULSES	1/4" lagging	6.5	8.938	24
SAD6TE30SB-2PL4	2	PULSES	1/4" lagging	6.5	11.125	30
SAD6TE36SB-2PL4	2	PULSES	1/4" lagging	6.5	13.250	36
SAD6TE42SB-2PL4	2	PULSES	1/4" lagging	6.5	15.438	42
SAD6TE48SB-2PL4	2	PULSES	1/4" lagging	6.5	17.625	48
SAD6TE54SB-2PL4	2	PULSES	1/4" lagging	6.5	19.750	54
SAD6TE60SB-2PL4	2	PULSES	1/4" lagging	6.5	21.750	60

SAD6TE24SB-6PL4	6	PULSES	1/4" lagging	6.5	8.938	24
SAD6TE30SB-6PL4	6	PULSES	1/4" lagging	6.5	11.125	30
SAD6TE36SB-6PL4	6	PULSES	1/4" lagging	6.5	13.250	36
SAD6TE42SB-6PL4	6	PULSES	1/4" lagging	6.5	15.438	42
SAD6TE48SB-6PL4	6	PULSES	1/4" lagging	6.5	17.625	48
SAD6TE54SB-6PL4	6	PULSES	1/4" lagging	6.5	19.750	54
SAD6TE60SB-6PL4	6	PULSES	1/4" lagging	6.5	21.750	60

FLAT RETURN SMART ROLL PART NUMBERS

PART NUMBER	PULSES PER REVOLUTION		LAGGING THICKNESS	ROLL DIA	ROLL LENGTH	BELT WIDTH
SAD5FL24SB-1P	1	PULSE	no lagging	5.0	27.375	24
SAD5FL30SB-1P	1	PULSE	no lagging	5.0	33.375	30
SAD5FL36SB-1P	1	PULSE	no lagging	5.0	39.375	36
SAD5FL42SB-1P	1	PULSE	no lagging	5.0	45.375	42
SAD5FL48SB-1P	1	PULSE	no lagging	5.0	51.375	48
SAD5FL54SB-1P	1	PULSE	no lagging	5.0	57.375	54
SAD5FL60SB-1P	1	PULSE	no lagging	5.0	63.375	60

SAD5FL24SB-2P	2	PULSES	no lagging	5.0	27.375	24
SAD5FL30SB-2P	2	PULSES	no lagging	5.0	33.375	30
SAD5FL36SB-2P	2	PULSES	no lagging	5.0	39.375	36
SAD5FL42SB-2P	2	PULSES	no lagging	5.0	45.375	42
SAD5FL48SB-2P	2	PULSES	no lagging	5.0	51.375	48
SAD5FL54SB-2P	2	PULSES	no lagging	5.0	57.375	54
SAD5FL60SB-2P	2	PULSES	no lagging	5.0	63.375	60

SAD5FL24SB-6P	6	PULSES	no lagging	5.0	27.375	24
SAD5FL30SB-6P	6	PULSES	no lagging	5.0	33.375	30
SAD5FL36SB-6P	6	PULSES	no lagging	5.0	39.375	36
SAD5FL42SB-6P	6	PULSES	no lagging	5.0	45.375	42
SAD5FL48SB-6P	6	PULSES	no lagging	5.0	51.375	48
SAD5FL54SB-6P	6	PULSES	no lagging	5.0	57.375	54
SAD5FL60SB-6P	6	PULSES	no lagging	5.0	63.375	60

SAD5FL24SB-1PL4	1	PULSE	1/4" lagging	5.5	27.375	24
SAD5FL30SB-1PL4	1	PULSE	1/4" lagging	5.5	33.375	30
SAD5FL36SB-1PL4	1	PULSE	1/4" lagging	5.5	39.375	36
SAD5FL42SB-1PL4	1	PULSE	1/4" lagging	5.5	45.375	42
SAD5FL48SB-1PL4	1	PULSE	1/4" lagging	5.5	51.375	48
SAD5FL54SB-1PL4	1	PULSE	1/4" lagging	5.5	57.375	54
SAD5FL60SB-1PL4	1	PULSE	1/4" lagging	5.5	63.375	60

SAD5FL24SB-2PL4	2	PULSES	1/4" lagging	5.5	27.375	24
SAD5FL30SB-2PL4	2	PULSES	1/4" lagging	5.5	33.375	30
SAD5FL36SB-2PL4	2	PULSES	1/4" lagging	5.5	39.375	36
SAD5FL42SB-2PL4	2	PULSES	1/4" lagging	5.5	45.375	42
SAD5FL48SB-2PL4	2	PULSES	1/4" lagging	5.5	51.375	48
SAD5FL54SB-2PL4	2	PULSES	1/4" lagging	5.5	57.375	54
SAD5FL60SB-2PL4	2	PULSES	1/4" lagging	5.5	63.375	60

SAD5FL24SB-6PL4	6	PULSES	1/4" lagging	5.5	27.375	24
SAD5FL30SB-6PL4	6	PULSES	1/4" lagging	5.5	33.375	30
SAD5FL36SB-6PL4	6	PULSES	1/4" lagging	5.5	39.375	36
SAD5FL42SB-6PL4	6	PULSES	1/4" lagging	5.5	45.375	42
SAD5FL48SB-6PL4	6	PULSES	1/4" lagging	5.5	51.375	48
SAD5FL54SB-6PL4	6	PULSES	1/4" lagging	5.5	57.375	54
SAD5FL60SB-6PL4	6	PULSES	1/4" lagging	5.5	63.375	60

PART NUMBER	PULSES PER REVOLUTION		LAGGING THICKNESS	ROLL DIA	ROLL LENGTH	BELT WIDTH
SAD6FL24SB-1P	1	PULSE	no lagging	6.0	27.375	24
SAD6FL30SB-1P	1	PULSE	no lagging	6.0	33.375	30
SAD6FL36SB-1P	1	PULSE	no lagging	6.0	39.375	36
SAD6FL42SB-1P	1	PULSE	no lagging	6.0	45.375	42
SAD6FL48SB-1P	1	PULSE	no lagging	6.0	51.375	48
SAD6FL54SB-1P	1	PULSE	no lagging	6.0	57.375	54
SAD6FL60SB-1P	1	PULSE	no lagging	6.0	63.375	60

SAD6FL24SB-2P	2	PULSES	no lagging	6.0	27.375	24
SAD6FL30SB-2P	2	PULSES	no lagging	6.0	33.375	30
SAD6FL36SB-2P	2	PULSES	no lagging	6.0	39.375	36
SAD6FL42SB-2P	2	PULSES	no lagging	6.0	45.375	42
SAD6FL48SB-2P	2	PULSES	no lagging	6.0	51.375	48
SAD6FL54SB-2P	2	PULSES	no lagging	6.0	57.375	54
SAD6FL60SB-2P	2	PULSES	no lagging	6.0	63.375	60

SAD6FL24SB-6P	6	PULSES	no lagging	6.0	27.375	24
SAD6FL30SB-6P	6	PULSES	no lagging	6.0	33.375	30
SAD6FL36SB-6P	6	PULSES	no lagging	6.0	39.375	36
SAD6FL42SB-6P	6	PULSES	no lagging	6.0	45.375	42
SAD6FL48SB-6P	6	PULSES	no lagging	6.0	51.375	48
SAD6FL54SB-6P	6	PULSES	no lagging	6.0	57.375	54
SAD6FL60SB-6P	6	PULSES	no lagging	6.0	63.375	60

SAD6FL24SB-1PL4	1	PULSE	1/4" lagging	6.5	27.375	24
SAD6FL30SB-1PL4	1	PULSE	1/4" lagging	6.5	33.375	30
SAD6FL36SB-1PL4	1	PULSE	1/4" lagging	6.5	39.375	36
SAD6FL42SB-1PL4	1	PULSE	1/4" lagging	6.5	45.375	42
SAD6FL48SB-1PL4	1	PULSE	1/4" lagging	6.5	51.375	48
SAD6FL54SB-1PL4	1	PULSE	1/4" lagging	6.5	57.375	54
SAD6FL60SB-1PL4	1	PULSE	1/4" lagging	6.5	63.375	60

SAD6FL24SB-2PL4	2	PULSES	1/4" lagging	6.5	27.375	24
SAD6FL30SB-2PL4	2	PULSES	1/4" lagging	6.5	33.375	30
SAD6FL36SB-2PL4	2	PULSES	1/4" lagging	6.5	39.375	36
SAD6FL42SB-2PL4	2	PULSES	1/4" lagging	6.5	45.375	42
SAD6FL48SB-2PL4	2	PULSES	1/4" lagging	6.5	51.375	48
SAD6FL54SB-2PL4	2	PULSES	1/4" lagging	6.5	57.375	54
SAD6FL60SB-2PL4	2	PULSES	1/4" lagging	6.5	63.375	60

SAD6FL24SB-6PL4	6	PULSES	1/4" lagging	6.5	27.375	24
SAD6FL30SB-6PL4	6	PULSES	1/4" lagging	6.5	33.375	30
SAD6FL36SB-6PL4	6	PULSES	1/4" lagging	6.5	39.375	36
SAD6FL42SB-6PL4	6	PULSES	1/4" lagging	6.5	45.375	42
SAD6FL48SB-6PL4	6	PULSES	1/4" lagging	6.5	51.375	48
SAD6FL54SB-6PL4	6	PULSES	1/4" lagging	6.5	57.375	54
SAD6FL60SB-6PL4	6	PULSES	1/4" lagging	6.5	63.375	60



CORPORATE OFFICE • P.O. Box 287 • Pella, IA 50219
800.247.1228 • 641.628.3115 • 641.628.3658 FAX