



KEYLESS LOCKING ASSEMBLIES FOR RBM

PPI RBM hubs are manufactured for all pulley types. RBM hubs are suitable with B115, RFN 7009, or MAV 1008 keyless locking assemblies.

Locking assemblies are supplied ready for installation. If the unit should be dismantled, make sure that in addition to lined-up slits in all collars, near and far-side clamp collars are not reversed. They are assembled correctly if there are no holes or threads behind taps in clamp collar item ② and no threads behind taps in center collar item ③. The torque capacity of these devices is based on a coefficient of friction of 0.12 for lightly oiled screws, tapers, shaft and hub contact areas. Therefore, it is important NOT to use Molybdenum Disulfide in any locking assembly installation. For example, Molykote, Never-Seeze or similar lubricants.

INSTALLATION

1. Make sure that locking screws, rings, shaft and hub contact surfaces are clean and lightly oiled and that all collar slits are aligned.
2. Loosen all screws ① a minimum of two turns and transfer at least two screws to push-off threads in clamp collar item ② and center collar item ③ in order to disengage tapers for easy installation of locking assembly.
3. After installation of locking assembly, relocate locking screws used for separation of collars.
4. Hand tighten connection and assure that collar item ② is parallel with face of part to be attached to the shaft.
5. Use torque wrench and set it approximately 5% higher than specified tightening torque (Ma). Torque screws ① in a crosswise pattern, using only 1/4 turns for several passes until 1/4 turns can no longer be achieved.
6. Apply over torque technique from step 5 for 1 to 2 more passes. This is required to compensate for a system-related relaxation of locking screws since tightening of a given screw will always relax adjacent screws.
7. Reset torque wrench to specified torque (Ma) and check all locking screws. No screw should turn at this point, otherwise repeat step 6 for 1 or 2 more passes. It is not necessary to re-check tightening torque after equipment has been in operation.

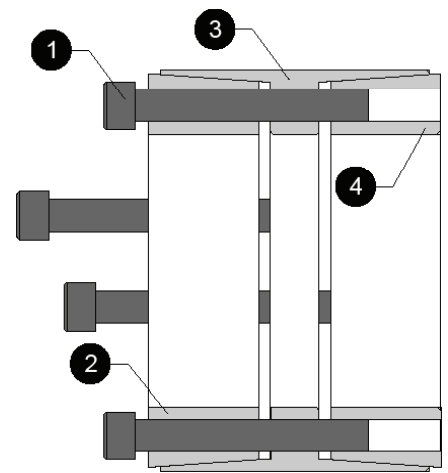

For installation subjected to extreme corrosion, the slits in clamp collars item ② and ④ as well as in center collar item ③ should be sealed with a suitable caulking compound or equivalent. Likewise, push-off threads should also be protected from corrosion.

REMOVAL

Prior to initiating the following removal procedure, check to ensure that no torque or thrust loads are acting on the locking assembly, shaft or any mounted components.

It is important that the user ensure that ends of locking screws **1** used for removal are ground flat and slightly chamfered to prevent damage to screws and collar threads during push-off. Screws with ground flat and chamfered end are not supplied. The user has to take charge of grinding the end of the screws.

1. Check to ensure that axial movement of collars, which is necessary for release of connection, is not restricted. Likewise, ensure that push-off threads are in good conditions.
2. Remove all locking screws **1** and transfer some into all push-off threads in clamp collar item **2**.
3. Release collar item **2** by tightening all push-off screws in a crosswise pattern, not exceeding 1/4 turns for several passes.
4. Transfer locking screws used for dismounting of clamp collar item **2** into all push-off threads in center collar item **3**. Release clamp collar item **4** by repeating procedure outlined in step 3.

Bolt sizes and torques for keyless locking assemblies used in PPI RBM hubs are listed in the table below:

Bolt Size	Bolt Torque (Ma)		Hex Size (mm)	RBM
	(ft-lbs)	(N-m)		
M10	60	81	8	70-90
M12	105	142	10	100-160
M14	166	225	12	170-200
M16	257	348	14	220-260
M20	500	678	17	280-340
M22	675	915	17	360-600

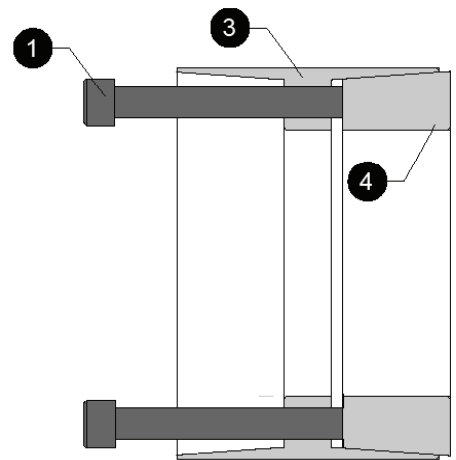
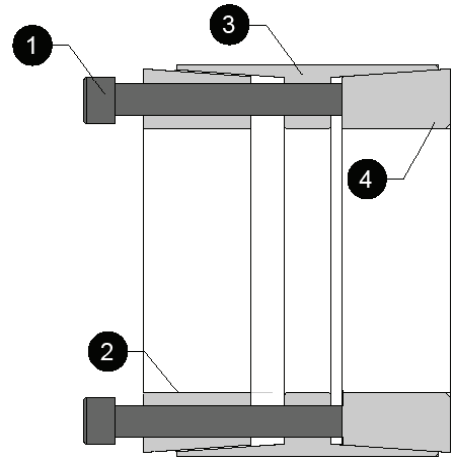

CORPORATE OFFICE • P.O. Box 287 • Pella, IA 50219
800.247.1228 • 641.628.3115 • 641.628.3658 FAX