



# PHD/PHYD TAKE-UP FRAME

## INSTALLATION

It is recommended to use a paintbrush to coat the threaded rod with grease before installation. This will lubricate the rod, reducing friction and provide protection against corrosion. It is suggested that one person turn the rod, as another person applies the grease to the rod.

Hydraulic Frame part number begins with PHYD and only includes the frame. It is set up ready to receive the hydraulic components which are sold separately. For a complete breakdown of part numbers, see page 6 of the TUF catalog. The 4 basic parts of a hydraulic assisted take up frame are illustrated on page 2.

## CORROSION

While some customers request stainless steel rods and nuts for their application to eliminate corrosion, PPI has determined through years of experience, that this is not recommended. Instead, PPI suggests one of the following to deter corrosion.

1. Use mild steel rod and nuts and use grease (standard)
2. Use stainless steel rod with mild steel nuts and grease.
3. Use stainless steel rod with brass nuts and grease.

While stainless steel will not corrode, it can gall. If both the rod and nut are stainless steel and galling starts, it will continue. When combined with the work hardening properties of stainless steel it will seize and the two parts will lock together. Having only one stainless steel will result in better service over the years. The fixed nuts, which are pinned to the rod, are always mild steel.

## OPERATION

Some pillow block bearings used with take up frames are self-aligning but many are not. The ones that are self-aligning have limits of 1 to 3 degrees. Therefore, both take-up frames should be tightened at the same time. It is recommended not to turn one screw more than one turn ahead of the other. If one person is tightening both frames, they should turn one screw, then the other, until proper tension is achieved.

## TRACKING THE BELT

While take-up frames are not designed for tracking purposes. They are used to adjust the pulley positioning in regards to squaring with the belt. To do this, one frame will need to be tightened while loosening the other frame equally. The frames already have proper tensioning; therefore you are adjusting the pulley to run square to the belt.

## HYDRAULIC FRAMES

PHYD frames are designed for series 2HD Head Trunion mount cylinders – NFPA #MT1. The design was set up for a double action cylinder with lip seals. If the system is set up this way, the cylinder may be powered with a hydraulic pump with a five gallon reservoir that can achieve a pressure of 2500 psi. Please refer to the TUF catalog for sizes and dimensions of PHYD frames and the rod and cylinder bore that these frames are built to handle.

If the order does not specify, the frame will be set up for a pull application which is a single stop nut on the screw and on the side opposite the cylinder. For the frame to be used in push mode, the stop nut will need to be between the cylinder and the saddle.

To switch the frame from pull to push mode or vice versa, the user will need to remove the pin from the nut on the end of the frame nearest to the stop nut. Then turn the frame over and slide the rod out as it is turned until the stop nut is loose from the rod. Pull the rod out and slide it in from the other end of the frame and through the square tube on the saddle and into the stop nut. Turn the rod into the stop nut until the rod can stick through the end of the nut to be re-attached. Re-install the end nut, making sure that the hole in the nut lines up with the hole in the threaded rod. If it doesn't, remove the nut and turn it around and try it again. Drive the pin into the nut and through the threaded rod.

## OPERATION OF PHYD - HYDRAULIC FRAMES

To tighten or loosen the belt, first run the hydraulic cylinder up to pressure to release the load on the take-up frame screw. This should be done to both cylinders at the same time. Once the load is off of the screw, turn the screws to increase the room between the stop nut and the saddle.

Use the cylinder to adjust the pressure. Either up or down, making sure that there is sufficient clearance between the stop nut and the saddle for a full range of motion. Once the correct position of the saddle or cylinder pressure has been achieved, then turn the screw to bring the stop nut up to hold the saddle in place. Slowly release the pressure in the cylinder.

## HYDRAULIC ASSISTED TAKE-UP IN PULL MODE

Hydraulic cylinder movement is used to move the pulley. The threaded rod is rotated to engage STOP NUT and lock the pulley from movement.

### Operations To Increase Belt Tension

1. Apply hydraulic pressure to the rod end of the cylinder to cause take-up pulley movement until desired belt tension is achieved. The pressure gage on the cylinder can be used to establish belt tension from the cylinder area.  
Pressure x Area = Force

### Key:

- Yellow HYDHPUMP (hand pump - complete part#)
- Blue HYD (cylinder, example HYD3217x24)
- Gray PHYD (frame, example PHYD500-3217x24)
- Black HOSE (kits, MHOSE, LHOSE, or XHOSE)
- Dark Other components (Pulley, Bearings & Belt)

2. When finished adjusting tension, rotate travel rod end nut by moving the stop nuts toward and against the saddle until resistance is felt. Hydraulic pressure can now be released (the STOP NUT is on the end of the saddle opposite the cylinder when using Take-up Frame in PULL MODE. The STOPNUT will be on the end of the saddle next to the cylinder when in PUSHMODE).

3. If further movement is needed, repeat step 1 & 2 as needed.

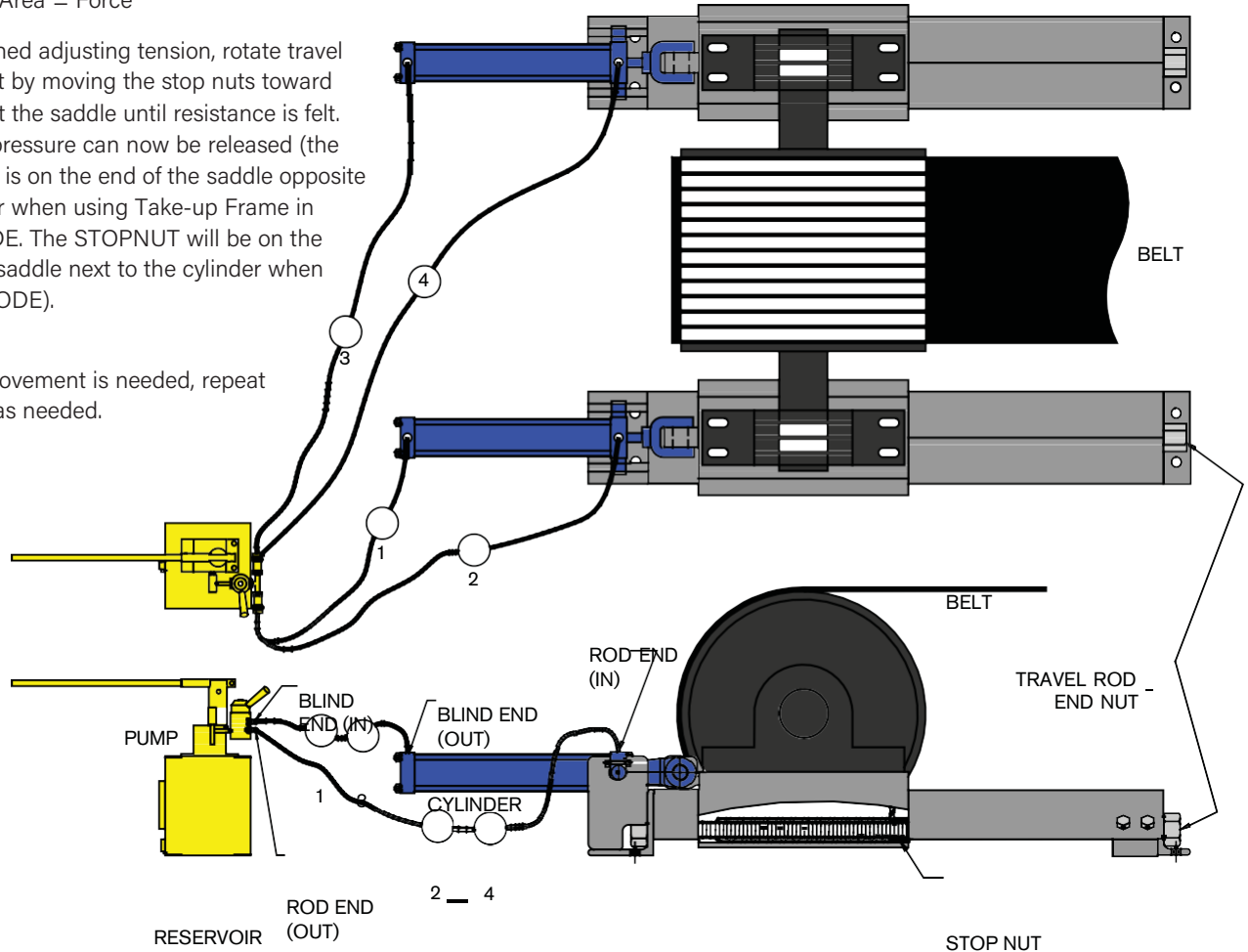

### Operations To Decrease Belt Tension

1. Apply hydraulic pressure to the rod end of cylinder.
2. Rotate the travel rod end nuts, moving the STOP NUTS away from the saddle. This will allow the saddle to move in the desired direction. (The STOP NUT is on the end of the saddle opposite the cylinder when using Take-up Frame in PULL MODE. The STOPNUT will be on the end of the saddle next to the cylinder when in PUSHMODE)
3. Actuate cylinder applying hydraulic pressure to the cylinder end of the cylinder (or allow pressure to bleed off of the rod end of the cylinder). This will cause Take-up pulley movement until desired belt tension is achieved.
4. If further movement is needed, repeat step 1 through 3 as needed.
5. When finished adjusting tension, rotate travel rod end nuts in opposite direction to step 2 until resistance is felt. Hydraulic pressure can now be released.

### NOTES:

1. Hydraulic Take-Up Frame and cylinder ship unassembled.
2. The Pump Kit comes with a 5 gallon reservoir, pressure gauge, oil level gauge, and valves.
3. The Hose Kit comes with 3/8" hoses, fittings, and adapters.

CYLINDERS ARE SHOWN IN "PULLING" CONFIGURATION WITH STOP NUT POSITIONED TO PREVENT PULLEY MOVEMENT.

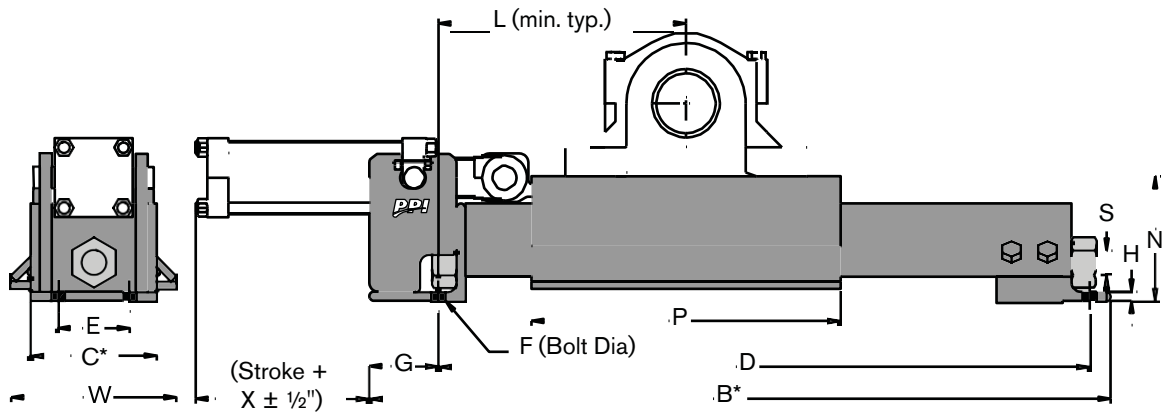

All PHYD frames are setup for pull applications at the factory, unless otherwise specified.

PHYD Frames are designed to be used with 4-bolt Pillow Blocks.

PHYD Frames are designed for series 2HD Head Trunion mount cylinders - NFPA #MT1

Precision standard Hydraulic Cylinders have lips seals, SAE ports, and Breather(s).

NOTE: X will vary depending upon Cylinder Manufacturer and whether the Take Up is being used in pull or push application.

Part Number	Max Pillow Block Length (in)	Cylinder		Area		Max Force		Max Pressure		Max Push Stroke* (in)	SAE Port Size	PHYD Dim		
		Bore (in)	Rod (in)	Pull (sq in)	Push (sq in)	Pull (lb)	Push (lb)	Pull (psi)	Push (psi)			G	X ± 1/2"	
PHYD300-2010	14 1/4	2	1	2.357	3.142	5,800	6,000	2,461	1,910	24	8 or 10	3 3/8	2 3/8	
PHYD308-2010	16	2	1	2.357	3.142	5,800	8,000	2,461	2,546	18	8 or 10	3 3/8	2 3/8	
PHYD308-2513		2 1/2	1 3/8	3.424	4.909	8,500	9,000	2,482	1,833	30		4 5/16	2 9/16	
PHYD400-2513	20	2 1/2	1 3/8	3.424	4.909	8,500	12,000	2,482	2,444	30	8 or 10	4 5/16	2 9/16	
PHYD400-3213		3 1/4	1 3/8	6.811	8.296	12,000	12,000	1,762	1,446			12	4 5/8	3 1/4
PHYD500-3217	23 1/2	3 1/4	1 3/4	5.891	8.296	14,500	18,000	2,461	2,170	30	12	5 7/8	3 1/4	
PHYD500-4017		4	1 3/4	10.161	12.566	18,000	18,000	1,771	1,432			3 1/2		
PHYD600-4020	25 3/4	4	2	9.424	12.566	23,000	30,000	2,441	2,387	30	12	5 3/4	2 1/16	
PHYD600-5020		5	2	16.493	19.635	30,000	30,000	1,819	1,528			2 3/4		
PHYD800-5020	32	5	2	16.493	19.635	36,000	43,000	2,183	2,190	30	12	5 3/4	2 7/16	
PHYD800-6025		6	2 1/2	23.365	28.274	50,000	50,000	2,140	1,768			16	3 9/16	
PHYD1000-6025	36	6	2 1/2	23.365	28.274	50,000	62,000	2,140	2,193	30	16	6 3/4	3 1/16	
PHYD1000-7030		7	3	31.416	38.485	70,000	85,000	2,228	2,209				20	4
PHYD1000-8035		8	3 1/2	40.644	50.265	90,000	90,000	2,214	1,791				24	5 1/8

\*Cylinders beyond push max stroke, MAY have to be adjusted for the application (which will increase X).

Consult Precision Engineers for Push Applications beyond the Max Push Stroke\*

**Hydraulic Oil Recommendations  
for HYDH PUMP (Hand Pumps)**

Typical test data

Density..... 0.8375  
 Flash..... 182° C  
 Viscosity at 40° C..... 15.8 cSt  
 Viscosity at 100° C..... 4.07 cST  
 Average Viscosity Index ..... 168  
 Pour ..... Minus 54° C  
 Rust and Oxidation Inhibited  
 Incorporated Foam Depressant

Approved Sources:

Mobile DTE 10 Excel 15  
 Lubriplate "Special low pour hydraulic oil" #76762 (pour -75° F)

Emergency Sources:

SAE 5 Motor Oil – (Viscosity 60 S.U.S.)  
 Automatic transmission fluid

PHYD KEEPER PLATE

Frame	Keeper Plate	Bolts
PHYD300-600	56402	NA
PHYD800-1000	57170	500391

- Two keeper plates are required for each cylinder to hold the cylinder down in the trunion blocks.
- For the PHYD 800 & 1000, two bolts are required to bolt the keeper plate to the trunion block. These bolts are 1/2" - 13UNC x 1 1/2 long. Part # 500391
- For the PHYD 300 thru 600, bolts are not required because the keeper plate has tabs that bend to hold it in place.

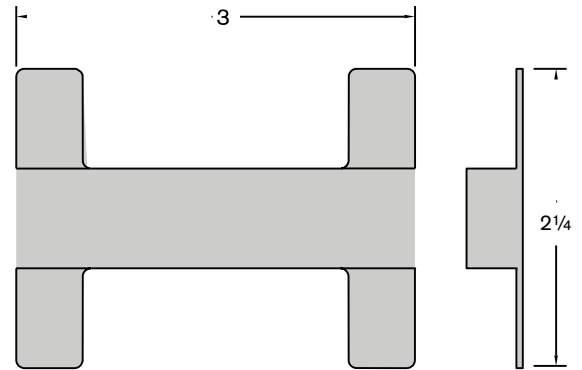

## Hydraulic Hand Pump & Hose Kits

### HYDHPUMP (75 LB)

QTY	DESCRIPTION
1	Hand Pump
1	Reservoir (5 GAL) with Oil Level Gage, Drain & Cap
1	Directional Valve
2	Tee Connector
2	Quick Disconnect Socket
2	Quick Disconnect Plug

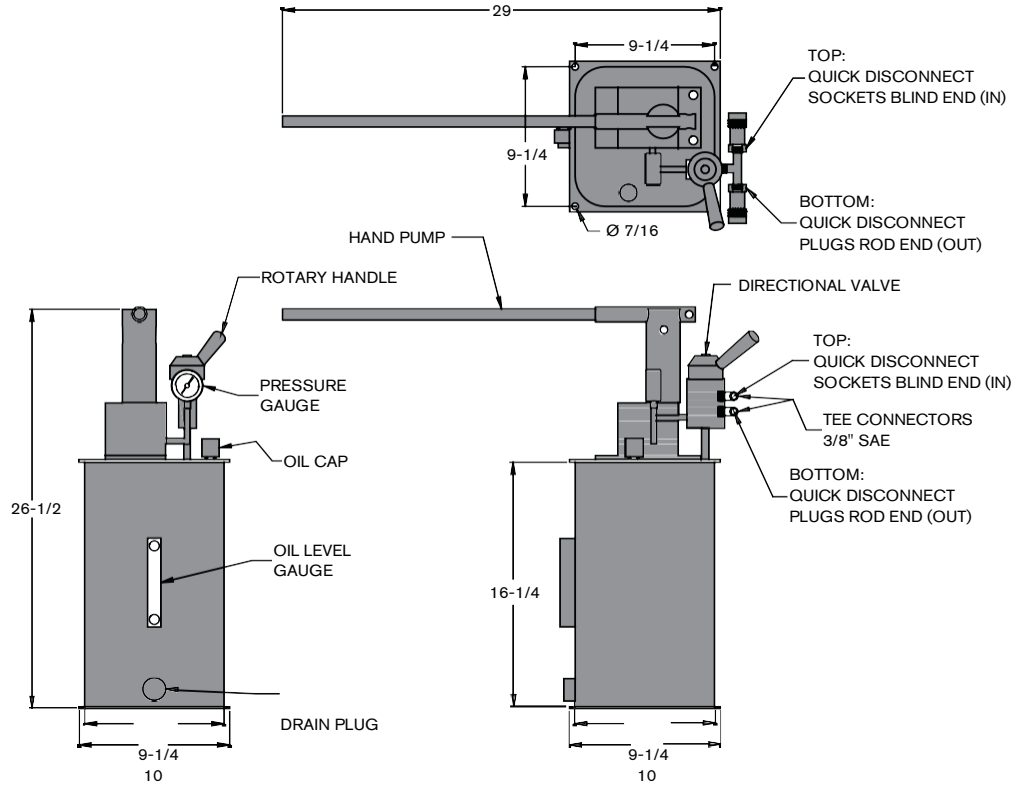

### HOSE KITS

### SAE PORT SIZES (REFERENCE)

QTY	DESCRIPTION	
1	3 ft 3/8" Diameter hose	
1	6 ft 3/8" Diameter hose	
1	12 ft 3/8" Diameter hose	
1	15 ft 3/8" Diameter hose	
2	Quick Disconnect Socket	
2	Quick Disconnect Plug	
All Hose Kits Include the Above Plus		
PART #	DESCRIPTION	Weight
MHOSE	#10 to #8 & #12 to #8 Port Adapters	30 lbs
LHOSE	#16 to #8 & #20 to #8 Port Adapters	32 lbs
XHOSE	#16 to #8 & #24 to #16 Port Adapters	35 lbs

SAE Size	Inch Size	Thread	Male Thread OD (in)	Female Thread ID (in)	Male	Female Thread ID (mm)
2	1/8	5/16-24	0.31	0.27	7.9	6.9
3	3/16	3/8-24	0.38	0.34	9.6	8.6
4	1/4	7/16-20	0.44	0.39	11.2	9.9
5	5/16	1/2-20	0.50	0.45	12.7	11.4
6	3/8	5/8-18	0.56	0.51	14.2	12.9
8	1/2	3/4-16	0.75	0.67	19	17
10	5/8	7/8-14	0.88	0.80	22.3	20.3
12	3/4	1 1/16-12	1.06	0.98	26.9	24.9
14	7/8	1 3/16-12	1.18	1.09	30	27.7
16	1	1 5/16-12	1.31	1.22	33.3	31
20	1 1/4	1 5/8-12	1.63	1.54	41.4	39.1
24	1 1/2	1 7/8-12	1.88	1.79	47.7	45.5
32	2	2 1/2-12	2.50	2.41	63.5	61.2

## PHYD Cylinders

HYD Cylinders are available with boots to protect the rod. To specify a cylinder with a boot, add a B to the end of the part #, example: HYD3217x12B

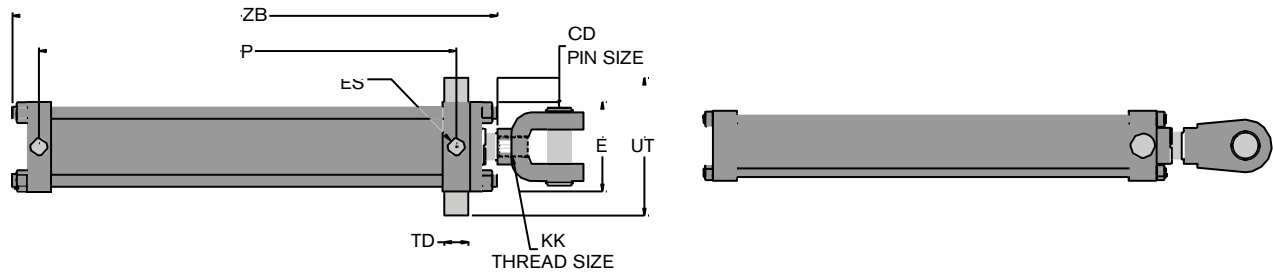

Part Number	Bore Diameter	Rod Diameter	Stroke	P	ZB	CD	KK	E	TD	UT	ES	Approximate Weight
HYD2010X12	2	1	12	14 7/8	18 11/16	3/4	3/4-16	3	1 3/8	5 3/4	#8 or #10 SAE MHOSE KIT	20
HYD2010X18			18	20 7/8	24 11/16							25
HYD2010X24			24	26 7/8	30 11/16							30
HYD2010X30			30	32 7/8	36 11/16							35
HYD2010X36			36	38 7/8	42 11/16							40
HYD2010X48			48	50 7/8	54 11/16							50
HYD2513X12	2 1/2	1 3/8	12	15	19 1/16	1	1-14	3 1/2	1 3/8	6 1/4	#8 or #10 SAE MHOSE KIT	35
HYD2513X18			18	21	25 1/16							43
HYD2513X24			24	27	31 1/16							50
HYD2513X30			30	33	37 1/16							60
HYD2513X36			36	39	43 1/16							68
HYD2513X48			48	51	55 1/16							82
HYD3213X12	3 1/4	1 3/8	12	15 1/2	19 31/32	1	1-14	4 1/2	1 3/4	8	#12 SAE MHOSE KIT	50
HYD3213X18			18	21 1/2	25 31/32							60
HYD3213X24			24	27 1/2	31 31/32							70
HYD3213X30			30	33 1/2	37 31/32							80
HYD3213X36			36	39 1/2	43 31/32							90
HYD3213X48			48	51 1/2	55 31/32							110
HYD3217X12	3 1/4	1 3/4	12	15 1/2	20 3/16	1 3/8	1 1/4-12	4 1/2	1 3/4	8	#12 SAE MHOSE KIT	60
HYD3217X18			18	21 1/2	26 3/16							70
HYD3217X24			24	27 1/2	32 3/16							80
HYD3217X30			30	33 1/2	38 3/16							90
HYD3217X36			36	39 1/2	44 3/16							110
HYD3217X48			48	51 1/2	56 3/16							130
HYD4017X12	4	1 3/4	12	15 3/4	20 7/16	1 3/8	1 1/4-12	5	1 3/4	8 1/2	#12 SAE MHOSE KIT	85
HYD4017X18			18	21 3/4	26 7/16							105
HYD4017X24			24	27 3/4	32 7/16							125
HYD4017X30			30	33 3/4	38 7/16							145
HYD4017X36			36	39 3/4	44 7/16							160
HYD4017X48			48	51 3/4	56 7/16							190
HYD4020X12	4	2	12	15 3/4	20 9/16	1 3/4	1 1/2-12	5	1 3/4	8 1/2	#12 SAE MHOSE KIT	90
HYD4020X18			18	21 3/4	26 9/16							110
HYD4020X24			24	27 3/4	32 9/16							130
HYD4020X30			30	33 3/4	38 9/16							150
HYD4020X36			36	39 3/4	44 9/16							170
HYD4020X48			48	51 3/4	56 9/16							205

**PHYD Cylinders, cont.**

Part Number	Bore Diameter	Rod Diameter	Stroke	P	ZB	CD	KK	E	TD	UT	ES	Approximate Weight
HYD5020X12	5	2	12	16 1/4	21 5/16	1 3/4	1 1/2-12	6 1/2	1 3/4	10	#12 SAE MHOSE KIT	130
HYD5020X18			18	22 1/4	27 5/16							160
HYD5020X24			24	28 1/4	33 5/16							190
HYD5020X30			30	34 1/4	39 5/16							210
HYD5020X36			36	40 1/4	45 5/16							240
HYD5020X48			48	52 1/4	57 5/16							300
HYD6025X12	6	2 1/2	12	16 7/8	22 3/4	2	1 7/8-12	7 1/2	2	11 1/2	#16 SAE LHOSE KIT	150
HYD6025X18			18	22 7/8	28 3/4							180
HYD6025X24			24	28 7/8	34 3/4							210
HYD6025X30			30	34 7/8	40 3/4							240
HYD6025X36			36	40 7/8	46 3/4							260
HYD6025X48			48	52 7/8	58 3/4							320
HYD7030X12	7	3	12	17	25 1/4	2 1/2	2 1/4-12	8 1/2	2 1/2	13 1/2	#20 SAE LHOSE KIT	175
HYD7030X18			18	23	31 1/4							205
HYD7030X24			24	29	37 1/4							235
HYD7030X30			30	35	43 1/4							265
HYD7030X36			36	41	49 1/4							285
HYD7030X48			48	53	61 1/4							345
HYD8035X12	8	3 1/2	12	18 1/8	25 1/4	3	2 1/2-12	9 1/2	3	15 1/2	#24 SAE XHOSE KIT	200
HYD8035X18			18	24 1/8	31 1/4							225
HYD8035X24			24	30 1/8	37 1/4							250
HYD8035X30			30	36 1/8	43 1/4							275
HYD8035X36			36	42 1/8	49 1/4							300
HYD8035X48			48	54 1/8	61 1/4							350



**CORPORATE OFFICE** • P.O. Box 287 • Pella, IA  
50219800.247.1228 • 641.628.3115 • 641.628.3658 FAX