

T1: _____
 T2: _____
 MOTOR HP: _____
 BELT SPEED: _____
 GEARBOX MODEL: _____

DATA TAKEN FROM VIEWING PERSPECTIVE "A"

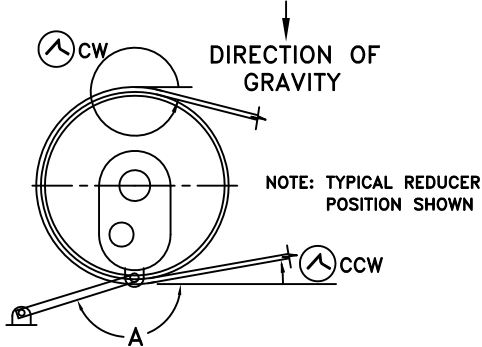

BELT ANGLE COMING OFF PULLEY IN CW DIRECTION (⌚ CW): _____
 BELT ANGLE COMING OFF PULLEY IN CCW DIRECTION (⌚ CCW): _____
 ROTATION (CW, CCW, BOTH): _____
 TORQUE ARM ANGLE (A) FROM HORIZONTAL: _____

DRIVE ASSEMBLY DATA

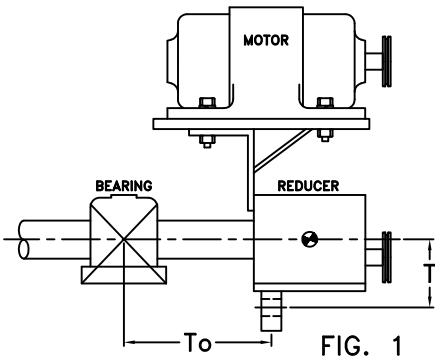

FIG. 1
 TORQUE ARM DISTANCE (T):
 TORQUE ARM/BEARING CENTER DISTANCE (To):
 MOTOR WEIGHT (INCLUDING BRACKETS):
 REDUCER WEIGHT:

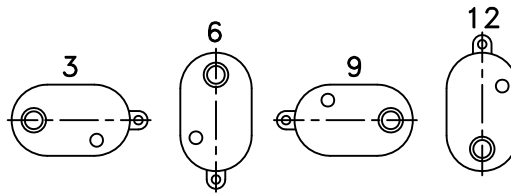

FIG. 2

FIG. 2
 DRIVE AT 3,6,9, OR 12 O'CLOCK POSITION

ASSEMBLY SIDE "A"	ASSEMBLY SIDE "B"
_____	_____
_____	_____
_____	_____

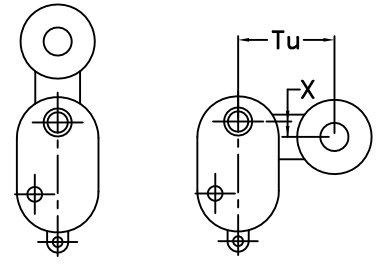

FIG. 3A FIG. 3B

FIG. 3
 IS MOTOR ATTACHED PER FIG. 3(A, B, OR C)
 IF 3B OR 3C, MOTOR OFFSET (X)
 MOTOR SHAFT DISTANCE (Tu) (3B & 3C ONLY):

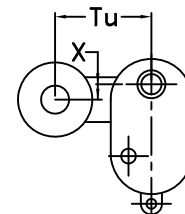

FIG. 3C