

*WE KEEP IT MOVING®*

ENGINEERING & DIMENSIONS

**MARCO® IDLERS**

# MARCO® 20° AND 35° TROUGHING IDLERS

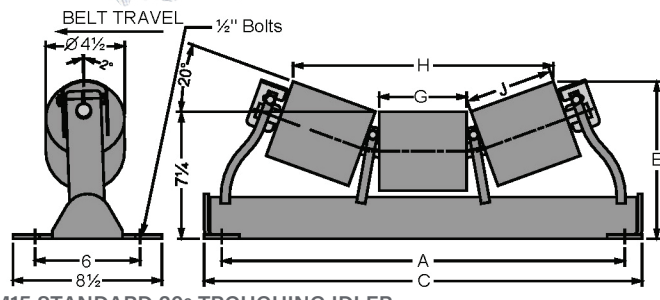

M15 STANDARD 20° TROUGHING IDLER

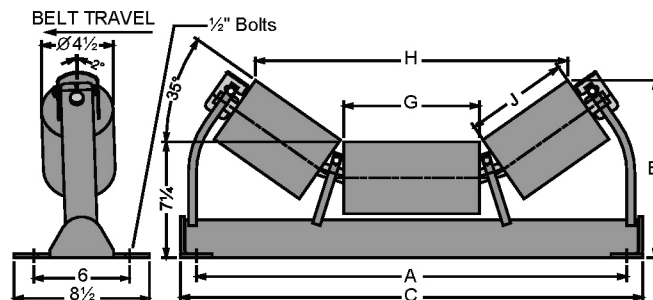

PART NUMBER	BELT WIDTH	A	C	E	G	H	J	WEIGHT
M15-14	14	23	25	9	5	14 7/8	5	26
M15-16	16	25	27	9	6 1/2	16 3/8	5	29
M15-18	18	27	29	9 1/2	6 1/2	19 1/4	6 1/2	32
M15-20	20	29	31	9 1/2	8 1/2	21 1/4	6 1/2	33
M15-24	24	33	35	10 1/4	8 1/2	25	8 1/2	37
M15-30	30	39	41	10 7/8	10 1/2	30 3/4	10 1/2	41
M15-36	36	45	47	11 5/8	12 1/2	36 1/2	12 1/2	45
M15-42	42	51	53	11 5/8	18 1/2	42 1/2	12 1/2	47

M15P PICKING IDLER 20° TROUGHING IDLER (LONG CENTER ROLL)

PART NUMBER	BELT WIDTH	A	C	E	G	H	J	WEIGHT
M15P-24	24	33	35	9 1/2	12 1/2	25 1/4	6 1/2	37
M15P-30	30	39	41	9 1/2	18 1/2	31 1/4	6 1/2	41
M15P-36	36	45	47	9 1/2	24 1/2	37 1/4	6 1/2	45
M15P-42	42	51	53	9 1/2	30 1/2	43 1/4	6 1/2	49

MA15 NARROW BASE 20° TROUGHING IDLER STYLE A

PART NUMBER	BELT WIDTH	A	C	E	G	H	J	WEIGHT
MA15-14	14	20 3/4	22 3/4	9	5	14 7/8	5	25
MA15-16	16	20 3/4	22 3/4	9	6 1/2	16 3/8	5	28
MA15-18	18	24 3/4	26 3/4	9 1/2	6 1/2	19 1/4	6 1/2	31
MA15-20	20	24 3/4	26 3/4	9 1/2	8 1/2	21 1/4	6 1/2	32
MA15-24	24	28 3/4	30 3/4	10 1/4	8 1/2	25	8 1/2	36
MA15-30	30	39	41	10 7/8	10 1/2	30 3/4	10 1/2	40
MA15-36	36	42 1/2	44 1/2	11 5/8	12 1/2	36 1/2	12 1/2	45
MA15-42	42	50 1/2	52 1/2	11 5/8	18 1/2	42 1/2	12 1/2	48

M1534 EQUAL 35° TROUGHING IDLER

PART NUMBER	BELT WIDTH	A	C	E	G	H	J	WEIGHT
M1534-18	18	27	29	11 1/8	6 1/2	17 1/2	6 1/2	34
M1534-20	20	29	31	11 1/8	8 1/2	19 1/2	6 1/2	36
M1534-24	24	33	35	12 1/4	8 1/2	22 3/4	8 1/2	38
M1534-30	30	39	41	13 3/8	10 1/2	28 1/4	10 1/2	45
M1534-36	36	45	47	14 1/2	12 1/2	33 3/8	12 1/2	53
M1534-42	42	51	53	15 5/8	14 1/2	38 1/2	14 1/2	61

M1535 PICKING 35° TROUGHING IDLER (LONG CENTER ROLL)

PART NUMBER	BELT WIDTH	A	C	E	G	H	J	WEIGHT
M1535-18	18	27	29	11 1/8	8 1/2	19 1/2	6 1/2	35
M1535-20	20	29	31	11 1/8	10 1/2	21 1/2	6 1/2	37
M1535-24	24	33	35	12 1/4	10 1/2	24 3/4	8 1/2	39
M1535-30	30	39	41	12 1/4	16 1/2	30 3/4	8 1/2	44
M1535-36	36	45	47	12 1/4	22 1/2	36 3/4	8 1/2	49
M1535-42	42	51	53	13 3/8	24 1/2	42	10 1/2	53

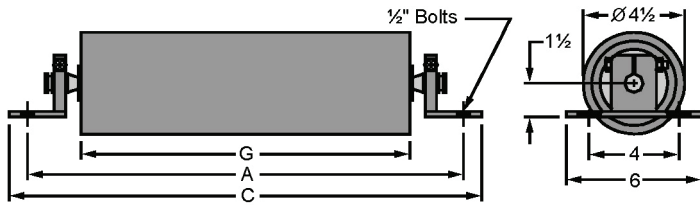

### ALTERNATE MOUNTING

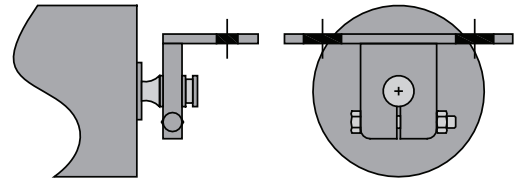

### M15R STANDARD RETURN IDLER (STEEL)

PART NUMBER	BELT WIDTH	A	C	G	WEIGHT
M15R-14	14	23	24 5/8	18 1/2	16
M15R-16	16	25	26 5/8	20 1/2	17
M15R-18	18	27	28 5/8	22 1/2	19
M15R-20	20	29	30 5/8	24 1/2	20
M15R-24	24	33	34 5/8	28 1/2	22
M15R-30	30	39	40 5/8	34 1/2	26
M15R-36	36	45	46 5/8	40 1/2	29
M15R-42	42	51	52 5/8	46 1/2	33

### MA15R NARROW BASE RETURN STYLE A (STEEL)

PART NUMBER	BELT WIDTH	A	C	G	WEIGHT
MA15R-14/16	14	20 3/4	22 3/8	16 1/2	15
	16				
MA15R-18/20	18	24 3/4	26 3/8	20 1/2	18
	20				
MA15R-24	24	28 3/4	30 3/8	24 1/2	20
MA15R-30	30	39	40 5/8	35 1/2	26
MA15R-36	36	42 1/2	44 1/8	38 1/2	28
MA15R-42	42	50 1/2	52 1/8	45 1/2	32

### MD15R RETURN IDLER STYLE D (STEEL)

PART NUMBER	BELT WIDTH	A	C	G	WEIGHT
MD15R-14	14	22	23 5/8	17 1/4	13
MD15R-16	16	24	25 5/8	19 1/4	14
MD15R-18	18	26	27 5/8	21 1/4	15
MD15R-20	20	28	29 5/8	23 1/4	16
MD15R-24	24	32	33 5/8	27 1/4	18
MD15R-30	30	38	39 5/8	33 1/4	21
MD15R-36	36	44	45 5/8	39 1/4	24
MD15R-42	42	50	51 5/8	45 1/4	26

### M15RM RUBBER DISC RETURN

PART NUMBER	BELT WIDTH	TL	RL	A	C	WEIGHT
M15RM-14	14	18 1/4	13	23	24 5/8	19
M15RM-16	16	20 1/4	15	25	26 5/8	20
M15RM-18	18	22 1/4	17	27	28 5/8	21
M15RM-20	20	24 1/4	19	29	30 5/8	22
M15RM-24	24	28 1/4	23	33	34 5/8	24
M15RM-30	30	34 1/4	29	39	40 5/8	27
M15RM-36	36	40 1/4	35	45	46 5/8	31
M15RM-42	42	46 1/4	41	51	52 5/8	34

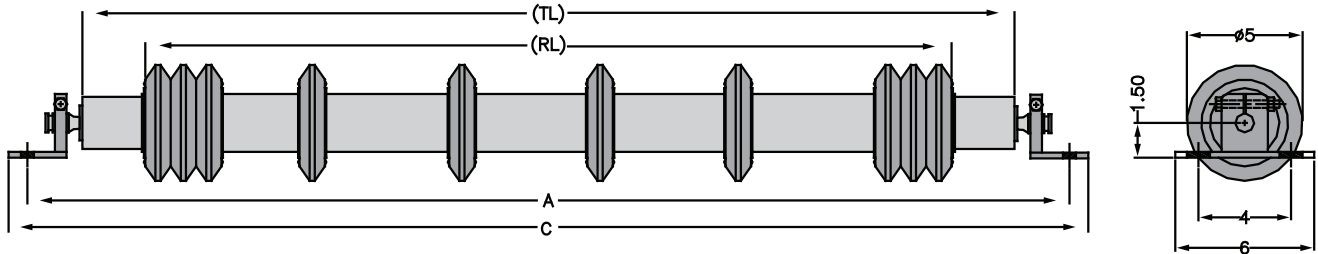

### M15FS FLAT ROLL

PART NUMBER	BELT WIDTH	A	C	G	WEIGHT
M15FS-14	14	23	24 5/8	18 1/2	15
M15FS-16	16	25	26 5/8	20 1/2	16
M15FS-18	18	27	28 5/8	22 1/2	17
M15FS-20	20	29	30 5/8	24 1/2	18
M15FS-22	22	31	32 5/8	26 1/2	19
M15FS-24	24	33	34 5/8	28 1/2	20
M15FS-26	26	35	36 5/8	30 1/2	21
M15FS-28	28	37	38 5/8	32 1/2	22
M15FS-30	30	39	40 5/8	34 1/2	23
M15FS-32	32	41	42 5/8	36 1/2	24
M15FS-34	34	43	44 5/8	38 1/2	25
M15FS-36	36	45	46 5/8	40 1/2	26
M15FS-38	38	47	48 5/8	42 1/2	27
M15FS-40	40	49	50 5/8	44 1/2	28
M15FS-42	42	51	52 5/8	46 1/2	29
M15FS-44	44	53	54 5/8	48 1/2	30
M15FS-46	46	55	56 5/8	50 1/2	31
M15FS-48	48	57	58 5/8	52 1/2	32

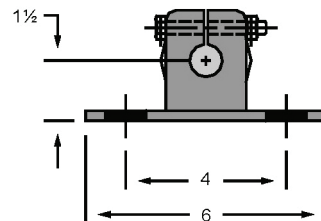
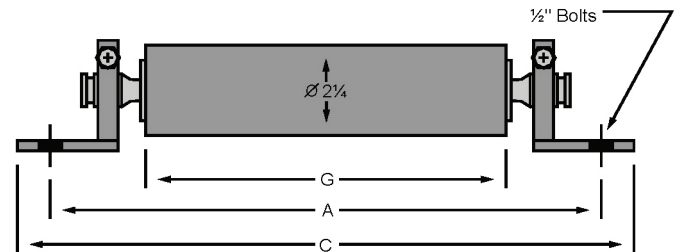

# MARCO® CHANNEL INSET LOW-HEADROOM IDLERS

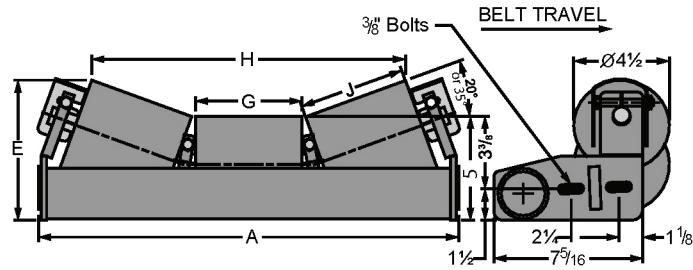

**MD15 EQUAL 20° LOW-HEADROOM TROUGHER STYLE D**

PART NUMBER	BELT WIDTH	A	E	G	H	J	WEIGHT
MD15-14	14	19 3/4	6 5/8	5	14 3/4	5	26
MD15-16	16	21 3/4	6 5/8	6 1/2	16 1/4	5	27
MD15-18	18	23 3/4	7 1/8	6 1/2	19	6 1/2	29
MD15-20	20	25 3/4	7 1/8	8 1/2	21 1/4	6 1/2	30
MD15-24	24	29 3/4	7 7/8	8 1/2	25	8 1/2	33
MD15-30	30	35 3/4	8 1/2	10 1/2	30 3/4	10 1/2	39
MD15-36	36	41 3/4	9 1/8	12 1/2	36 1/2	12 1/2	49
MD15-42	42	47 3/4	9 1/8	18 1/2	42 3/8	12 1/2	55

**MD1534 EQUAL 35° LOW-HEADROOM TROUGHER STYLE D**

PART NUMBER	BELT WIDTH	A	E	G	H	J	WEIGHT
MD1534-18	18	23 3/4	8 11/16	6 1/2	17 5/8	6 1/2	33
MD1534-20	20	25 3/4	8 11/16	8 1/2	19 5/8	6 1/2	34
MD1534-24	24	29 3/4	9 7/8	8 1/2	23	8 1/2	37
MD1534-30	30	35 3/4	10 15/16	10 1/2	28 1/4	10 1/2	42
MD1534-36	36	41 3/4	12 1/16	12 1/2	33 1/2	12 1/2	52
MD1534-42	42	47 3/4	13 5/16	14 1/2	38 3/4	14 1/2	58

## M15G - GUIDE ROLL

The M15G is designed to be bolted onto the end bracket of the troughing idler to help guide the belt. Weight = 4 1/2 lb each

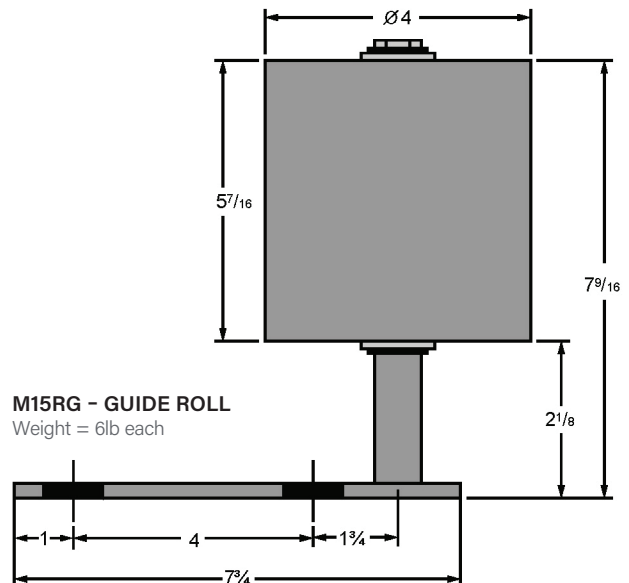
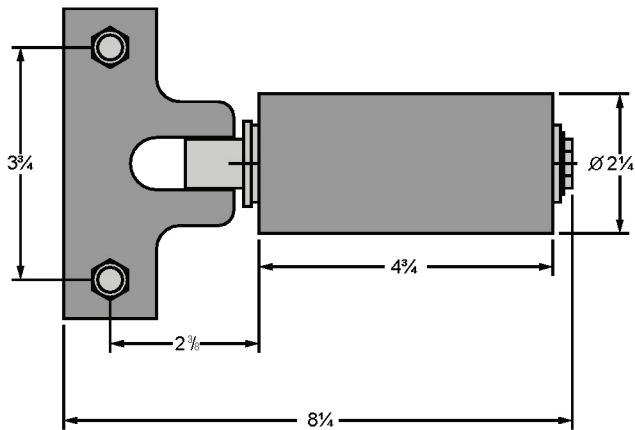

## M15RG - GUIDE ROLL

Weight = 6lb each

Marco® impact idlers use the same frame as Marco® steel roll idlers. Impact idlers use a 5" diameter rubber disc roll instead of 4½" diameter steel roll. The center roll height for the Marco® rubber disc roller is 7½" compared to 7¼" for the Marco® steel roll idlers.

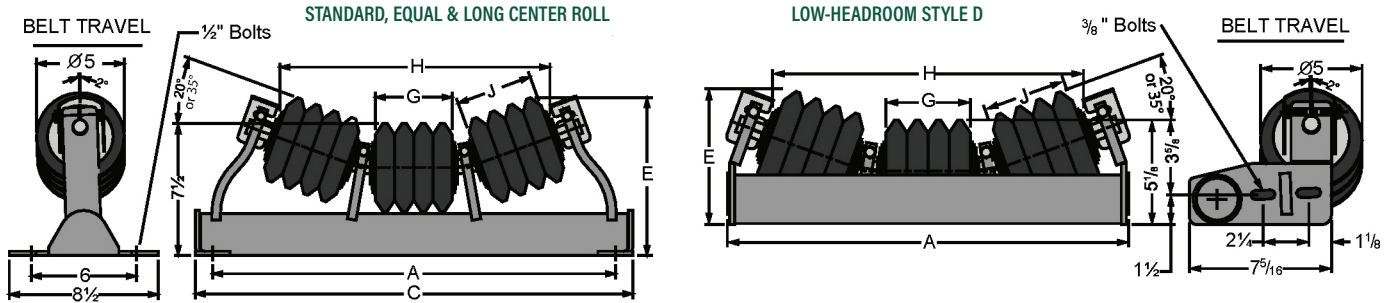

**M15M IMPACT STANDARD 20° TROUGHING IDLER**

PART NUMBER	BELT WIDTH	A	C	E	G	H	J	WEIGHT
M15M-14	14	23	25	9	5	14 7/8	5	33
M15M-16	16	25	27	9	6 1/2	16 5/8	5	36
M15M-18	18	27	29	9 1/2	6 1/2	19 1/4	6 1/2	39
M15M-20	20	29	31	9 1/2	8 1/2	21 1/4	6 1/2	42
M15M-24	24	33	35	10 1/4	8 1/2	25	8 1/2	49
M15M-30	30	39	41	10 7/8	10 1/2	30 3/4	10 1/2	58
M15M-36	36	45	47	11 5/8	12 1/2	36 1/2	12 1/2	67
M15M-42	42	51	53	11 5/8	18 1/2	42 1/2	12 1/2	76

**M1534M IMPACT EQUAL 35° TROUGHING IDLER**

PART NUMBER	BELT WIDTH	A	C	E	G	H	J	WEIGHT
M1534M-18	18	27	29	11 1/8	6 1/2	17 1/2	6 1/2	41
M1534M-20	20	29	31	11 1/8	8 1/2	19 1/2	6 1/2	44
M1534M-24	24	33	35	12 1/4	8 1/2	22 3/4	8 1/2	49
M1534M-30	30	39	41	13 3/8	10 1/2	28 1/4	10 1/2	59
M1534M-36	36	45	47	14 1/2	12 1/2	33 3/8	12 1/2	68
M1534M-42	42	51	53	15 5/8	14 1/2	38 1/2	14 1/2	77

**M1535M IMPACT PICKING 35° TROUGHING IDLER (LONG CENTER ROLL)**

PART NUMBER	BELT WIDTH	A	C	E	G	H	J	WEIGHT
M1535M-18	18	27	29	11 1/8	8 1/2	19 1/2	6 1/2	41
M1535M-20	20	29	31	11 1/8	10 1/2	21 1/2	6 1/2	44
M1535M-24	24	33	35	12 1/4	10 1/2	24 3/4	8 1/2	49
M1535M-30	30	39	41	13 3/8	16 1/2	30 3/4	8 1/2	59
M1535M-36	36	45	47	14 1/2	22 1/2	36 3/4	8 1/2	68
M1535M-42	42	51	53	15 5/8	24 1/2	42	10 1/2	77

**MD15M IMPACT EQUAL 20° LOW-HEADROOM TROUGHING IDLER STYLE D**

PART NUMBER	BELT WIDTH	A	E	G	H	J	WEIGHT
MD15M-14	14	19.75	6 5/8	5	14 3/4	5	24
MD15M-16	16	21.75	6 5/8	6 1/2	16 1/4	5	30
MD15M-18	18	23.75	7 1/8	6 1/2	19	6 1/2	33
MD15M-20	20	25.75	7 1/8	8 1/2	21 1/4	6 1/2	36
MD15M-24	24	29.75	7 7/8	8 1/2	25	8 1/2	40
MD15M-30	30	35.75	8 1/2	10 1/2	30 3/4	10 1/2	46
MD15M-36	36	41.75	9 1/8	12 1/2	36 1/2	12 1/2	52
MD15M-42	42	47.75	9 1/8	18 1/2	42 3/8	12 1/2	59

**MD1534M IMPACT EQUAL 35° LOW-HEADROOM TROUGHING IDLER STYLE D**

PART NUMBER	BELT WIDTH	A	E	G	H	J	WEIGHT
MD1534M-18	18	23.75	8 11/16	6 1/2	17 5/8	6 1/2	33
MD1534M-20	20	25.75	8 11/16	8 1/2	19 5/8	6 1/2	36
MD1534M-24	24	29.75	9 7/8	8 1/2	23	8 1/2	40
MD1534M-30	30	35.75	10 15/16	10 1/2	28 1/4	10 1/2	46
MD1534M-36	36	41.75	12 1/16	12 1/2	33 1/2	12 1/2	52
MD1534M-42	42	47.75	13 5/16	14 1/2	38 3/4	14 1/2	59

# MARCO® IDLER PARTS

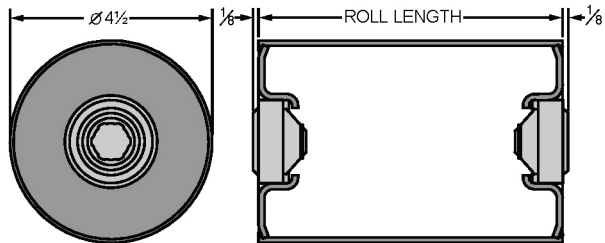

For CB504 replacement rolls to fit other frames, see our CB504 Roll flyer which can be downloaded from our website at [www.ppi-global.com](http://www.ppi-global.com).

## MARCO® ROLLS

PART NUMBER	ROLL LENGTH	WEIGHT
M3504-4.75	4 3/4	4.1
M3504-6.25	6 1/4	4.8
M3504-8.25	8 1/4	5.7
M3504-10.25	10 1/4	6.7
M3504-12.25	12 1/4	7.6
M3504-14.25	14 1/4	8.5
M3504-16.25	16 1/4	9.5
M3504-18.25	18 1/4	10.4
M3504-20.25	20 1/4	11.3
M3504-22.25	22 1/4	12.3
M3504-24.25	24 1/4	13.2
M3504-26.25	26 1/4	14.2
M3504-28.25	28 1/4	15.1
M3504-32.25	32 1/4	16.9
M3504-34.25	34 1/4	17.9
M3504-38.25	38 1/4	19.8
M3504-40.25	40 1/4	20.7
M3504-44.25	44 1/4	22.6
M3504-46.25	46 1/4	23.5

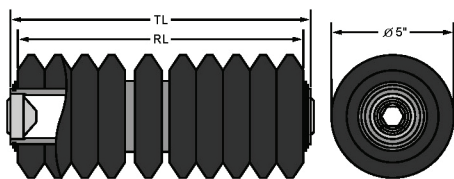

## MARCO® IMPACT ROLLS

PART NUMBER	RL	TL	WEIGHT
M15M-106-5	4 3/16	4 3/4	4.4
M15M-106-6	5 11/16	6 1/4	5.7
M15M-106-8	7 11/16	8 1/4	7.7
M15M-106-10	9 11/16	10 1/4	9.8
M15M-106-12	11 11/16	12 1/4	11.2
M15M-106-14	13 11/16	14 1/4	13.2
M15M-106-16	15 11/16	16 1/4	15.3
M15M-106-18	17 11/16	18 1/4	17.4
M15M-106-20	19 11/16	20 1/4	18.8
M15M-106-22	21 11/16	22 1/4	20.8
M15M-106-24	23 11/16	24 1/4	22.9

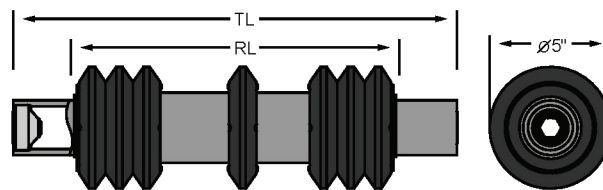

## MARCO® RUBBER DISC RETURN ROLLS

PART NUMBER	RL	TL	WEIGHT
M15RM-106-18	13	18 1/4	14.5
M15RM-106-20	15	20 1/4	15.7
M15RM-106-22	17	22 1/4	16.8
M15RM-106-24	19	24 1/4	18.5
M15RM-106-28	24	28 1/4	20.8
M15RM-106-34	29	34 1/4	24.8
M15RM-106-40	35	40 1/4	28.7
M15RM-106-46	41	46 1/4	32.7

1½" MOUNTING BRACKET

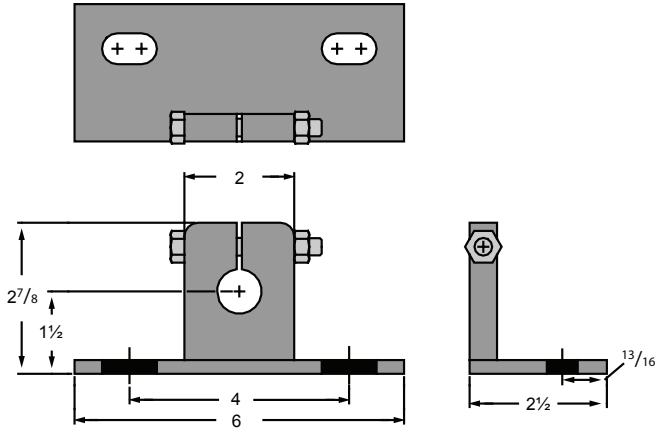

Part # M15R-101-1

Weight 1.7 lb

MARCO® END STUB SHAFT - TYPE 1

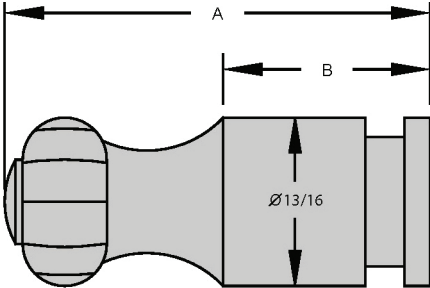

MARCO® CENTER STUB SHAFT - TYPE 2

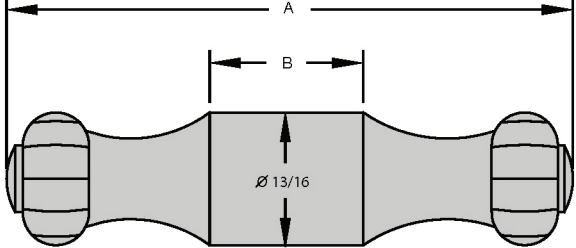

MARCO® STUB SHAFTS

PART NUMBER	DESCRIPTION	TYPE	A	B	WEIGHT
40451	End Stub Shaft	1	2 1/2	1 1/2	0.30
40456	15 Series	2	2 5/8	5/8	0.26
40458	1534 & 1535 Series	2	3	1	0.34



**PPI**<sup>®</sup>

**[WWW.PPI-GLOBAL.COM](http://WWW.PPI-GLOBAL.COM) | [SALES@PPI-GLOBAL.COM](mailto:SALES@PPI-GLOBAL.COM)**

Product shown are for illustrative purposes only and may display optional accessories or components. Please contact your sales representative for more information on product specifications.  
PPI respectively reserves the right to make changes in engineering, design and specifications; add improvements; or discontinue manufacturing at any time without notice obligation.  
PPI and its respective logo is a trademark of Precision, Inc. in the US and or other countries.