

# IMPACT IDLER SELECTION DATA SHEET

Once the information from this data sheet has been reviewed, PPI's engineers will determine the best impact system for your application.

MATERIAL TYPE \_\_\_\_\_  
 MATERIAL DENSITY (LB/FT<sup>3</sup>) \_\_\_\_\_  
 LARGEST LUMP SIZE \_\_\_\_\_  
 (DETAIL A) DROP HEIGHT \_\_\_\_\_  
 (DETAIL B) DH1-DH2-DH3 \_\_\_\_\_  
 ANGLE \_\_\_\_\_  
 BELT WIDTH \_\_\_\_\_  
 TROUGH ANGLE \_\_\_\_\_  
 ROLL DIAMETER \_\_\_\_\_  
 BED LENGTH \_\_\_\_\_  
 SKIRT WIDTH \_\_\_\_\_  
 CEMA SERIES \_\_\_\_\_

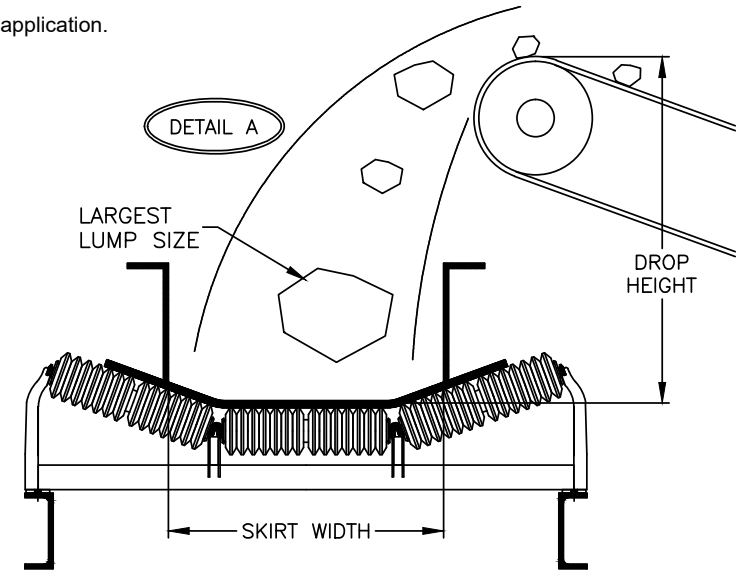
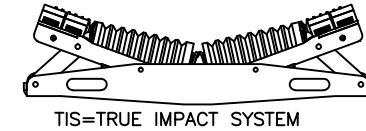
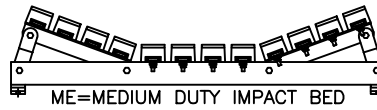
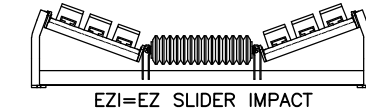
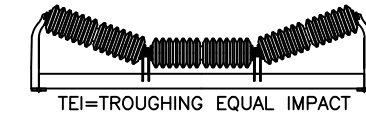

COMPANY NAME \_\_\_\_\_  
 LOCATION \_\_\_\_\_  
 CONTACT NAME \_\_\_\_\_  
 PHONE \_\_\_\_\_  
 E-MAIL \_\_\_\_\_  
 DATE \_\_\_\_\_

NOTES \_\_\_\_\_  
 \_\_\_\_\_

